

Summer School on
Empirical Processes

University of Aarhus, 9-20 August 1999

Principal Course on

**EMPIRICAL AND PARTIAL - SUM PROCESSES
REVISITED AS RANDOM MEASURE PROCESSES**

by Peter Gaenssler (Munich)

BASED ON THE PRESENT

Lecture Notes

by

Peter Gaenssler and Daniel Rost

Mathematical Institute
University of Munich
Theresienstrasse 39
D-80333 Munich
Germany

Preface

The interest of the first author of the present Lecture Notes in empirical process theory arose after having studied Ron Pyke's beautiful survey [Py72] on Empirical Processes where Ron underlines his view that "the development of empirical processes provides an excellent illustration of the interplay between statistics and probability and of increased sophistication of mathematical techniques which have been introduced into these disciplines in recent years." Since then the theory of empirical processes has grown in an enormous way initiated by Dudley's [Du78] fundamental paper and culminating in his book [Du99]. Also the books of Shorack-Wellner [Sh86] and van der Vaart-Wellner [Va96] together with Pollard [Po84],[Po90] and the overview given by Giné [Gi96] confirm Pyke's early view in a very impressive way.

In view of the large literature on empirical processes which have appeared in recent years, the present Lecture Notes will only cover a small amount of the subject. Our approach in revisiting Empirical and Partial-Sum Processes as so-called Random Measure Processes had its origin in the papers by Pyke [Py84] and Ossiander-Pyke [Os85].

We hope to raise with our presentation further interest in empirical process theory.

Munich, July 1999

Peter Gaenssler and Daniel Rost

Contents

1 Introduction	1
1.1 The uniform empirical process α_n	1
1.2 The classical partial-sum process ζ_n	4
1.3 The multivariate case	9
1.4 α_n and ζ_n as set-indexed processes	10
1.5 A first glance at Glivenko-Cantelli convergence and Vapnik-Chervonenkis classes of sets	11
2 Empirical Measures in general sample spaces	16
2.1 Empirical Discrepancies, Glivenko-Cantelli convergence and some consequences in statistics	16
2.2 Functional Central Limit Theorems for set-indexed empirical and partial-sum processes, respectively	18
2.3 Weak convergence (\mathcal{L} -convergence) in the sense of Hoffmann-Jørgensen	20
3 Random Measures Processes (RMP's)	30
3.1 Empirical Processes, partial-sum processes and smoothed empirical processes, respectively, considered as special cases of RMP's	30
3.2 Further Examples	31
4 Metric Entropy and Vapnik-Chervonenkis classes	39
4.1 Packing and covering numbers; Metric Entropy	39
4.2 Vapnik-Chervonenkis classes in arbitrary sample spaces $X = (X, \mathcal{X})$	40
4.3 Vapnik-Chervonenkis graph classes of \mathcal{X} -measurable functions $f : X \rightarrow \mathbb{R}$	43

5	Some Fundamental Inequalities	55
5.1	Symmetrization Inequality	55
5.2	Maximal Inequality for Rademacher Averages	57
5.3	Hoffmann-Jørgensen Inequality	60
6	Uniform Laws of Large Numbers (ULLN)	62
6.1	A ULLN for RMP's	62
6.2	ULLN's for partial-sum processes with either fixed or random locations	66
6.3	ULLN's for empirical processes	68
6.4	ULLN's for smoothed empirical processes	69
7	Functional Central Limit Theorems (FCLT)	79
7.1	A FCLT for RMP's	79
7.2	FCLT's for partial-sum processes with either fixed or random locations	85
7.3	FCLT's for empirical processes	91
7.4	FCLT's for smoothed empirical processes	93
7.5	A uniform FCLT for the unbiased smoothed empirical process ...	95
	List of Symbols	104
	References	107

Summary

In a general framework of so-called Random Measure Processes (RMP's) we present uniform laws of large numbers (ULLN) and functional central limit theorems (FCLT) for RMP's yielding known and also new results for empirical processes and for so-called smoothed empirical processes based on data in general sample spaces. At the same time one obtains results for Partial-sum processes with either fixed or random locations. Proofs are based on tools from modern empirical process theory as presented e.g. in [Va96].

Our presentation will be also guided by showing up some aspects of the development of empirical process theory from its classical origin up to its present generality which now offers a wide variety of applications in statistics as demonstrated e.g. in Part 3 of [Va96].

1 Introduction

1.1 The uniform empirical process α_n

Two important processes in probability and statistics are the *empirical* and *partial-sum process*.

Let $\eta_j, j \in \mathbb{N}$, be independent identically distributed (iid) random variables (rv's) with law $\mathcal{L}\{\eta_j\} = U[0, 1]$ (the uniform distribution on $I = [0, 1]$), defined on a basic probability space (p-space) $(\Omega, \mathcal{A}, \mathbb{P})$, i.e. $\eta_j : \Omega \rightarrow I$ with $\mathbb{P}(\eta_j \leq t) = F(t) := t \quad \forall t \in I$.

Let F_n be the empirical distribution function (edf) based on η_1, \dots, η_n , i.e.

$$F_n(t) := n^{-1} \sum_{j \leq n} 1_{[0, t]}(\eta_j). \quad t \in I;$$

to indicate that F_n is random, i.e. depending on $\omega \in \Omega$, we also write instead of $F_n(t)$

$$F_n(t, \omega) = n^{-1} \sum_{j \leq n} 1_{[0, t]}(\eta_j(\omega)).$$

(1_A denotes the indicator function of a set A .)

THEN:

$\forall t \in I \quad \mathbb{E}(F_n(t)) = F(t)$ (i.e. $F_n(t)$ is an unbiased estimator for $F(t)$)

$\forall t \in I$ by the classical central limit theorem (CLT)

$$\alpha_n(t) := n^{1/2}(F_n(t) - F(t)) \xrightarrow{\mathcal{L}} \mathcal{N}(0, F(t)(1 - F(t)))$$

(where $\xrightarrow{\mathcal{L}}$ denotes convergence in law), and by the strong law of large numbers (LLN)

$\forall t \in I \quad F_n(t) \rightarrow F(t) \quad \mathbb{P}$ -almost surely (a.s.)

(i.e. $(F_n(t))_{n \in \mathbb{N}}$ is a strongly consistent sequence of estimators for $F(t)$);
 moreover, by the *GLIVENKO-CANTELLI THEOREM*,

$$\sup_{t \in I} |F_n(t) - F(t)| \longrightarrow 0 \quad \mathbb{P} - a.s.$$

(Note that $\sup_{t \in I} |F_n(t) - F(t)|$ is measurable since it remains unchanged when replacing I by the countable index set $I \cap \mathbb{Q}$.)

FUNCTIONAL VIEWPOINT

The stochastic process $\alpha_n = (\alpha_n(t))_{t \in I}$ is called **UNIFORM EMPIRICAL PROCESS** (of sample size n). Its sample paths

$$\alpha_n(\omega) = \left(n^{1/2} (F_n(t, \omega) - F(t)) \right)_{t \in I}$$

are contained in the space $D := \{x \in \mathbb{R}^I : x \text{ satisfies (i) - (iii)}\}$:

- (i) $\forall t \in [0, 1) \exists x(t+0) := \lim_{s \searrow t} x(s)$
- (ii) $\forall t \in (0, 1] \exists x(t-0) := \lim_{s \nearrow t} x(s)$
- (iii) $\forall t \in [0, 1) x(t) = x(t+0)$.

Since $\sup_{t \in I} |x(t)| < \infty \quad \forall x \in D$, it is tempting to endow the space D with the sup-metric ρ , i.e. with

$$\rho(x_1, x_2) := \sup_{t \in I} |x_1(t) - x_2(t)|, \quad x_1, x_2 \in D,$$

which is usually considered in the space $C \equiv C(I)$ of continuous functions on I .

Note that (C, ρ) is a closed separable subspace of (D, ρ) being also complete (cf. [Bi68], p.220).

In contrast, (D, ρ) is not separable and $\alpha_n : \Omega \rightarrow D$ is not $\mathcal{A}, \mathcal{B}(\rho)$ -measurable if D is equipped with the σ -field $\mathcal{B}(\rho)$ of Borel sets w.r.t. the ρ -topology; cf. [Bi68], p.152.

At this place there were two ways to overcome this difficulty (cf. [Bi68]):

- (i) Skorokhod's metric s being weaker than ρ which makes $\alpha_n : \Omega \rightarrow D$ $\mathcal{A}, \mathcal{B}(s)$ -measurable ($\mathcal{B}(s) :=$ Borel σ -field in (D, s))
- (ii) [Du66] (cf. also [Wi68] and [Gae83]):
 Consider instead of $\mathcal{B}(\rho)$ the smaller σ -field $\mathcal{B}_b(\rho)$ generated by the open ρ -balls in (D, ρ) ; then again $\alpha_n : \Omega \rightarrow D$ becomes $\mathcal{A}, \mathcal{B}_b(\rho)$ -measurable, since $\mathcal{B}_b(\rho) = \sigma(\{\pi_t : t \in I\})$ (\equiv σ -field generated by the projections $\pi_t : D \rightarrow \mathbb{R}, \pi_t(x) := x(t)$).

1.1.1 Remarks.

Let $\mathcal{B}(C, \rho)$ be the Borel σ -field in (C, ρ) and $\mathcal{B}_b(C, \rho)$ be the σ -field generated by the open ρ -balls in (C, ρ) ; then $\mathcal{B}(C, \rho) = \mathcal{B}_b(C, \rho) = C \cap \mathcal{B}_b(\rho)$, whence

$$(1.1.2) \quad \mathcal{B}(C, \rho) = \sigma(\{rest_C \pi_t : t \in I\});$$

furthermore $C \in \mathcal{B}_b(\rho)$ and (cf. [Bi68], Th. 14.5) $\mathcal{B}(s) = \sigma(\{\pi_t : t \in I\})$, whence

$$(1.1.3) \quad \mathcal{B}(s) = \mathcal{B}_b(\rho).$$

In the following let $B = (B(t))_{t \in I}$ be the Wiener process (Brownian Motion) with parameter set $T = I$, and let $B^\circ = (B^\circ(t))_{t \in I}$ be the Brownian Bridge ($B^\circ(t) := B(t) - tB(1)$); both processes are mean-zero Gaussian processes with sample paths in C , whose covariance structure is given by

$$(1.1.4) \quad \text{cov}(B(t_1), B(t_2)) = t_1 \wedge t_2, \quad t_1, t_2 \in I, \text{ and}$$

$$(1.1.5) \quad \text{cov}(B^\circ(t_1), B^\circ(t_2)) = t_1 \wedge t_2 - t_1 \cdot t_2, \quad t_1, t_2 \in I,$$

respectively. Both processes can be viewed as random elements (re) in $(C, \mathcal{B}(C, \rho))$ or as random elements in $(D, \mathcal{B}_b(\rho))$ with $\mathcal{L}\{B\}(C) = 1$ and $\mathcal{L}\{B^\circ\}(C) = 1$ respectively.

HERE: Given a measurable space (X, \mathcal{X}) , we say that η is a re in $(X, \mathcal{X}) : \iff \exists$ p-space $(\Omega, \mathcal{A}, \mathbb{P})$ s.t. $\eta : \Omega \rightarrow X$ is \mathcal{A}, \mathcal{X} -measurable.

The following prospect is taken from [Do49]:

“Noticing that, by the multivariate CLT, the finite-dimensional distributions (fidis) of α_n are asymptotically (as $n \rightarrow \infty$) the same as those of B° , we may assume—until a contradiction frustrates our devotion to heuristic reasoning—that in calculating asymptotic distributional results for the α_n -process one may simply replace the α_n 's by B° .”

This prospect was justified by the following Functional Central Limit Theorem (FCLT):

1.1.6 THEOREM ([Don51],[Don52],[Pro56]).

$$\alpha_n \xrightarrow{\mathcal{L}} B^\circ \quad \text{in } (D, s),$$

$$\text{i.e. } \lim_{n \rightarrow \infty} \mathbb{E}(f(\alpha_n)) = \mathbb{E}(f(B^\circ)) \quad \forall f \in C^b(D),$$

where $C^b(D) := \{f : D \rightarrow \mathbb{R} : f \text{ s-continuous and bounded}\}$.

Note also that $\mathcal{L}\{B^\circ\}(C) = 1$ in view of 1.1.7 below.

Taking instead of s the sup-metric ρ one gets

1.1.6' THEOREM.

$$\alpha_n \xrightarrow{\mathcal{L}_b} B^\circ \quad \text{in } (D, \rho),$$

$$\text{i.e. } \lim_{n \rightarrow \infty} \mathbb{E}(f(\alpha_n)) = \mathbb{E}(f(B^\circ)) \quad \forall f \in C_b^b(D),$$

where $C_b^b(D) := \{f : D \rightarrow \mathbb{R} : f \text{ } \rho\text{-continuous, } \mathcal{B}_b(\rho)\text{-measurable and bounded}\}$.

In fact 1.1.6 and 1.1.6' are equivalent according to the following lemma. For this, let $\eta_n, n \geq 0$, be a sequence of re's in $(D, \mathcal{B}_b(\rho)) \stackrel{(1.1.3)}{=} (D, \mathcal{B}(s))$, and

$$\eta_n \xrightarrow{\mathcal{L}} \eta_0 : \iff \lim_{n \rightarrow \infty} \mathbb{E}(f(\alpha_n)) = \mathbb{E}(f(B^\circ)) \quad \forall f \in C^b(D), \text{ and}$$

$$\eta_n \xrightarrow{\mathcal{L}_b} \eta_0 : \iff \lim_{n \rightarrow \infty} \mathbb{E}(f(\alpha_n)) = \mathbb{E}(f(B^\circ)) \quad \forall f \in C_b^b(D),$$

respectively.

(Note that $\mathcal{L}\{\eta_n\}, n \geq 0$, is well defined on $\mathcal{B}_b(\rho) = \mathcal{B}(s)$ and that $\lim_{n \rightarrow \infty} \mathbb{E}(f(\alpha_n)) = \mathbb{E}(f(B^\circ)) \iff \lim_{n \rightarrow \infty} \int_D f d\mathcal{L}\{\eta_n\} = \int_D f d\mathcal{L}\{\eta_0\}$.)

1.1.7 Lemma ([Gae83], Lemma 18.p.93).

$$\eta_n \xrightarrow{\mathcal{L}} \eta_0 \quad \text{and} \quad \mathcal{L}\{\eta_0\}(C) = 1 \implies \eta_n \xrightarrow{\mathcal{L}_b} \eta_0;$$

conversely, $\eta_n \xrightarrow{\mathcal{L}_b} \eta_0 \implies \eta_n \xrightarrow{\mathcal{L}} \eta_0$.

The same situation is met in section 1.2 in connection with the classical partial-sum process.

As we shall see in section 2.3 the concept of weak convergence (\mathcal{L} - convergence) can be generalized in such a way that the approximating sequence $(\eta_n)_{n \in \mathbb{N}}$ is not assumed to consist of re's, i.e. arbitrary η_n 's will be allowed; measurability is solely assumed for η_0 to which η_n converges weakly.

1.2 The classical partial-sum process ζ_n

Let $\xi_j, j \in \mathbb{N}$, be iid rv's defined on a basic p-space $(\Omega, \mathcal{A}, \mathbb{P})$ with $\mathbb{E}(\xi_j) = 0$ and $\mathbb{E}(\xi_j^2) = 1$. Let

$$\zeta_n(t) := n^{-1/2} \sum_{\{j: j/n \leq t\}} \xi_j, \quad t \in I;$$

THEN:

$$\begin{aligned} \mathbb{E}(\zeta_n(t)) &= 0 \quad \text{and} \quad \zeta_n(t) \xrightarrow{\mathcal{L}} \mathcal{N}(0, t) \quad \forall t \in I \\ \text{and} \quad \text{cov}(\zeta_n(t_1), \zeta_n(t_2)) &= t_1 \wedge t_2, \quad t_1, t_2 \in I. \end{aligned}$$

FUNCTIONAL VIEWPOINT

The stochastic process $\zeta_n = (\zeta_n(t))_{t \in I}$ is the CLASSICAL (standardized) PARTIAL-SUM PROCESS (of sample size n).

(with $\langle a \rangle := \max\{z \in \mathbb{Z} : z \leq a\}, a \in \mathbb{R}$, $\zeta_n(t)$ can also be written as $\zeta_n(t) = n^{-1/2} \sum_{j=1}^{\langle nt \rangle} \xi_j$.)

Its sample paths $\zeta_n(\omega) = (n^{-1/2} \sum_{j \leq \langle nt \rangle} \xi_j(\omega))_{t \in I}$ are contained in D . ζ_n can be viewed as re in $(D, \mathcal{B}_b(\rho)) = (D, \mathcal{B}(s))$ and the FCLT for ζ_n is also due to Donsker:

1.2.1 THEOREM.

$$\begin{aligned} \zeta_n &\xrightarrow{\mathcal{L}} B \quad \text{in } (D, s) \quad \text{or, equivalently,} \\ \zeta_n &\xrightarrow{\mathcal{L}_b} B \quad \text{in } (D, \rho). \end{aligned}$$

Theorem 1.2.1 and 1.1.6 are special cases of FCLT's to be considered in section 7.

Nevertheless we want to present here proofs in a form due to Franz Strobl [St90] yielding some indications when dealing later with more general processes.

The following proofs are based on the characterization theorem of \mathcal{L} -convergence (CTL-C) presented in section 2.3 (here with parameter space $T = I$ and metric $d(t_1, t_2) := |t_1 - t_2|, t_1, t_2 \in I$).

PROOF OF THEOREM 1.1.6. According to CTL-C we have to show (i) and (ii), where

(i) $\alpha_n \xrightarrow[\text{fidi}]{\mathcal{L}} B^\circ$, i.e. weak convergence of the finite-dimensional distributions (fidis) of α_n to the corresponding fidis of B° .

(ii) $\lim_{\delta \rightarrow 0} \limsup_{n \rightarrow \infty} \mathbb{P}^*(w_{\alpha_n}(\delta) > \varepsilon) = 0 \quad \forall \varepsilon > 0$,
where $\mathbb{P}^*(A) := \inf\{\mathbb{P}(B) : A \subset B, B \in \mathcal{A}\} \quad \forall A \subset \Omega$, and where
 $w_{\alpha_n}(\delta) := \sup_{\substack{t, t' \in I \\ |t-t'| \leq \delta}} |\alpha_n(t) - \alpha_n(t')| \quad \forall \delta > 0$.

The proof of (i) follows by the multivariate CLT and can be found in standard textbooks (c.f. e.g. [Gae77], 12.2.1).

PROOF OF (ii). Let $\varepsilon > 0$ be arbitrary; w.l.o.g. let

$$(1) \quad \delta \in \mathbb{Q}, \quad 0 < \delta < \frac{1}{4} \quad \text{and} \quad n \geq 9216 \cdot \delta^{-3}.$$

STEP 1: "We are going back to a grid of span δ " in the parameter-space $T = I$; then

$$\{w_{\alpha_n}(\delta) > \varepsilon\} = \{\exists t_i \in I, i = 1, 2, \text{ s.t. } 0 < t_2 - t_1 \leq \delta \quad \text{and} \quad |\alpha_n(t_1) - \alpha_n(t_2)| > \varepsilon\}.$$

Now, to each gridpoint t_i we associate a $k_i \in \mathbb{Z}_+$ s.t. $k_i \delta < t_i \leq (k_i + 1)\delta$, where $k_2 - k_1 \leq 1$ if $t_2 - t_1 \leq \delta$. Then

$$\{w_{\alpha_n}(\delta) > \varepsilon\} = \bigcup_{\substack{k \in \mathbb{Z}_+ \\ k < \frac{1}{\delta}}} \{\exists t \in (k\delta, (k+1)\delta] \cap I : |\alpha_n(t) - \alpha_n(k\delta)| > \varepsilon/3\},$$

whence

$$\begin{aligned} \mathbb{P}^*(w_{\alpha_n}(\delta) > \varepsilon) &\leq \sum_{\substack{k \in \mathbb{Z}_+ \\ k < \frac{1}{\delta}}} \mathbb{P}^* \left(\sup_{t \in (k\delta, (k+1)\delta] \cap I} |\alpha_n(t) - \alpha_n(k\delta)| > \varepsilon/3 \right) \\ &= \sum_{\substack{k \in \mathbb{Z}_+ \\ k < \frac{1}{\delta}}} \mathbb{P} \left(\sup_{t \in (k\delta, (k+1)\delta] \cap I \cap \mathbb{Q}} \left| n^{-1/2} \sum_{i \leq n} (1_{(k\delta, t]}(\eta_i) - (t - k\delta)) \right| > \varepsilon/3 \right) \\ &\leq \left(\frac{1}{\delta} + 1 \right) \mathbb{P} \left(\sup_{t \in (0, \delta] \cap \mathbb{Q}} |\alpha_n(t)| > \varepsilon/3 \right), \end{aligned}$$

i.e. we have

$$(2) \quad \mathbb{P}^*(w_{\alpha_n}(\delta) > \varepsilon) \leq \left(\frac{1}{\delta} + 1 \right) \mathbb{P} \left(\sup_{t \in (0, \delta] \cap \mathbb{Q}} |\alpha_n(t)| > \varepsilon/3 \right).$$

Now, let $T_m \subset (0, \delta] \cap \mathbb{Q}$ be s.t. $|T_m| = m \quad \forall m \in \mathbb{N}$, and $T_m \nearrow (0, \delta] \cap \mathbb{Q}$ as $m \rightarrow \infty$; then we have

$$(3) \quad \mathbb{P} \left(\sup_{t \in (0, \delta] \cap \mathbb{Q}} |\alpha_n(t)| > \varepsilon/3 \right) = \lim_{m \rightarrow \infty} \mathbb{P} \left(\sup_{t \in T_m} |\alpha_n(t)| > \varepsilon/3 \right).$$

STEP 2: Let $m \in \mathbb{N}$ be arbitrary but fixed, $T_m = \{t_1, \dots, t_m\}$, $0 =: t_0 < t_1 < \dots < t_m \leq \delta$, and $A := \{\sup_{t \in T_m} |\alpha_n(t)| > \varepsilon\}$; then $A \subset B + \sum_{k \leq m} A_k^+ + \sum_{k \leq m} A_k^-$ with

$$B := \left\{ \sum_{i \leq n} 1_{[0, \delta]}(\eta_i) > n/2 \right\},$$

$$A_k^+ := \left\{ \alpha_n(t_j) \leq \varepsilon/3, j = 1, \dots, k-1, \alpha_n(t_k) > \varepsilon/3, \sum_{i \leq n} 1_{[0, t_k]}(\eta_i) \leq n/2 \right\},$$

$$A_k^- := \left\{ \alpha_n(t_j) \geq -\varepsilon/3, j = 1, \dots, k-1, \alpha_n(t_k) < -\varepsilon/3, \sum_{i \leq n} 1_{[0, t_k]}(\eta_i) \leq n/2 \right\}, \quad 1 \leq k \leq m;$$

now, we are going to show

$$(4) \quad \mathbb{P}(A_k^{+/-}) \leq 4 \mathbb{P}\left(A_k^{+/-} \cap \left\{ \alpha_n(2\delta) \geq/\leq \alpha_n(t_k) \frac{1-2\delta}{1-t_k} \right\}\right) \quad \forall 1 \leq k \leq m :$$

Let $k \in \{1, \dots, m\}$ be arbitrary but fixed and

$$R := \left\{ \underline{r} = (r_1, \dots, r_k) : r_i \in \mathbb{Z}_+, n^{-1/2}(r_1 + \dots + r_j - nt_j) \leq \varepsilon/3 \quad \forall 1 \leq j \leq k-1, \right. \\ \left. n^{-1/2}(r_1 + \dots + r_k - nt_k) > \varepsilon/3, r_1 + \dots + r_k \leq n/2 \right\};$$

then

$$\begin{aligned} & \mathbb{P}\left(A_k^+ \cap \left\{ \alpha_n(2\delta) \geq \alpha_n(t_k) \frac{1-2\delta}{1-t_k} \right\}\right) \\ &= \mathbb{P}\left(n^{-1/2} \left(\sum_{i \leq n} 1_{[0, t_j]}(\eta_i) - nt_j \right) \leq \varepsilon/3, j = 1, \dots, k-1, n^{-1/2} \left(\sum_{i \leq n} 1_{[0, t_k]}(\eta_i) - nt_k \right) > \varepsilon/3, \right. \\ & \quad \left. \sum_{i \leq n} 1_{[0, t_k]}(\eta_i) \leq n/2, \sum_{i \leq n} 1_{(t_k, 2\delta]}(\eta_i) \geq \left(\sum_{i \leq n} 1_{[0, t_k]}(\eta_i) - nt_k \right) \frac{1-2\delta}{1-t_k} + 2n\delta - \sum_{i \leq n} 1_{[0, t_k]}(\eta_i) \right) \\ &= \sum_{\substack{\underline{r} \in R \\ r := r_1 + \dots + r_k}} \mathbb{P}\left(\sum_{i \leq n} 1_{(t_{j-1}, t_j]}(\eta_i) = r_j, j = 1, \dots, k, \sum_{i \leq n} 1_{(t_k, 2\delta]}(\eta_i) \geq (n-r) \frac{2\delta - t_k}{1-t_k}\right) \\ &= \sum_{\substack{\underline{r} \in R \\ r := r_1 + \dots + r_k}} \sum_{s \in \left[(n-r) \frac{2\delta - t_k}{1-t_k}, n-r \right] \cap \mathbb{Z}_+} \binom{n}{r_1, \dots, r_k, s, n-r-s} \cdot (t_1 - t_0)^{r_1} \dots (t_k - t_{k-1})^{r_k} \cdot (2\delta - t_k)^s (1-2\delta)^{n-r-s} \\ &= \sum_{\underline{r}} \sum_s \binom{n}{r_1, \dots, r_k, n-r} \frac{(n-r)!}{s!(n-r-s)!} \cdot (t_1 - t_0)^{r_1} \dots (t_k - t_{k-1})^{r_k} (1-t_k)^{n-r} \frac{(2\delta - t_k)^s (1-2\delta)^{n-r-s}}{(1-t_k)^{n-r}} \\ &= \sum_{\underline{r}} \mathbb{P}\left(\sum_{i \leq n} 1_{(t_{j-1}, t_j]}(\eta_i) = r_j, j = 1, \dots, k\right) \cdot \sum_s \mathbb{P}\left(\sum_{i \leq n-r} 1_{[0, \frac{2\delta - t_k}{1-t_k}]}(\eta_i) = s\right); \end{aligned}$$

since $\sigma^2 := \text{Var}(1_{[0, \frac{2\delta-t_k}{1-t_k}]}(\eta_1)) = \frac{2\delta-t_k}{1-t_k} \cdot \frac{1-2\delta}{1-t_k} \stackrel{(1)}{\geq} \delta/2$, it follows that

$$\begin{aligned} \sum_s \mathbb{P}\left(\sum_{i \leq n-r} 1_{[0, \frac{2\delta-t_k}{1-t_k}]}(\eta_i) = s\right) &= \mathbb{P}\left(\sum_{i \leq n-r} 1_{[0, \frac{2\delta-t_k}{1-t_k}]}(\eta_i) \geq (n-r) \frac{2\delta-t_k}{1-t_k}\right) \\ &= \mathbb{P}\left(\sum_{i \leq n-r} 1_{[0, \frac{2\delta-t_k}{1-t_k}]}(\eta_i) - (n-r) \frac{2\delta-t_k}{1-t_k} \geq 0\right) \\ &\stackrel{\text{(BERRY-ESSÉEN)}}{\geq} \frac{1}{2} - \frac{6}{\sqrt{n-r}\sigma^3} \mathbb{E}\left(\left|1_{[0, \frac{2\delta-t_k}{1-t_k}]}(\eta_1) - \frac{2\delta-t_k}{1-t_k}\right|^3\right) \\ &\stackrel{(r \leq n/2)}{\geq} \frac{1}{2} - \frac{6}{\sqrt{n/2}(\delta/2)^{3/2}} \stackrel{(1)}{\geq} \frac{1}{4}; \end{aligned}$$

therefore

$$\begin{aligned} &\mathbb{P}\left(A_k^+ \cap \left\{\alpha_n(2\delta) \geq \alpha_n(t_k) \frac{1-2\delta}{1-t_k}\right\}\right) \geq \\ &\frac{1}{4} \mathbb{P}\left(\alpha_n(t_j) \leq \varepsilon/3, j = 1, \dots, k-1, \alpha_n(t_k) > \varepsilon/3, \sum_{i \leq n} 1_{[0, t_k]}(\eta_i) \leq n/2\right), \end{aligned}$$

which proves (4) for A_k^+ . Analogously one shows that

$$\mathbb{P}(A_k^-) \leq 4 \mathbb{P}\left(A_k^- \cap \left\{\alpha_n(2\delta) \leq \alpha_n(t_k) \frac{1-2\delta}{1-t_k}\right\}\right).$$

STEP 3: According to STEP 2 we have for any fixed $m \in \mathbb{N}$ with $T_m = \{t_1, \dots, t_m\}$ and $0 =: t_0 < t_1 < \dots < t_m \leq \delta$ that

$$\begin{aligned} &\mathbb{P}\left(\sup_{t \in T_m} |\alpha_n(t)| > \varepsilon\right) \leq \\ &\mathbb{P}\left(\sum_{i \leq n} 1_{[0, \delta]}(\eta_i) > \frac{n}{2}\right) + 4 \sum_{k \leq m} \mathbb{P}\left(A_k^+ \cap \left\{\alpha_n(2\delta) \geq \alpha_n(t_k) \frac{1-2\delta}{1-t_k}\right\}\right) + \\ &4 \sum_{k \leq m} \mathbb{P}\left(A_k^- \cap \left\{\alpha_n(2\delta) \leq \alpha_n(t_k) \frac{1-2\delta}{1-t_k}\right\}\right). \end{aligned}$$

Now, $\frac{1-2\delta}{1-t_k} \stackrel{(1)}{\geq} \frac{1}{2}$ implies that $\forall 1 \leq k \leq m$

$$\begin{aligned} A_k^+ \cap \left\{\alpha_n(2\delta) \geq \alpha_n(t_k) \frac{1-2\delta}{1-t_k}\right\} &\subset A_k^+ \cap \{\alpha_n(2\delta) \geq \varepsilon/6\} \text{ and} \\ A_k^- \cap \left\{\alpha_n(2\delta) \leq \alpha_n(t_k) \frac{1-2\delta}{1-t_k}\right\} &\subset A_k^- \cap \{\alpha_n(2\delta) \leq -\varepsilon/6\}, \end{aligned}$$

whence (noticing that the A_k^+ 's as well as the A_k^- 's are pairwise disjoint (p.d.))

$$\begin{aligned} &\mathbb{P}\left(\sup_{t \in T_m} |\alpha_n(t)| > \varepsilon\right) \leq \\ &\mathbb{P}\left(\sum_{i \leq n} 1_{[0, \delta]}(\eta_i) > \frac{n}{2}\right) + 4 \mathbb{P}\left(|\alpha_n(2\delta)| \geq \varepsilon/6\right). \end{aligned}$$

STEP 4: We are now in the position to verify that

$$\lim_{\delta \rightarrow 0} \limsup_{n \rightarrow \infty} \mathbb{P}^*(w_{\alpha_n}(\delta) > \varepsilon) = 0 \quad \forall \varepsilon > 0 :$$

$$\begin{aligned} \mathbb{P}^*(w_{\alpha_n}(\delta) > \varepsilon) &\stackrel{(2)+(3)}{\leq} \left(\frac{1}{\delta} + 1\right) \lim_{m \rightarrow \infty} \mathbb{P}\left(\sup_{t \in T_m} |\alpha_n(t)| > \varepsilon/3\right) \\ &\stackrel{(\text{STEP 3})}{\leq} \left(\frac{1}{\delta} + 1\right) \left(\mathbb{P}\left(\sum_{i \leq n} 1_{[0, \delta]}(\eta_i) > \frac{n}{2}\right) + 4 \mathbb{P}(|\alpha_n(2\delta)| \geq \varepsilon/6)\right) \\ &\stackrel{(\bar{1})}{\leq} \frac{2}{\delta} \left[\mathbb{P}\left(\frac{\sum_{i \leq n} 1_{[0, \delta]}(\eta_i) - n\delta}{\sqrt{n\delta(1-\delta)}} > \frac{n/2 - n\delta}{\sqrt{n\delta(1-\delta)}}\right) + 4\mathbb{P}(|\alpha_n(s\delta)| \geq \varepsilon/6)\right] \\ &\stackrel{CLT}{\xrightarrow{n \rightarrow \infty}} \frac{2}{\delta} \left[0 + 4 \cdot 2 \left(1 - \Phi\left(\frac{\varepsilon}{6\sqrt{2\delta(1-2\delta)}}\right)\right)\right], \end{aligned}$$

where Φ denotes the standard normal df.

Therefore, $\forall \varepsilon > 0$

$$\begin{aligned} \limsup_{n \rightarrow \infty} \mathbb{P}^*(w_{\alpha_n}(\delta) > \varepsilon) &\leq \frac{2}{\delta} \cdot 8 \frac{6\sqrt{2\delta(1-2\delta)}}{\varepsilon} \frac{1}{\sqrt{2\pi}} e^{-\frac{\varepsilon^2}{2 \cdot 36 \cdot 2\delta(1-2\delta)}} \\ &\leq \frac{2}{\delta} \cdot 8 \frac{6\sqrt{2\delta}}{\varepsilon\sqrt{2\pi}} \cdot \frac{144 \cdot \delta(1-2\delta)}{\varepsilon^2} \xrightarrow{\delta \rightarrow 0} 0. \end{aligned} \quad \square$$

PROOF OF THEOREM 1.2.1. According to CT \mathcal{L} -C we have to show (i) and (ii), where

(i) $\zeta_n \xrightarrow[\text{fidi}]{\mathcal{L}} B$, and

(ii) $\lim_{\delta \rightarrow 0} \limsup_{n \rightarrow \infty} \mathbb{P}^*(w_{\zeta_n}(\delta) > \varepsilon) = 0 \quad \forall \varepsilon > 0$.

As before, we skip the standard proof of (i).

PROOF OF (ii). Let $\varepsilon > 0$ be arbitrary; w.l.o.g. let

$$(5) \quad 0 < \delta < \frac{1}{2} \left(\frac{\varepsilon}{12}\right)^2, \quad \delta \leq 1, \quad n\delta \geq 1.$$

As in STEP 1 of the proof above we get

$$\begin{aligned} \mathbb{P}^*(w_{\zeta_n}(\delta) > \varepsilon) &\leq \sum_{\substack{k \in \mathbb{Z}_+ \\ k < \frac{1}{\delta}}} \mathbb{P}^*\left(\sup_{t \in (k\delta, (k+1)\delta] \cap I} |\zeta_n(t) - \zeta_n(k\delta)| > \varepsilon/3\right) \\ &\leq \sum_{\substack{k \in \mathbb{Z}_+ \\ k < \frac{1}{\delta}}} \mathbb{P}\left(\sup_{t \in (k\delta, (k+1)\delta] \cap I \cap \mathbb{Q}} \left|n^{-1/2} \sum_{i=\langle nk\delta \rangle + 1}^{\langle nt \rangle} \xi_i\right| > \varepsilon/3\right) \\ &\leq \left(\frac{1}{\delta} + 1\right) \mathbb{P}\left(\sup_{1 \leq k \leq \langle 2n\delta \rangle} \left|n^{-1/2} \sum_{i \leq k} \xi_i\right| > \varepsilon/3\right). \end{aligned}$$

To obtain an upper estimate for the last expression we make use of the first Lévy-inequality as follows:

Let $m := \langle 2n\delta \rangle$, $S_k := \sum_{i \leq k} \xi_i/n^{\frac{1}{2}}$, $\varepsilon' := \varepsilon/3$, $s_m^2 := \sum_{i \leq m} \text{Var}(\xi_i/n^{\frac{1}{2}}) = m/n = \frac{\langle 2n\delta \rangle}{n} \leq 2\delta$, i.e. $s_m \leq \varepsilon/12$; then

$$\begin{aligned} & \mathbb{P}\left(\sup_{1 \leq k \leq \langle 2n\delta \rangle} \left|n^{-1/2} \sum_{i \leq k} \xi_i\right| > \varepsilon/3\right) = \\ & \mathbb{P}\left(\sup_{1 \leq k \leq m} |S_k| > \varepsilon'\right) \leq \mathbb{P}\left(\sup_{1 \leq k \leq m} S_k > \varepsilon'\right) + \mathbb{P}\left(\sup_{1 \leq k \leq m} (-S_k) \geq \varepsilon'\right) \\ & \stackrel{(1. \text{ Lévy-Ineq.})}{\leq} \frac{a^2}{a^2 - 1} \left[\mathbb{P}(S_m \geq \varepsilon' - as_m) + \mathbb{P}(-S_m \geq \varepsilon' - as_m)\right] \end{aligned}$$

for all $a > 1$. Taking $a = 2$ and noticing that $\varepsilon' - 2s_m \geq \varepsilon/3 - 2\varepsilon/12 = \varepsilon/6 > 0$, the last expression is

$$\leq \frac{4}{3} \mathbb{P}(|S_m| \geq \varepsilon/6) = \frac{4}{3} \mathbb{P}\left(|n^{-1/2} \sum_{i \leq \langle 2n\delta \rangle} \xi_i| \geq \varepsilon/6\right).$$

Therefore (note that $1 \stackrel{(5)}{\leq} \frac{1}{\delta}$) we get

$$\begin{aligned} & \mathbb{P}^*(w_{\zeta_n}(\delta) > \varepsilon) \leq \\ & \frac{2}{\delta} \frac{4}{3} \mathbb{P}\left(|n^{-1/2} \sum_{i \leq \langle 2n\delta \rangle} \xi_i| \geq \varepsilon/6\right) = \frac{8}{3\delta} \mathbb{P}\left(|\langle 2n\delta \rangle^{-1/2} \sum_{i \leq \langle 2n\delta \rangle} \xi_i| \geq \left(\frac{n}{\langle 2n\delta \rangle}\right)^{1/2} \frac{\varepsilon}{6}\right) \\ & \leq \frac{8}{3\delta} \mathbb{P}\left(|\langle 2n\delta \rangle^{-1/2} \sum_{i \leq \langle 2n\delta \rangle} \xi_i| \geq \frac{\varepsilon}{6\sqrt{2\delta}}\right) \\ & \stackrel{CLT}{n \rightarrow \infty} \frac{8}{3\delta} 2 \left(1 - \Phi\left(\frac{\varepsilon}{6\sqrt{2\delta}}\right)\right) \xrightarrow{\delta \rightarrow 0} 0 \quad (\text{as in Step 4 above}). \quad \square \end{aligned}$$

1.3 The multivariate case

Let $d \geq 1$ and $\eta_j, j \in \mathbb{N}$, be iid random vectors uniformly distributed on $I^d = [0, 1]^d$, defined on a basic p-space $(\Omega, \mathcal{A}, \mathbb{P})$, i.e. $\eta_j : \Omega \rightarrow I^d$ with $\mathbb{P}(\eta_j \leq \underline{t}) = F(\underline{t}) := \prod_{i \leq d} t_i \forall \underline{t} := (t_1, \dots, t_d) \in I^d$. Let $\alpha_n = \alpha_n(\underline{t})_{\underline{t} \in I^d}$ be defined by

$$\alpha_n(\underline{t}) := n^{1/2} (F_n(\underline{t}) - F(\underline{t})), \quad \underline{t} \in I^d,$$

where $F_n(\underline{t}) := n^{-1} \sum_{j \leq n} 1_{[0, \underline{t}]}(\eta_j)$ and $[0, \underline{t}] = [0, t_1] \times \dots \times [0, t_d]$.

The stochastic process $\alpha_n = (\alpha_n(\underline{t}))_{\underline{t} \in I^d}$ is called MULTIVARIATE UNIFORM EMPIRICAL PROCESS (of sample size n).

The MULTIVARIATE (standardized) PARTIAL-SUM PROCESS (of sample size n) $\zeta_n = (\zeta_n(\underline{t}))_{\underline{t} \in I^d}$ is defined by

$$\zeta_n(\underline{t}) := n^{-d/2} \sum_{\underline{j} \in J_n: \underline{j}/n \in [0, \underline{t}]} \xi_{\underline{j}}, \quad \underline{t} \in I^d,$$

where $J_n := \{1, \dots, n\}^d$, $\underline{j} = (j_1, \dots, j_d)$, and where the rv's $\xi_{\underline{j}}, \underline{j} \in \mathbb{N}^d$, are assumed to be iid with $\mathbb{E}(\xi_{\underline{j}}) = 0$ and $\mathbb{E}(\xi_{\underline{j}}^2) = 1$.

The EMPIRICAL MEASURE ν_n pertaining to $F_n = (F_n(\underline{t}))_{\underline{t} \in I^d}$ is given by $\nu_n = n^{-1} \sum_{j \leq n} \delta_{\eta_j}$, where $\delta_{\underline{y}}$ denotes the Dirac measure in $\underline{y} \in I^d$.

The following picture illustrates ν_n in comparison with ζ_n :

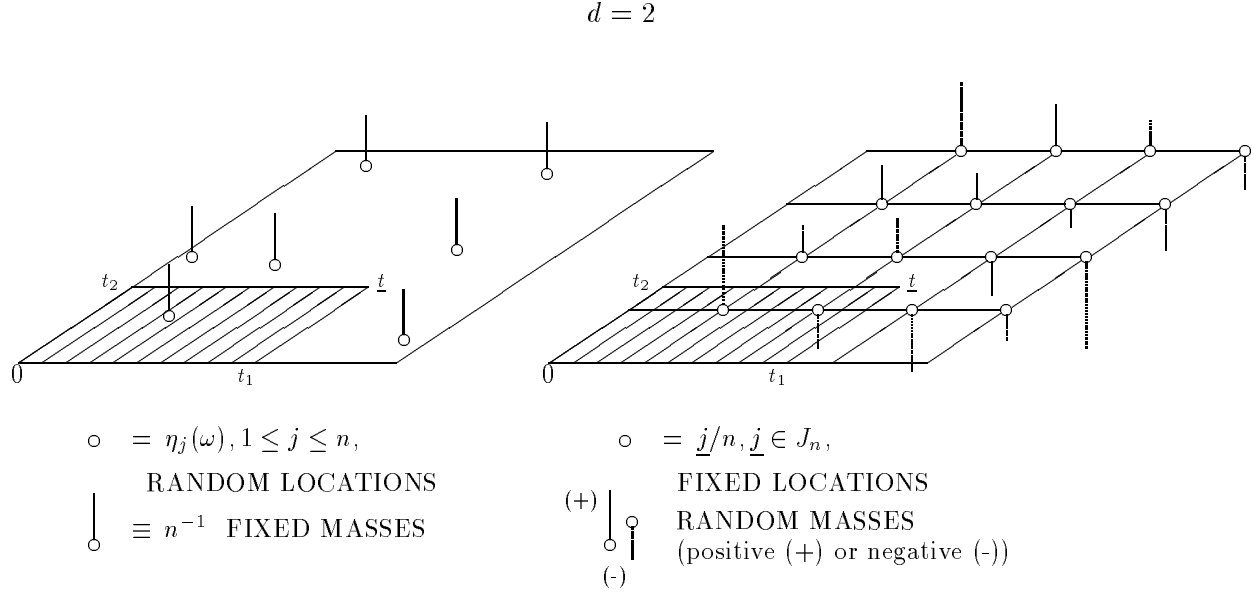

Generalizations of the FCLT's 1.1.6 and 1.2.1 to the multivariate case were obtained by Bickel and Wichura [Bi71], Neuhaus [Ne71] and Straf [Str71] after having extended the Skorokhod-metric to $D(I^d), d > 1$, to ensure the necessary measurability of the processes considered. In contrast, based on the concept of weak convergence (\mathcal{L} -convergence) of Hoffmann-Jørgensen [Ho84], [Ho91] in section 2.3 below, the corresponding FCLT's for α_n and ζ_n in the multivariate case can also be obtained in a much simpler way by choosing a proper metric space, endowed with its natural sup-metric, as sample space of the processes, where the α_n 's and ζ_n 's need not be measurable as we shall see (cf. section 7).

1.4 α_n and ζ_n as set-indexed processes

Identifying each $\underline{t} \in I^d$ with the quadrant $C := [0, \underline{t}] \subset I^d, d \geq 1$, one gets the representations

$$(1.4.1) \quad \alpha_n(C) = n^{1/2}(\nu_n(C) - \nu(C)), \quad C \in \mathcal{C},$$

$$\text{where } \nu_n(C) = n^{-1} \sum_{j \leq n} 1_C(\eta_j) \quad \text{and}$$

$$\nu := \text{Lebesgue measure on } I^d, \text{ and}$$

$$(1.4.2) \quad \zeta_n(C) = n^{-d/2} \sum_{\underline{j} \in J_n} 1_C(\underline{j}/n) \xi_{\underline{j}}, \quad C \in \mathcal{C},$$

$$(1.4.3) \quad \text{with } \mathcal{C} := \{[0, \underline{t}] : \underline{t} \in I^d\}.$$

Both processes can be considered as set-indexed Partial-sum processes with random or fixed locations. Their sample paths are contained in the Banachspace

$$l^\infty(\mathcal{C}) := \{x : \mathcal{C} \rightarrow \mathbb{R} : \|x\|_{\mathcal{C}} := \sup_{C \in \mathcal{C}} |x(C)| < \infty\},$$

endowed with the sup-norm $\|\cdot\|_{\mathcal{C}}$.

Moreover, both processes will occur as special cases of so-called RANDOM MEASURE PROCESSES to be considered in section 3.

1.5 A first glance at Glivenko-Cantelli convergence and Vapnik-Chervonenkis classes of sets

(Cf. also [Gae79] at this place.)

Let $\xi_j, j \in \mathbb{N}$, be iid rv's with $\nu := \mathcal{L}\{\xi_j\}$, defined on a basic p-space $(\Omega, \mathcal{A}, \mathbb{P})$; then the classical GLIVENKO-CANTELLI THEOREM ([Gl33], [Ca33]) states:

$$(1.5.1) \quad \forall \nu \quad \sup_{C \in \mathcal{C}} |\nu_n(C) - \nu(C)| \rightarrow 0 \quad \mathbb{P} - a.s.,$$

$$\text{where } \nu_n(C) = n^{-1} \sum_{j \leq n} 1_C(\xi_j) \quad \text{and}$$

$$\mathcal{C} := \{(-\infty, t] : t \in \mathbb{R}\}.$$

There are a lot of generalizations of (1.5.1) in the literature. Let us mention here only a few of them:

$$(1.5.2) \quad \text{Wolfowitz [Wo60], Dehardt [De71]}$$

(1.5.1) is also valid for re's ξ_j in $(\mathbb{R}^d, \mathcal{B}^d), d \geq 1$,
being iid with law ν and with $\mathcal{C} := \{(-\infty, \underline{t}] : \underline{t} \in \mathbb{R}^d\}$.
($\mathcal{B}^d :=$ Borel σ -field in \mathbb{R}^d .)

$$(1.5.3) \quad \text{Ranga Rao [Ra62]}$$

(1.5.1) is also valid for re's ξ_j in $(\mathbb{R}^d, \mathcal{B}^d), d \geq 1$,
being iid with law ν and with $\mathcal{C} := \{C = \bigcap_{i \leq m} H_i : H_i \text{ halfspace in } \mathbb{R}^d\}$,
where $m \in \mathbb{N}$ is arbitrary but fixed.

$$(1.5.4) \quad \text{Elker-Pollard-Stute [El79]}$$

(1.5.1) is also valid for re's ξ_j in $(\mathbb{R}^d, \mathcal{B}^d), d \geq 1$,
being iid with law ν and with $\mathcal{C} := \{C \subset \mathbb{R}^d : C \text{ closed Euclidian ball}\}$.

The proofs of (1.5.2) - (1.5.4) are mainly based on geometric arguments.

That Glivenko-Cantelli convergence fails to hold for any ν when choosing larger classes of sets can be seen from the following

1.5.5 Example.

Let $d \geq 2$ and $\mathcal{C} := \{C \subset \mathbb{R}^d : C \text{ convex Borel set}\}$; let ν be the (normalized) uniform distribution on the unit sphere S_1 in \mathbb{R}^d and $\xi_j, j \in \mathbb{N}$, be identically distributed with $\mathcal{L}\{\xi_j\} = \nu$ (defined on $(\Omega, \mathcal{A}, \mathbb{P})$). Let ν_n be the empirical measure based on ξ_1, \dots, ξ_n ; then $\forall n \in \mathbb{N}$

$$\sup_{C \in \mathcal{C}} |\nu_n(C) - \nu(C)| = 1 \quad \mathbb{P} - a.s.$$

In fact, given any $x_j = \xi_j(\omega), 1 \leq j \leq n$, where $\xi_j(\omega) \in S_1$ for \mathbb{P} -almost all $\omega \in \Omega$, there exists a $C \in \mathcal{C}$ with $C \subset \{z \in \mathbb{R}^d : |z| \leq 1\}$ s.t. $C \cap S_1 = \{x_1, \dots, x_n\}$: Choose $C := \text{co}(\{x_1, \dots, x_n\})$ where $\text{co}(A)$ denotes the convex hull of $A \subset \mathbb{R}^d$. But then $\nu_n(C) = 1$, whereas $\nu(C) = 0$.

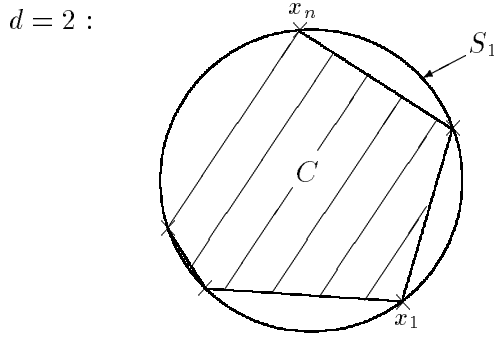

Choosing even $C = \mathcal{B}^d$ one gets for iid re's ξ_j in $(\mathbb{R}^d, \mathcal{B}^d)$ with law ν :

1.5.6 Lemma.

The following assertions are equivalent:

- (i) $\exists \Omega_0 \in \mathcal{A}$ with $\mathbb{P}(\Omega_0) = 1$ s.t. $\sup_{C \in \mathcal{B}^d} |\nu_n(C, \omega) - \nu(C)| \rightarrow 0 \quad \forall \omega \in \Omega_0$.
- (ii) ν is discrete, i.e. $\nu = \sum_{i \in N} m_i \delta_{x_i}, x_i \in \mathbb{R}^d, m_i > 0, \sum_{i \in N} m_i = 1, N \subset \mathbb{N}$.

PROOF. (i) \implies (ii): By assumption there exists $\Omega_0 \in \mathcal{A}$ with $\mathbb{P}(\Omega_0) = 1$ s.t. $\sup_{C \in \mathcal{B}^d} |\nu_n(C, \omega) - \nu(C)| \rightarrow 0 \quad \forall \omega \in \Omega_0$; thus $\Omega_0 \neq \emptyset$ and for $\omega_0 \in \Omega_0$ we have $\lim_{n \rightarrow \infty} \nu_n(C, \omega_0) = \nu(C) \quad \forall C \in \mathcal{B}^d$, whence for $C_0 := \{\xi_j(\omega_0) : j \in \mathbb{N}\} \in \mathcal{B}^d \quad \nu(C_0) = \lim_{n \rightarrow \infty} \nu_n(C_0, \omega_0) = 1$, since $\nu_n(C_0, \omega_0) = 1 \quad \forall n \in \mathbb{N}$ by definition of C_0 . But $\nu(C_0) = 1$ implies that ν is discrete.

(ii) \implies (i): Let ν be discrete, i.e. $\nu = \sum_{i \in N} m_i \delta_{x_i}, x_i \in \mathbb{R}^d, m_i > 0, \sum_{i \in N} m_i = 1, N \subset \mathbb{N}$; then, by the strong law of large numbers, there exists $N_1 \in \mathcal{A}$ with $\mathbb{P}(N_1) = 0$ s.t. $\forall \omega \in \mathcal{C}N_1$ and $\forall i \in N \quad \lim_{n \rightarrow \infty} \nu_n(\{x_i\}, \omega) = \nu(\{x_i\})$. Furthermore, since ν concentrates on $D := \{x_i : i \in N\}$, there exists $N_2 \in \mathcal{A}$ with $\mathbb{P}(N_2) = 0$ s.t. $\forall \omega \in \mathcal{C}N_2$ and $\forall n \in \mathbb{N} \quad \nu_n(A, \omega) = 0 \quad \forall A \subset \mathbb{R}^d \setminus D$. Therefore, $\forall \omega \in \mathcal{C}(N_1 \cup N_2) \quad (\nu_n(\cdot, \omega))_{n \in \mathbb{N}}$ is a sequence of

In contrast, considering again 1.5.5 and choosing for any $s \in \mathbb{N}$ $F := \{x_1, \dots, x_s\}$ with pairwise different $x_i \in S_1$, it follows that every subset $F' = \{x_{i_1}, \dots, x_{i_k}\}$ of F can be represented as $F' = F \cap C$ with a convex Borel set C :

Choose $C := \text{co}(\{x_{i_1}, \dots, x_{i_k}\})$.

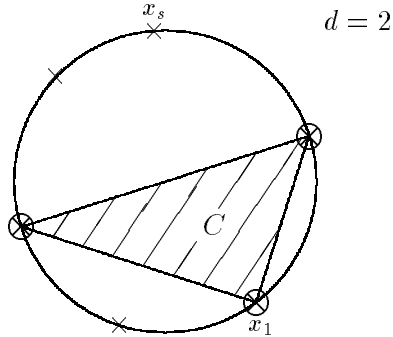

$$\begin{aligned} F &= \{x_1, \dots, x_s\} \subset S_1 \\ F' &= \{\otimes\} \\ C &= \text{co}(F'). \end{aligned}$$

The next example of Durst and Dudley [Dur80] shows that (1.5.8) may fail to hold for a VCC without imposing additional measurability assumptions (cf. [Gae83], p.37-38):

1.5.10 Example.

Let $X = (X, <)$ be an uncountable well-ordered set such that all its initial segments $\{x \in X : x < y\}, y \in X$, are countable (cf. [Ke61], p.29-). Then $\mathcal{C} := \{\{x \in X : x < y\}, y \in X\}$ does not shatter any $F \subset X$ with $|F| = 2$ (in fact: $\forall F = \{x_1, x_2\} \subset X$ with $x_1 < x_2$ we have $\{x_2\} \neq F \cap C \forall C \in \mathcal{C}$, since $x_2 \in C$ would necessarily imply that $x_1 \in C \forall C \in \mathcal{C}$).

Note that \mathcal{C} is linearly ordered by inclusion.

Now, by choosing ν properly, we will see that

$$\sup_{C \in \mathcal{C}} |\nu_n(C) - \nu(C)| \equiv 1 :$$

For this, let $\mathcal{X} := \{B \subset X : B \text{ countable or } \complement B \text{ countable}\}$, and let ν on \mathcal{X} be defined by

$$\nu(B) := \begin{cases} 0 & , \text{ if } B \text{ is countable} \\ 1 & , \text{ if } \complement B \text{ is countable} \end{cases} , B \in \mathcal{X}.$$

Then $\mathcal{C} \subset \mathcal{X}$ and $\nu(C) = 0 \forall C \in \mathcal{C}$.

On the other hand, given any observations $x_i, 1 \leq i \leq n, n \in \mathbb{N}$, of iid re's ξ_1, \dots, ξ_n in $X = (X, \mathcal{X})$ with $\mathcal{L}\{\xi_j\} = \nu$, there exists a $C \in \mathcal{C}$ s.t. $x_i \in C \forall 1 \leq i \leq n$, whence

$$\sup_{C \in \mathcal{C}} |\nu_n(C) - \nu(C)| \equiv 1.$$

To avoid discussions about measurability assumptions we shall usually assume for simplicity that the index sets like $\mathcal{C} \subset \mathcal{X}$ are countable.

Even so, note that in cases where

$$\sup_{C \in \mathcal{C}} |\nu_n(C) - \nu(C)| = \sup_{C \in \mathcal{C}_0} |\nu_n(C) - \nu(C)|$$

with a countable $\mathcal{C}_0 \subset \mathcal{C}$, this is no restriction.

Also in case of empirical processes and partial-sum processes considered in 1.1 and 1.2, respectively, their sample paths are completely determined through the behaviour on a countable index set.

When considering later classes \mathcal{F} of measurable functions $f : X \rightarrow \mathbb{R}$ (instead of $1_{\mathcal{C}} \equiv \{1_C : C \in \mathcal{C}\}$) there will be instances where $\forall \delta_j \in \{-1, 1\}, 1 \leq j \leq n$,

$$(+) \quad \left\| \sum_{j \leq n} \delta_j f(x_j) \right\|_{\mathcal{F}} := \sup_{f \in \mathcal{F}} \left| \sum_{j \leq n} \delta_j f(x_j) \right| = \sup_{f \in \mathcal{F}_0} \left| \sum_{j \leq n} \delta_j f(x_j) \right|$$

for a countable subclass \mathcal{F}_0 of \mathcal{F} , implying measurability of $(x_1, \dots, x_n) \mapsto \left\| \sum_{j \leq n} \delta_j f(x_j) \right\|_{\mathcal{F}}$. The underlying measurability concept can be found in [Va96], Example 2.3.4, called there “Pointwise measurability of \mathcal{F} ” which means that there exists a countable $\mathcal{F}_0 \subset \mathcal{F}$ s.t. $\forall f \in \mathcal{F}$ there exists a sequence $(f_n) \subset \mathcal{F}_0$ with $f_n(x) \rightarrow f(x) \forall x \in X$. In fact, this property implies (+): It is enough to show that for any $\varepsilon > 0$ there exists $f_{n_0} \in \mathcal{F}_0$ s.t. $\left| \sum_{j \leq n} \delta_j f_{n_0}(x_j) \right| > \left\| \sum_{j \leq n} \delta_j f(x_j) \right\|_{\mathcal{F}} - \varepsilon$. For this, choose $f \in \mathcal{F}$ with $\left| \sum_{j \leq n} \delta_j f(x_j) \right| > \left\| \sum_{j \leq n} \delta_j f(x_j) \right\|_{\mathcal{F}} - \varepsilon/2$ and $(f_m) \subset \mathcal{F}_0$ s.t. $f_m(x_j) \rightarrow f(x_j)$ as $m \rightarrow \infty \quad \forall 1 \leq j \leq n$ which implies $\left| \sum_{j \leq n} \delta_j f_m(x_j) \right| \rightarrow \left| \sum_{j \leq n} \delta_j f(x_j) \right|$ whence there exists an n_0 s.t. $\left| \sum_{j \leq n} \delta_j f_{n_0}(x_j) \right| > \left\| \sum_{j \leq n} \delta_j f(x_j) \right\|_{\mathcal{F}} - \varepsilon$.

For more about measurability concepts we refer to [Du99].

When restricting to countable $\mathcal{C} \subset \mathcal{X}$ one may wonder if one ends up with a VCC; this is not the case as seen by the following example:

Let $(X, \mathcal{X}) := (\mathbb{R}, \mathcal{B})$, $J_1 := \{[a, b] : a < b, a, b \in \mathbb{Q}\}$ and $\forall n \in \mathbb{N} \quad J(n) := \bigcup_{i \leq n} J_i$ with $J_i \equiv J_1$. Then $\mathcal{C} := \bigcup_{n \in \mathbb{N}} J(n)$ is a countable subclass of \mathcal{B} with with the following property:

$$\forall n \in \mathbb{N} \quad \exists F \subset \mathbb{R} \quad \text{with } |F| = n \text{ s.t. } |\{F \cap C : C \in \mathcal{C}\}| = 2^n,$$

i.e. \mathcal{C} is not a VCC.

More about VCC’s in arbitrary sample spaces $X = (X, \mathcal{X})$ and so-called Vapnik-Chervonenkis graph classes (VCGC) of \mathcal{X} -measurable functions $f : X \rightarrow \mathbb{R}$ will be contained in sections 4.2 and 4.3 below.

2 Empirical Measures in general sample spaces

2.1 Empirical Discrepancies, Glivenko-Cantelli convergence and some consequences in statistics

Let $X = (X, \mathcal{X})$ be an arbitrary measurable space serving as sample space of iid re's $\xi_j, j \in \mathbb{N}$, with $\mathcal{L}\{\xi_j\} = \nu$, defined as coordinate projections on $(\Omega, \mathcal{A}, \mathbb{P}) := (X^{\mathbb{N}}, \mathcal{X}^{\mathbb{N}}, \nu^{\mathbb{N}})$, i.e.our basic model will be the canonical one as introduced in section 1.5.

Let ν_n be the empirical measure based on ξ_1, \dots, ξ_n (cf.(1.5.7)) and let $\mathcal{C} \subset \mathcal{X}$ be arbitrary but countable for simplicity. The so-called EMPIRICAL DISCREPANCY is defined by

$$(2.1.1) \quad \|\nu_n - \nu\|_{\mathcal{C}} := \sup_{C \in \mathcal{C}} |\nu_n(C) - \nu(C)|$$

(Since \mathcal{C} is supposed to be countable, $\|\nu_n - \nu\|_{\mathcal{C}}$ is a rv, defined on $(\Omega, \mathcal{A}, \mathbb{P})$.)

The empirical discrepancies have the following property; in case of arbitrary (i.e. not necessarily countable) index sets we refer to [St95]:

2.1.2 Lemma.

$(\|\nu_n - \nu\|_{\mathcal{C}})_{n \in \mathbb{N}}$ is a reversed sub-martingale w.r.t. the sequence $(\mathcal{G}_n)_{n \in \mathbb{N}}$ of σ -fields

$$\mathcal{G}_n := \sigma(\{\nu_k(B) : k \geq n, B \in \mathcal{X}\}),$$

i.e. $\|\nu_n - \nu\|_{\mathcal{C}}$ is \mathcal{G}_n -measurable and \mathbb{P} -integrable $\forall n \in \mathbb{N}$, and $\forall n, m \in \mathbb{N}$ with $m \leq n$ one has

$$(2.1.3) \quad \|\nu_n - \nu\|_{\mathcal{C}} \leq \mathbb{E}(\|\nu_m - \nu\|_{\mathcal{C}} | \mathcal{G}_n) \quad \mathbb{P} - a.s.$$

PROOF. As shown in [Gae77], 6.5.5(c), the following holds:

$\forall C \in \mathcal{C}$ the sequence $(\nu_n(C) - \nu(C))_{n \in \mathbb{N}}$ is a reversed martingale w.r.t. $(\mathcal{G}_n)_{n \in \mathbb{N}}$, i.e. $\forall n, m \in \mathbb{N}$ with $m \leq n$ one has

$$\nu_n(C) - \nu(C) = \mathbb{E}((\nu_m(C) - \nu(C)) | \mathcal{G}_n) \quad \mathbb{P} - a.s.;$$

therefore, since \mathcal{C} is countable, it follows that $\mathbb{P} - a.s.$

$$\begin{aligned} \sup_{C \in \mathcal{C}} |\nu_n(C) - \nu(C)| &= \\ \sup_{C \in \mathcal{C}} |\mathbb{E}((\nu_m(C) - \nu(C)) | \mathcal{G}_n)| &\leq \mathbb{E}(\sup_{C \in \mathcal{C}} |\nu_m(C) - \nu(C)| | \mathcal{G}_n), \end{aligned}$$

i.e. (2.1.3). □

Now, as in the case of sub-martingales, there holds an analogous CONVERGENCE THEOREM FOR REVERSED SUB-MARTINGALES (cf. e.g.[Gae77], 6.5.10) stating that for any reversed sub-martingale $(T_n)_{n \in \mathbb{N}}$ (on some p-space $(\Omega, \mathcal{A}, \mathbb{P})$) w.r.t. a monotone decseasing sequence $(\mathcal{G}_n)_{n \in \mathbb{N}}$ of

sub- σ -fields of \mathcal{A} satisfying the condition that $\inf_{n \in \mathbb{N}} \mathbb{E}(T_n) > -\infty$ there exists an \mathbb{P} -integrable rv. T_∞ s.t. $T_n \rightarrow T_\infty$ \mathbb{P} -a.s. and in the mean.

From this and Lemma 2.1.2 one obtains a rather simple proof of the following result (cf. [Po81]) which, in a similar form, was one of the main results in [Ste78] proved there with different methods based on ergodic theory of subadditive processes.

2.1.4 Lemma.

Let $(\tau_n)_{n \in \mathbb{N}}$ be an arbitrary sequence of non-negative integer-valued rv's on $(\Omega, \mathcal{A}, \mathbb{P})$ such that $\tau_n \xrightarrow{\mathbb{P}} \infty$ (where $\xrightarrow{\mathbb{P}}$ denotes convergence in probability); then

$$\|\nu_n - \nu\|_{\mathcal{C}} \rightarrow 0 \quad \mathbb{P} - a.s. \iff \|\nu_{\tau_n} - \nu\|_{\mathcal{C}} \xrightarrow{\mathbb{P}} 0;$$

in particular, $\|\nu_n - \nu\|_{\mathcal{C}} \xrightarrow{\mathbb{P}} 0 \implies \|\nu_n - \nu\|_{\mathcal{C}} \rightarrow 0 \quad \mathbb{P} - a.s.$, whence

$$(2.1.5) \quad \mathbb{E}(\|\nu_n - \nu\|_{\mathcal{C}}) \rightarrow 0 \implies \|\nu_n - \nu\|_{\mathcal{C}} \rightarrow 0 \quad \mathbb{P} - a.s.$$

Note that (2.1.5) will lead later to an essential simplification in proving Glivenko-Cantelli convergence of $\nu_n = (\nu_n(C))_{C \in \mathcal{C}}$. Especially we will obtain along this way (cf. section 6.3) the following fundamental result of Vapnik-Chervonenkis ([Vap71]):

2.1.6 THEOREM.

Let $\mathcal{C} \subset \mathcal{X}$ be a VCC; then – under appropriate measurability conditions – it is true that $\forall \nu$ one has

$$\|\nu_n - \nu\|_{\mathcal{C}} \rightarrow 0 \quad \mathbb{P} - a.s.$$

PROOF OF 2.1.4 \implies : $\tau_n \xrightarrow{\mathbb{P}} \infty$ implies that for any subsequence $(\tau_{n'})$ of (τ_n) there exists a further subsequence $(\tau_{n''})$ s.t. $\tau_{n''} \rightarrow \infty$ \mathbb{P} -a.s., whence $\|\nu_{\tau_{n''}} - \nu\| \rightarrow 0$ \mathbb{P} -a.s. as n'' tends to infinity, and therefore $\|\nu_{\tau_n} - \nu\|_{\mathcal{C}} \xrightarrow{\mathbb{P}} 0$.

\Leftarrow : According to 2.1.2 $(\|\nu_n - \nu\|_{\mathcal{C}})_{n \in \mathbb{N}}$ is a reversed sub-martingale. It is uniformly bounded; therefore, by the convergence theorem for reversed sub-martingales mentioned before, there exists an \mathbb{P} -integrable rv T_∞ s.t. $\|\nu_n - \nu\|_{\mathcal{C}} \rightarrow T_\infty$ \mathbb{P} -a.s. From this it follows as in the first part of our proof that $\|\nu_{\tau_n} - \nu\|_{\mathcal{C}} \xrightarrow{\mathbb{P}} T_\infty$ whence, by assumption, it follows that $T_\infty = 0$ \mathbb{P} -a.s. \square

Some consequences in statistics

In his book on Probability Theory Alfred Rényi considers the (classical) Glivenko-Cantelli theorem to be the “Fundamental Theorem of Mathematical Statistics” ([Re70], Chap.VII, §8). Given data x_1, x_2, \dots viewed as realizations of re's ξ_1, ξ_2, \dots in (X, \mathcal{X}) with $\mathcal{L}\{\xi_i\} = \nu$, Theorem 2.1.6 yields information about an unknown ν through its “statistical pictures” in form of the empirical measures

ν_n , e.g. in connection with a test for the null-hypothesis $H^0 : \nu = \nu_0$, ν_0 being a given hypothetical distribution on \mathcal{X} , versus the alternative $H^1 : \nu \neq \nu_0$. In the classical case the corresponding Kolmogorov-test is based on the test-statistic

$$D_n(\mathcal{C}, \nu_0) \equiv \|\nu_n - \nu_0\|_{\mathcal{C}}$$

with (cf. (1.5.2)) $\mathcal{C} := \{(-\infty, \underline{t}] : \underline{t} \in \mathbb{R}^d\}$:

$$\text{Reject } H^0 \quad \text{if } D_n(\mathcal{C}, \nu_0) > c, \quad c > 0.$$

Another possibility would be to use a Kolmogorov-test based on

$$D_n(\mathcal{C}_0, \nu_0) \quad \text{with } \mathcal{C}_0 := \{x + C_0 : x \in \mathbb{R}^d\},$$

where C_0 is a given closed Euclidian ball. Also in this case one has for any ν that for the so-called “scan-statistic”

$$\lim_{n \rightarrow \infty} D_n(\mathcal{C}_0, \nu) = 0 \quad \mathbb{P} - a.s. \quad (\text{cf. (1.5.4)}),$$

and under $H^1 : \nu \neq \nu_0$ one has

$$\lim_{n \rightarrow \infty} D_n(\mathcal{C}_0, \nu_0) = d \quad \mathbb{P} - a.s.,$$

where $d := \|\nu - \nu_0\|_{\mathcal{C}} > 0$ (cf. [Py84], Theorem 6.1), i.e. Kolmogorov-tests based on $D_n(\mathcal{C}_0, \nu_0)$ are also consistent against all alternatives.

Furthermore, simulation results in [Py84], Section 6, indicated a considerable improvement in power that is possible when using the scan-statistic $D_n(\mathcal{C}_0, \nu_0)$ instead of $D_n(\mathcal{C}, \nu_0)$; cf. also the very interesting Monte-Carlo study of Pyke and Wilbour ([Py88]) concerning the power of such tests; as mentioned in [We92] it would be of some interest to have available sufficient theory in order to theoretically compute (or at least approximate) the power of their tests.

2.2 Functional Central Limit Theorems for set-indexed empirical and partial-sum processes, respectively

Let $X = (X, \mathcal{X})$ be an arbitrary sample space, $\eta_j, j \in \mathbb{N}$, be iid re's in X , $\nu = \mathcal{L}\{\eta_j\}$, and ν_n be the empirical measure based on η_1, \dots, η_n . Let $\mathcal{C} \subset \mathcal{X}$ be a VCC and $\beta_n = (\beta_n(C))_{C \in \mathcal{C}}$ be the *empirical \mathcal{C} -process* (of sample size n), defined by

$$\beta_n(C) := n^{1/2}(\nu_n(C) - \nu(C)), \quad C \in \mathcal{C}.$$

Then, under appropriate measurability conditions, the following generalization of Theorem 1.1.6 has been obtained by Dudley:

2.2.1 THEOREM ([Du78]).

$$\beta_n \xrightarrow{\mathcal{L}} \mathbb{G}_\nu \quad \text{in } (l^\infty(\mathcal{C}), \|\cdot\|_{\mathcal{C}}),$$

where $\mathbb{G}_\nu = (G_\nu(C))_{C \in \mathcal{C}}$ is a mean-zero Gaussian process whose covariance structure is given by

$$\text{cov}(G_\nu(C_1), G_\nu(C_2)) = \nu(C_1 \cap C_2) - \nu(C_1)\nu(C_2), \quad C_1, C_2 \in \mathcal{C},$$

and $\xrightarrow{\mathcal{L}}$ -convergence is defined as in section 2.3 below.

The sample paths of \mathbb{G}_ν are contained in the space

$$U^b(\mathcal{C}, d_\nu) := \{x \in l^\infty(\mathcal{C}) : x \text{ uniformly } d_\nu\text{-continuous}\},$$

d_ν being the pseudo-metric in \mathcal{C} , defined by $d_\nu(C_1, C_2) := \nu(C_1 \Delta C_2)$, $C_1, C_2 \in \mathcal{C}$.

($C_1 \Delta C_2$ denotes the symmetric difference between C_1 and C_2 ; note that a pseudo-metric has all properties of a metric besides that $d_\nu(C_1, C_2) = 0$ does not imply $C_1 = C_2$.)

Compare Theorem 2.2.1 with Theorem 1.1.6 in case of the uniform empirical process α_n , where $X = I \equiv [0, 1]$, $\mathcal{X} = I \cap \mathcal{B}$, $\nu =$ Lebesgue measure on \mathcal{X} , $\mathcal{C} = \{[0, t] : t \in I\}$ being a VCC, $d_\nu(C_1, C_2) = |t_1 - t_2|$ for $C_i = [0, t_i]$ and where $U^b(\mathcal{C}, d_\nu) = C \equiv C(I)$.

Functional Central Limit Theorems (FCLT's) for set-indexed partial-sum processes have been obtained by the SEATTLE-SCHOOL around Ron Pyke: cf. [Py84], [Os84], [Ba85], [Os85], [Al86], and section 7.2 below.

At this place here we want to mention only the following two results. The first is concerned with the multivariate (standardized) partial-sum process $\zeta_n = (\zeta_n(C))_{n \in \mathbb{N}}$ of section 1.4 (cf. (1.4.2) and (1.4.3)) generalizing Theorem 1.2.1:

2.2.2 THEOREM ([Al86] and [Gae94], Remark 2.16).

$$\zeta_n \xrightarrow{\mathcal{L}} \mathbb{G}_\nu \quad \text{in } (l^\infty(\mathcal{C}), \|\cdot\|_{\mathcal{C}}), \quad \nu \equiv \text{Lebesgue measure on } I^d,$$

where $\mathbb{G}_\nu = (G_\nu(C))_{C \in \mathcal{C}}$ is a mean-zero Gaussian process whose covariance structure is given by

$$\text{cov}(G_\nu(C_1), G_\nu(C_2)) = \nu(C_1 \cap C_2), \quad C_1, C_2 \in \mathcal{C},$$

and again $\xrightarrow{\mathcal{L}}$ -convergence is defined as in section 2.3 below.

Also here the sample paths of \mathbb{G}_ν are contained in $U^b(\mathcal{C}, d_\nu)$.

The second result is concerned with set-indexed partial-sum processes with random locations (cf. 3.2.1 and 7.2 below):

2.2.3 THEOREM (cf. [Gae94], Cor. 2.15).

Let $\mathcal{C} \subset \mathcal{X}$ be a VCC in an arbitrary sample space $X = (X, \mathcal{X})$ and $\xi_{nj} := j(n)^{-1/2}\xi_j$ for each $1 \leq j \leq j(n)$ and $n \in \mathbb{N}$ with $j(n) \rightarrow \infty$ as $n \rightarrow \infty$, the ξ_j 's being iid rv's with $\mathbb{E}(\xi_j) = 0$ and $\mathbb{E}(\xi_j^2) = 1$. Let $(\eta_{nj})_{1 \leq j \leq j(n), n \in \mathbb{N}}$ be a triangular array of rowwise independent (but not necessarily identically distributed) re's in X which is independent of $(\xi_j)_{j \in \mathbb{N}}$.

Assume that there is a p -measure ν on \mathcal{X} s.t. with $\nu_{nj} := \mathcal{L}\{\eta_{nj}\}$ the following two conditions are fulfilled:

- (i) $\lim_{n \rightarrow \infty} j(n)^{-1} \sum_{j \leq j(n)} \nu_{nj}(C \cap D) = \nu(C \cap D) \quad \forall C, D \in \mathcal{C}$
- (ii) $\lim_{\delta \rightarrow 0} \limsup_{n \rightarrow \infty} \sup_{\{C \in \mathcal{C} : \nu(C) \leq \delta\}} j(n)^{-1} \sum_{j \leq j(n)} \nu_{nj}(C) = 0$.

Then

$$\left(j(n)^{-1/2} \sum_{j \leq j(n)} 1_C(\eta_{nj}) \cdot \xi_j \right)_{C \in \mathcal{C}} \xrightarrow{\mathcal{L}} \mathbb{G}_\nu \quad \text{in } (l^\infty(\mathcal{C}), \|\cdot\|_{\mathcal{C}}),$$

where $\mathbb{G}_\nu = (G_\nu(C))_{C \in \mathcal{C}}$ is a mean-zero Gaussian process whose covariance structure is given by

$$\text{cov}(G_\nu(C_1), G_\nu(C_2)) = \nu(C_1 \cap C_2), \quad C_1, C_2 \in \mathcal{C},$$

and again $\xrightarrow{\mathcal{L}}$ -convergence is defined as in section 2.3 below. Also here the sample paths of \mathbb{G}_ν are contained in $U^b(\mathcal{C}, d_\nu)$.

2.3 Weak convergence (\mathcal{L} -convergence) in the sense of Hoffmann-Jørgensen

The classical concept of weak convergence (convergence in law) for random elements (re's) $\eta_n, n \geq 0$, in a metric space $S = (S, \mathcal{B}(S))$, endowed with its Borel σ -field $\mathcal{B}(S)$, is defined by (cf. [Bi68])

$$(2.3.1) \quad \eta_n \xrightarrow{\mathcal{L}} \eta_0 \iff \lim_{n \rightarrow \infty} \mathbb{E}(f \circ \eta_n) = \mathbb{E}(f \circ \eta_0) \quad \forall f \in C^b(S)$$

where $C^b(S) := \{f : S \rightarrow \mathbb{R} : f \text{ continuous and bounded}\}$.

For such η_n 's, being re's in $(S, \mathcal{B}(S))$, their laws $\mathcal{L}\{\eta_n\}$ are well defined on $\mathcal{B}(S)$, whence (2.3.1) is equivalent to

$$(2.3.1') \quad \eta_n \xrightarrow{\mathcal{L}} \eta_0 \iff \lim_{n \rightarrow \infty} \int_S f d\mathcal{L}\{\eta_n\} = \int_S f d\mathcal{L}\{\eta_0\} \quad \forall f \in C^b(S).$$

But, as we have learned from the uniform empirical process, the approximating sequence $(\eta_n)_{n \in \mathbb{N}}$ of a limiting re η_0 may not be ad hoc measurable and this leads to the concept of weak convergence (\mathcal{L} -convergence) in the sense of Hoffmann-Jørgensen ([Ho84], [Ho91]). In this context, i.e. where the η_n 's, $n \in \mathbb{N}$, are allowed to be completely arbitrary maps, we will speak of RANDOM QUANTITIES

(rq's) instead of RANDOM ELEMENTS (re's). So, given a basic p-space $(\Omega, \mathcal{A}, \mathbb{P})$, let $\eta_n : \Omega \rightarrow S$ be rq's and $\eta_0 : \Omega \rightarrow S$ be $\mathcal{A}, \mathcal{B}(S)$ -measurable (i.e. only η_0 is assumed to be a re in $(S, \mathcal{B}(S))$); then:

$$(2.3.2) \quad \eta_n \xrightarrow{\mathcal{L}} \eta_0 \iff \lim_{n \rightarrow \infty} \mathbb{E}^*(f \circ \eta_n) = \mathbb{E}(f \circ \eta_0) \quad \forall f \in C^b(S).$$

Here, given an arbitrary $g : \Omega \rightarrow \overline{\mathbb{R}}$ (defined on a p-space $(\Omega, \mathcal{A}, \mathbb{P})$), the so-called “outer expectation” (“outer integral”) of g w.r.t. \mathbb{P} is defined by

$$(2.3.3) \quad \mathbb{E}^*(g) := \inf\{\mathbb{E}(h) : h \geq g, h : \Omega \rightarrow \overline{\mathbb{R}} \text{ measurable and } \mathbb{E}(h) \text{ exists}\}.$$

In view of (2.3.2) one should note that $\mathbb{E}(f \circ \eta_0)$ is well defined, since $f \in C^b(S) \implies f \mathcal{B}(S), \mathcal{B}$ -measurable and bounded $\implies f \circ \eta_0$ \mathbb{P} -integrable (i.e. $f \circ \eta_0 \in \mathcal{L}(\Omega, \mathcal{A}, \mathbb{P})$). If, in addition, also the η_n 's, $n \in \mathbb{N}$, are $\mathcal{B}(S), \mathcal{B}$ -measurable, then $\mathbb{E}^*(f \circ \eta_n) = \mathbb{E}(f \circ \eta_n)$, i.e. in this case (2.3.2) coincides with the classical definition (2.3.1).

In connection with (2.3.2) the following definitions and formulas are in order:

Let the so-called “inner expectation” (“inner integral”) of $g : \Omega \rightarrow \overline{\mathbb{R}}$ w.r.t. \mathbb{P} be defined by

$$\mathbb{E}_*(g) := \sup\{\mathbb{E}(h) : h \leq g, h : \Omega \rightarrow \overline{\mathbb{R}} \text{ measurable and } \mathbb{E}(h) \text{ exists}\},$$

then, for any $A \subset \Omega$, $\mathbb{E}_*(1_A) = \mathbb{P}_*(A) := \sup\{\mathbb{P}(B) : B \subset A, B \in \mathcal{A}\}$, whereas $\mathbb{E}^*(1_A) = \mathbb{P}^*(A) := \inf\{\mathbb{P}(B) : B \supset A, B \in \mathcal{A}\}$; furthermore

$$(2.3.4) \quad \begin{aligned} \mathbb{E}_*(g) &= -\mathbb{E}^*(-g), \quad \mathbb{E}_*(g) \leq \mathbb{E}^*(g); \\ g_1 \leq g_2 &\implies \mathbb{E}_*(g_1) \leq \mathbb{E}_*(g_2) \text{ and } \mathbb{E}^*(g_1) \leq \mathbb{E}^*(g_2) \\ \mathbb{E}^*(g_1 + g_2) &\leq \mathbb{E}^*(g_1) + \mathbb{E}^*(g_2) \\ |\mathbb{E}^*(g_1) - \mathbb{E}^*(g_2)| &\leq \mathbb{E}^*(|g_1 + g_2|) \quad \text{if } |\mathbb{E}^*(g_i)| < \infty, i = 1, 2; \\ \mathbb{E}_*(g) &= \mathbb{E}^*(g) = \mathbb{E}(g), \quad \text{if } g \in \mathcal{L}(\Omega, \mathcal{A}, \mathbb{P}); \\ \mathbb{P}^*(A) + \mathbb{P}_*(\mathcal{C}A) &= 1 \quad \forall A \subset \Omega. \end{aligned}$$

For some applications it might be useful to allow also rq's $\eta_n, n \in \mathbb{N}$, with values in a larger space $E \supset S$; one may think (in case of stochastic processes with parameter set T) of $E = \mathbb{R}^T \supset S := l^\infty(T)$, where S is endowed with the sup-metric $\|x\|_T := \sup_{t \in T} |x(t)|$; this leads to the following more general model of weak convergence (\mathcal{L} -convergence) considered in [St94]:

(2.3.5) Let $S = (S, s)$ be a metric space (with metric s) and $E \supset S$ be arbitrary; let $\eta_n : \Omega \rightarrow E$ be rq's, $n \in \mathbb{N}$, and $\eta_0 : \Omega \rightarrow S$ be $\mathcal{A}, \mathcal{B}(S)$ -measurable; then

$$(2.3.6) \quad \begin{aligned} \eta_n \xrightarrow{\mathcal{L}} \eta_0 &\iff \lim_{n \rightarrow \infty} \mathbb{E}^*(f \circ \eta_n) = \mathbb{E}(f \circ \eta_0) \\ \forall f : E \rightarrow \mathbb{R}, f &\text{ bounded and } \text{rest}_S(f) \in C^b(S), \text{ where } \text{rest}_S(f) \text{ denotes the} \\ &\text{restriction of } f \text{ onto } S. \end{aligned}$$

If, in addition (compare with the classical situation of section 1), for a separable subspace S_0 of S with $S_0 \in \mathcal{B}(S)$, $\mathbb{P}(\eta_0 \in S_0) = 1$, then the limiting re η_0 is said to be separable and in this case we write $\eta_n \xrightarrow[\text{sep}]{\mathcal{L}} \eta_0$.

Within this general model of \mathcal{L} -convergence the known results from the classical theory of weak convergence, like the Portmanteau-Theorem, Cramér-Slutzky-type result, Continuous Mapping Theorem, etc. remain valid as we shall see below.

In passing we mention the following two facts:

$$(2.3.7) \quad (\text{cf. [Va96], 1.3.7 and 1.3.8(i)}): \quad \eta_n \xrightarrow{\mathcal{L}} \eta_0 \implies \mathbb{E}^*(f \circ \eta_n) - \mathbb{E}_*(f \circ \eta_n) \longrightarrow 0 \\ \forall f : E \longrightarrow \mathbb{R}, f \text{ bounded and } \text{rest}_S(f) \in C^b(S), \text{ i.e. the } \eta_n \text{'s are "asymptotically measurable"}.$$

$$(2.3.8) \quad \eta_n \xrightarrow{\mathcal{L}} \eta_0 \implies \mathbb{P}_*(\eta_n \in S) \longrightarrow 1.$$

In case of stochastic processes $\eta_n = (\eta_n(t))_{t \in T}$, indexed by a pseudo-metric parameter space $T = (T, d)$, being all defined on some basic p-space $(\Omega, \mathcal{A}, \mathbb{P})$, the following theorem characterizes weak convergence (\mathcal{L} -convergence), i.e. $\eta_n \xrightarrow[\text{sep}]{\mathcal{L}} \eta_0$ based on the situation (2.3.5) with $S = (l^\infty(T), \|\cdot\|_T) \subset E = \mathbb{R}^T$.

2.3.9 CHARACTERIZATION THEOREM OF \mathcal{L} -CONVERGENCE (CT \mathcal{L} -C).

Let $\eta_n = (\eta_n(t))_{t \in T}, n \in \mathbb{N}$, be a sequence of stochastic processes, indexed by a pseudo-metric parameter space $T = (T, d)$, being all defined on some basic p-space $(\Omega, \mathcal{A}, \mathbb{P})$ and let $\bar{\eta}_0 = (\bar{\eta}_0(t))_{t \in T}$ be a stochastic process viewed as coordinate process on $(\mathbb{R}^T, \mathcal{B}^T, \mathcal{L}\{\bar{\eta}_0\})$ (where the law $\mathcal{L}\{\bar{\eta}_0\}$ of $\bar{\eta}_0$ is well defined on the product σ -field $\mathcal{B}^T \equiv \bigotimes_T \mathcal{B}$ according to Kolmogorov's theorem) such that

$$(2.3.10) \quad \eta_n \xrightarrow[\text{fidi}]{\mathcal{L}} \bar{\eta}_0, \quad \text{i.e. weak convergence of the finite-dimensional distributions (fidis) of } \eta_n \text{ to the corresponding fidis of } \bar{\eta}_0.$$

Then, if

$$(2.3.11) \quad (T, d) \quad \text{is totally bounded,}$$

and if the so-called "Asymptotic Equicontinuity Condition" (AEC) is fulfilled, i.e. if

$$(2.3.12) \quad \lim_{\delta \rightarrow 0} \limsup_{n \rightarrow \infty} \mathbb{P}^*(w_{\eta_n}(\delta) > \varepsilon) = 0 \quad \forall \varepsilon > 0,$$

there exists a stochastic process $\eta_0 = (\eta_0(t))_{t \in T}$ with sample paths in $S_0 \equiv U^b(T, d) \quad ((U^b(T, d), \|\cdot\|_T)$ being a separable subspace of $S = (l^\infty(T), \|\cdot\|_T)$) such that

$$(2.3.13) \quad \eta_n \xrightarrow[\text{sep}]{\mathcal{L}} \eta_0,$$

where $\eta_0 \stackrel{\mathcal{L}}{\underset{\text{fidi}}{=}} \bar{\eta}_0$, i.e. η_0 and $\bar{\eta}_0$ have the same fidis.

Conversely, (2.3.13) (with $S_0 = (U^b(T, d), \|\cdot\|_T)$ as separable subspace of $S = (l^\infty(T), \|\cdot\|_T)$) implies (2.3.11) and (2.3.12).

Here, $U^b(T, d) := \{x \in l^\infty(T) : x \text{ uniformly } d\text{-continuous}\}$, and for any $x \in \mathbb{R}^T$ and $\delta > 0$

$$w_x(\delta) := \sup_{t, t' \in T, d(t, t') \leq \delta} |x(t) - x(t')|$$

is the oscillation-modulus of x . Note that (2.3.10) will be fulfilled in most of the later applications according to the classical multivariate CLT's.

There are several possibilities presented in the literature for proving the CT \mathcal{L} -C; cf. e.g. [Gi86], [An87], Theorem 5.5, [Po90], Theorem 10.2, [Du92], Theorem 3.7.2, [Gae92], Theorem 3.10, and [Va96], Section 1.5. Independently, we want to give here a different (and as we think rather lucid) proof of 2.3.9 based on the following auxiliary lemma and partially on ideas of [Po90] (cf. STEP 2 below).

AUXILIARY LEMMA (Cf. [Bi68], Cor. 1, p. 14, and [Gae83], Thm. 8).

Given the situation as in (2.3.5), let $S_0 \subset S$ be separable and $\mathbb{P}(\eta_0 \in S_0) = 1$. Suppose that the class

$$\mathcal{C} \subset \{B \in \mathcal{B}(S) : \mathbb{P}(\eta_0 \in \partial B) = 0\}$$

(where ∂B denotes the boundary of B) satisfies

$$(\star) \quad \begin{aligned} &\forall G \text{ open } \subset S \text{ and } \forall x \in G \cap S_0^c \text{ (where } S_0^c \text{ denotes the closure of } S_0 \text{ in } S) \\ &\exists C_x \in \mathcal{C} \text{ s.t. } x \in C_x^0 \subset C_x \subset G \text{ (where } C_x^0 \text{ denotes the interior of } C_x). \end{aligned}$$

Then the following two statements are equivalent:

$$\begin{aligned} (i) \quad &\eta_n \xrightarrow[\text{sep}]{\mathcal{L}} \eta_0 \\ (ii) \quad &\limsup \mathbb{P}^*(\eta_n \in C) \leq \mathbb{P}(\eta_0 \in C) \quad \text{and} \\ &\liminf \mathbb{P}_*(\eta_n \in C) \geq \mathbb{P}(\eta_0 \in C) \quad \forall C \in \mathcal{C}^{\cap f}, \end{aligned}$$

where $\mathcal{C}^{\cap f}$ denotes the class of all subsets of S which are finite intersections of sets in \mathcal{C} .

PROOF OF THE CT \mathcal{L} -C 2.3.9 (carried out in three steps).

Assume (2.3.11) and (2.3.12).

STEP 1: According to (2.3.11) there exists a countable and d -dense subset D of T . We are going to show:

There exists a stochastic process $\eta_0 = (\eta_0(t))_{t \in T}$ with sample paths in $S_0 \equiv U^b(T, d)$ such that

$$\eta_{0,D} \stackrel{\mathcal{L}}{\underset{\text{fidi}}{=}} \bar{\eta}_{0,D}, \quad \text{where } \eta_{0,D} := (\eta_0(t))_{t \in D} \quad \text{and} \quad \bar{\eta}_{0,D} = (\bar{\eta}_0(t))_{t \in D}.$$

For this, let $U(D, d) := \{x : D \rightarrow \mathbb{R} : x \text{ uniformly } d\text{-continuous}\}$. Then it suffices to show that

$$(a) \quad \text{there exists a stochastic process } \eta_{0,D} := (\eta_0(t))_{t \in D} \text{ on some proper p-space } (\Omega_0, \mathcal{A}_0, \mathbb{P}_0) \text{ with sample paths in } U(D, d) \text{ such that } \eta_{0,D} \stackrel{\mathcal{L}}{\underset{\text{fidi}}{=}} \bar{\eta}_{0,D}.$$

In fact, once (a) is shown, we can define for each $\omega \in \Omega_0$ $\eta_0(\omega)$ as the uniquely determined uniformly d -continuous extension on T of $\eta_{0,D}(\omega)$ being also bounded since T is totally bounded, whence $\eta_0(\omega) \in U^b(T, d)$ for each $\omega \in \Omega_0$.

Now, verifying (a) is equivalent (cf. [Gae77], 7.2.31 and 7.1.18) with proving

$$(b) \quad P_{\bar{\eta}_0}(\bar{\eta}_{0,D} \in U(D, d)) = 1, \quad \text{where } P_{\bar{\eta}_0} := \mathcal{L}\{\bar{\eta}_0\}.$$

For this, let $D = \{t_1, t_2, \dots\}$; then

$$\begin{aligned} & P_{\bar{\eta}_0}(\bar{\eta}_{0,D} \in U(D, d)) \\ &= P_{\bar{\eta}_0}\left(\forall \varepsilon > 0 \exists \delta > 0 \forall t, t' \in D : d(t, t') \leq \delta \implies |\bar{\eta}_0(t) - \bar{\eta}_0(t')| \leq \varepsilon\right) \\ &= P_{\bar{\eta}_0}\left(\forall \varepsilon > 0 \exists \delta > 0 \forall m \in \mathbb{N} \forall 1 \leq i, j \leq m : d(t_i, t_j) \leq \delta \implies |\bar{\eta}_0(t_i) - \bar{\eta}_0(t_j)| \leq \varepsilon\right) \\ &= P_{\bar{\eta}_0}\left(\forall \varepsilon > 0 \exists \delta > 0 \forall m \in \mathbb{N} \forall 1 \leq i, j \leq m : (\bar{\eta}_0(t_1), \dots, \bar{\eta}_0(t_m)) \in F_{ij}(\varepsilon, \delta, m)\right), \end{aligned}$$

where

$$F_{ij}(\varepsilon, \delta, m) := \begin{cases} \mathbb{R}^m, & \text{if } d(t_i, t_j) > \delta \\ \{(r_1, \dots, r_m) \in \mathbb{R}^m : |r_i - r_j| \leq \varepsilon\}, & \text{if } d(t_i, t_j) \leq \delta. \end{cases}$$

By the way, since the F_{ij} 's are closed and since we may restrict ourselves to rational ε 's and δ 's, this shows that $\{\bar{\eta}_{0,D} \in U(D, d)\}$ is measurable.

Furthermore, by σ -continuity of $P_{\bar{\eta}_0}$

$$\begin{aligned} & P_{\bar{\eta}_0}(\bar{\eta}_{0,D} \in U(D, d)) = \\ & \lim_{\varepsilon \rightarrow 0} \lim_{\delta \rightarrow 0} \lim_{m \rightarrow \infty} P_{\bar{\eta}_0}\left((\bar{\eta}_0(t_1), \dots, \bar{\eta}_0(t_m)) \in \bigcap_{1 \leq i, j \leq m} F_{ij}(\varepsilon, \delta, m)\right) \geq \\ (+) \quad & \lim_{\varepsilon \rightarrow 0} \lim_{\delta \rightarrow 0} \lim_{m \rightarrow \infty} \limsup_{n \rightarrow \infty} \mathbb{P}\left((\eta_n(t_1), \dots, \eta_n(t_m)) \in \bigcap_{1 \leq i, j \leq m} F_{ij}(\varepsilon, \delta, m)\right), \end{aligned}$$

where the inequality follows by (2.3.10) and the classical Portmanteau-Theorem ([Bi68], Theorem 2.1 with $S = \mathbb{R}^m$); furthermore,

$$\begin{aligned} (+) \quad & \geq \lim_{\varepsilon \rightarrow 0} \lim_{\delta \rightarrow 0} \limsup_{n \rightarrow \infty} \mathbb{P}^*\left(\forall t, t' \in T : d(t, t') \leq \delta \implies |\eta_n(t) - \eta_n(t')| \leq \varepsilon\right) \\ &= \lim_{\varepsilon \rightarrow 0} \lim_{\delta \rightarrow 0} \limsup_{n \rightarrow \infty} \mathbb{P}^*(w_{\eta_n}(\delta) \leq \varepsilon) \stackrel{(2.3.12)}{=} 1. \end{aligned}$$

The proof of the following step is due to Franz Strobl ([St94], Thm. 2.1).

STEP 2: Using the auxiliary lemma from above, we are going to show now

$$(2.3.13) \quad \eta_n \xrightarrow[\text{sep}]{\mathcal{L}} \eta_0, \quad \text{where w.l.o.g } \eta_0 \text{ is assumed to be also defined on our basic p-space } (\Omega, \mathcal{A}, \mathbb{P}) \text{ properly enlarged.}$$

Since (by (2.3.11)), $S_0 = U^b(T, d)$ is a separable and closed subspace of $(S, s) = (l^\infty(T), \|\cdot\|_T)$ (cf. [Gae90], Corollary 2), we can apply the auxiliary lemma. For this, let

$$\mathcal{C} := \{B(x, r) : x \in S_0, r > 0, \mathbb{P}(\eta_0 \in \partial B(x, r)) = 0\},$$

where $B(x, r) := \{y \in S : \|y - x\|_T \leq r\}$. Then one easily verifies

$$(\star) \quad \forall G \text{ open } \subset S \text{ and } \forall x \in G \cap S_0^c = G \cap S_0 \exists C_x \in \mathcal{C} \text{ s.t. } x \in C_x^0 \subset C_x \subset G.$$

Therefore, to verify (2.3.13) it remains to show

$$(c) \quad \limsup \mathbb{P}^*(\eta_n \in C) \leq \mathbb{P}(\eta_0 \in C) \quad \text{and}$$

$$(d) \quad \liminf \mathbb{P}_*(\eta_n \in C) \geq \mathbb{P}(\eta_0 \in C) \quad \text{for all } C \in \mathcal{C}^{\cap f} = \{\bigcap_{i \leq n} C_i : n \in \mathbb{N}, C_i \in \mathcal{C}, 1 \leq i \leq n\}.$$

Now, given any $C \in \mathcal{C}^{\cap f}$ one can choose appropriate $g, h \in U^b(T, d)$ such that C can be represented as

$$C = \{y \in S : g(t) \leq y(t) \leq h(t) \quad \forall t \in T\}.$$

(If $C = B(x, r)$, choose $g := x - r$ and $h := x + r$; in case of finite intersections of balls $B(x_i, r_i)$ one has to choose maxima and minima of such g_i 's and h_i 's, respectively.)

Next, given $C = \bigcap_{i \leq n} B(x_i, r_i) = \{y \in S : g \leq y \leq h\}$ and an arbitrary $\varepsilon > 0$, choose $\lambda = \lambda(\varepsilon) > 0$ s.t. with $C_\lambda := \{y \in S : g + \lambda \leq y \leq h - \lambda\}$

$$(e) \quad \mathbb{P}(\eta_0 \in C) \leq \mathbb{P}(\eta_0 \in C_{5\lambda/4}) + \varepsilon/2.$$

Before making the next step rigorous, we argue at first informally:

By the AEC (2.3.12) one can choose $\delta > 0$ s.t. for n large enough up to probability $\varepsilon/2$ the oscillation of η_n within span δ is at most $\lambda/2$ and this is also true for g and h (due to their uniform continuity). Since T is totally bounded, we can choose a δ -net $\{t_1, \dots, t_m\} \subset T$ (which means that for each $t \in T$ there is a t_i with $d(t, t_i) < \delta$); since the oscillations of g, h and η_n (up to probability $\varepsilon/2$) within $V(t_i) := \{t \in T : d(t, t_i) < \delta\}$ are at most $\lambda/2$, we get

$$(f) \quad \mathbb{P}(\forall i : g(t_i) + \lambda < \eta_n(t_i) < h(t_i) - \lambda) \leq \mathbb{P}_*(\eta_n \in C) + \varepsilon/2,$$

whence by fidi-convergence we obtain (d):

$$\begin{aligned} \mathbb{P}(\eta_0 \in C) &\stackrel{(e)}{\leq} \mathbb{P}(\eta_0 \in C_{5\lambda/4}) + \varepsilon/2 \leq \mathbb{P}(\forall i : g(t_i) + \lambda < \eta_0(t_i) < h(t_i) - \lambda) + \varepsilon/2 \\ &\stackrel{(f)}{\leq} \liminf_{n \rightarrow \infty} \mathbb{P}(\forall i : g(t_i) + \lambda < \eta_n(t_i) < h(t_i) - \lambda) + \varepsilon/2 \\ &\stackrel{(f)}{\leq} \mathbb{P}_*(\eta_n \in C) + \varepsilon/2. \end{aligned}$$

Now, making the above reasoning rigorous, note first that $C_\lambda \uparrow C^0$ as $\lambda \downarrow 0$ and $\mathbb{P}(\eta_0 \in \partial C) = 0$ implies that for each $\varepsilon > 0$ there exists a $\lambda = \lambda(\varepsilon) > 0$ s.t. (e) holds true.

Since $\mathbb{P}(\eta_0 \in U^b(T, d)) = 1$, there exists a $\delta = \delta(\varepsilon) > 0$ s.t. $\mathbb{P}(\eta_0 \in H) \geq 1 - \frac{\varepsilon}{2}$, where

$$H := \{y \in S : \sup_{t, t' \in T, d(t, t') < \delta} |y(t) - y(t')| \leq \lambda/2\}.$$

By (2.3.12), choosing δ small enough, we have in addition that

$$\limsup_{n \rightarrow \infty} \mathbb{P}^*(\eta_n \in \mathfrak{C}H) < \varepsilon/2 \quad (\mathfrak{C}H \equiv \mathbb{R}^T \setminus H).$$

Since $g, h \in U^b(T, d)$, we may also assume that $g, h \in H$ (again by choosing δ small enough).

Now, let $D = \{t_1, t_2, \dots\}$ be as above and $m \in \mathbb{N}$ large enough s.t. $T = \bigcup_{i \leq m} V(t_i, \delta)$ with $V(t_i, \delta) := \{t \in T : d(t, t_i) < \delta\}$ (such an m exists by (2.3.11) and since D is d -dense in T).

Then, for any $x \in H$ and $t \in T$ we have the following implications (choosing $i \in \{1, \dots, m\}$ s.t. $d(t, t_i) < \delta$):

$$\begin{aligned} x(t_i) < h(t_i) - \lambda &\implies x(t) \underset{(x \in H)}{\leq} x(t_i) + \lambda/2 < h(t_i) - \lambda/2 \underset{(h \in H)}{\leq} h(t), \quad \text{and} \\ x(t_i) > g(t_i) + \lambda &\implies x(t) \underset{(x \in H)}{\geq} x(t_i) - \lambda/2 > g(t_i) + \lambda/2 \underset{(g \in H)}{\geq} g(t). \end{aligned}$$

Thus,

$$\{\eta_n \in H \text{ and } g(t_i) + \lambda < \eta_n(t_i) < h(t_i) - \lambda \ \forall 1 \leq i \leq m\} \subset \{\eta_n \in C\},$$

and therefore

$$\begin{aligned} \mathbb{P}_*(\eta_n \in C) &\geq \mathbb{P}_*\left(\{\eta_n \in H\} \cap \{g(t_i) + \lambda < \eta_n(t_i) < h(t_i) - \lambda \ \forall 1 \leq i \leq m\}\right) \\ &= 1 - \mathbb{P}^*\left(\{\eta_n \in \mathfrak{C}H\} \cup \mathfrak{C}\{g(t_i) + \lambda < \eta_n(t_i) < h(t_i) - \lambda \ \forall 1 \leq i \leq m\}\right) \\ &\geq 1 - \mathbb{P}^*(\eta_n \in \mathfrak{C}H) - \mathbb{P}^*\left(\mathfrak{C}\{g(t_i) + \lambda < \eta_n(t_i) < h(t_i) - \lambda \ \forall 1 \leq i \leq m\}\right) \\ &= \underbrace{\mathbb{P}_*\left(g(t_i) + \lambda < \eta_n(t_i) < h(t_i) - \lambda \ \forall 1 \leq i \leq m\right)}_{= \mathbb{P}((\eta_n(t_1), \dots, \eta_n(t_m)) \in G), \text{ where}} - \mathbb{P}^*(\eta_n \in \mathfrak{C}H) \end{aligned}$$

$G := \{(r_1, \dots, r_m) \in \mathbb{R}^m : g(t_i) + \lambda < r_i < h(t_i) - \lambda \ \forall 1 \leq i \leq m\}$ is an open subset of \mathbb{R}^m .

Thus, (2.3.10) and the classical Portmanteau-Theorem together with STEP 1 (according to which $\eta_{0,D} \xrightarrow[\text{fidi}]{\mathcal{L}} \bar{\eta}_{0,D}$) imply

$$\begin{aligned} \liminf_{n \rightarrow \infty} \mathbb{P}_*(\eta_n \in C) &\geq \liminf_{n \rightarrow \infty} \mathbb{P}((\eta_n(t_1), \dots, \eta_n(t_m)) \in G) - \limsup_{n \rightarrow \infty} \mathbb{P}^*(\eta_n \in \mathfrak{C}H) \\ &> \mathbb{P}((\eta_0(t_1), \dots, \eta_0(t_m)) \in G) - \varepsilon/2 \\ &= \mathbb{P}\left(g(t_i) + \lambda < \eta_0(t_i) < h(t_i) - \lambda \ \forall 1 \leq i \leq m\right) - \varepsilon/2 \\ &\geq \mathbb{P}(\eta_0 \in C_{5\lambda/4}) - \varepsilon/2 \underset{(\varepsilon)}{>} \mathbb{P}(\eta_0 \in C) - \varepsilon. \end{aligned}$$

Since $\varepsilon > 0$ was chosen arbitrary, (d) is shown.

As to (c), the proof runs quite similarly: For $\lambda > 0$ let

$$C^\lambda := \{y \in S : g(y) - \lambda \leq y(t) \leq h(t) + \lambda \ \forall t \in T\}.$$

Since $C^\lambda \downarrow C$ as $\lambda \downarrow 0$, we can choose $\forall \varepsilon > 0$ a $\lambda = \lambda(\varepsilon) > 0$ s.t.

$$\mathbb{P}(\eta_0 \in C^\lambda) \leq \mathbb{P}(\eta_0 \in C) + \varepsilon/2.$$

Let H, δ and m be as before. Then, analogously, for $x \in H, t \in T$ and $i \in \{1, \dots, m\}$ with $d(t, t_i) < \delta$:

$$\begin{aligned} x(t_i) \leq h(t_i) &\implies x(t) \leq x(t_i) + \lambda/2 \leq h(t_i) + \lambda/2 \leq h(t) + \lambda, \quad \text{and} \\ x(t_i) \geq g(t_i) &\implies x(t) \geq x(t_i) - \lambda/2 \geq g(t_i) - \lambda/2 \geq g(t) - \lambda. \end{aligned}$$

Now, $\mathbb{P}^*(\eta_n \in C) \leq \mathbb{P}^*(g(t_i) \leq \eta_n(t_i) \leq h(t_i) \forall 1 \leq i \leq m) = \mathbb{P}((\eta_n(t_1), \dots, \eta_n(t_m)) \in F)$, where $F := \{(r_1, \dots, r_m) \in \mathbb{R}^m : g(t_i) \leq r_i \leq h(t_i) \forall 1 \leq i \leq m\}$ is a closed subset of \mathbb{R}^m . Thus, as before (2.3.10) and the classical Portmanteau-Theorem together with STEP 1 imply

$$\begin{aligned} \limsup_{n \rightarrow \infty} \mathbb{P}^*(\eta_n \in C) &\leq \mathbb{P}((\eta_0(t_1), \dots, \eta_0(t_m)) \in F) = \mathbb{P}(g(t_i) \leq \eta_0(t_i) \leq h(t_i) \forall 1 \leq i \leq m) \\ &\leq \mathbb{P}(\eta_0 \in \mathbf{C}H) + \mathbb{P}(g(t) - \lambda \leq \eta_0(t) \leq h(t) + \lambda \forall t \in T) \\ &\leq \varepsilon/2 + \mathbb{P}(\eta_0 \in C^\lambda) \leq \mathbb{P}(\eta_0 \in C) + \varepsilon. \end{aligned}$$

Since $\varepsilon > 0$ was chosen arbitrary, also (c) is shown. Thus, (2.3.13) is proved.

It is now easy to verify $\eta_0 \xrightarrow[\text{fidi}]{} \bar{\eta}_0$ using the continuous mapping theorem 2.3.16 below together with (2.3.10).

The proof of the converse part of 2.3.9 is as follows:

STEP 3: (2.3.13) (with $U^b(T, d)$ as a separable subspace of $l^\infty(T)$) implies (2.3.11) (according to [Gae90], Corollary 2). So it remains to show that (2.3.13) implies the AEC (2.3.12):

For this, let $\varepsilon > 0$ and $H(\delta) := \{x \in \mathbb{R}^T : w_x(\delta) \geq \varepsilon\}$, $\delta > 0$; then $H(\delta) \cap S$ is a closed subset of S , and therefore, by Theorem 2.3.14 (ii) below

$$\begin{aligned} \lim_{\delta \rightarrow 0} \limsup_{n \rightarrow \infty} \mathbb{P}^*(w_{\eta_n}(\delta) > \varepsilon) &\leq \\ \lim_{\delta \rightarrow 0} \limsup_{n \rightarrow \infty} \mathbb{P}^*(\eta_n \in H(\delta)) &\leq \lim_{\delta \rightarrow 0} \mathbb{P}(\eta_0 \in H(\delta)) = \\ \lim_{\delta \rightarrow 0} \mathbb{P}\left(\sup_{t, t' \in T, d(t, t') \leq \delta} |\eta_0(t) - \eta_0(t')| \geq \varepsilon\right) &= \quad (\sigma\text{-continuity of } \mathbb{P}) \\ \mathbb{P}(\forall \delta > 0 : \sup_{t, t' \in T, d(t, t') \leq \delta} |\eta_0(t) - \eta_0(t')| \geq \varepsilon) &\leq \mathbb{P}(\eta_0 \notin U^b(T, d)) = 0. \quad \square \end{aligned}$$

REMARK. The just given proof together with 2.3.14 below also shows:

If $\eta_n = (\eta_n(t))_{t \in T}$ with $T = (T, d)$ being totally bounded, $n \in \mathbb{N}$, is a sequence of RANDOM QUANTITIES $\eta_n : \Omega \rightarrow \mathbb{R}^T$ (i.e. with $\eta_n(t), t \in T$, not being necessarily rv's on $(\Omega, \mathcal{A}, \mathbb{P})$), if η_0 is a re in $l^\infty(T)$ with sample paths in $U^b(T, d)$ s.t. $(\eta_n(t_1), \dots, \eta_n(t_m)) \xrightarrow{\mathcal{L}} (\eta_0(t_1), \dots, \eta_0(t_m))$ (in the sense of (2.3.6)) $\forall t_1, \dots, t_m \in D, m \in \mathbb{N}$ (i.e. if the fidi-convergence on D holds true), then (2.3.12) implies (2.3.13) (in the sense of (2.3.6) with $S = l^\infty(T), E = \mathbb{R}^T, S_0 = U^b(T, d)$).

The following theorem is part of the Portmanteau-Theorem needed for our purposes. For a more comprehensive list of equivalent conditions for \mathcal{L} -convergence in our general model (2.3.5) we refer to [St94], Thm. 1.5; cf. also [Va96], Thm. 1.3.4.

2.3.14 THEOREM .

Given the general model (2.3.5), the following assertions are equivalent:

- (i) $\eta_n \xrightarrow{\mathcal{L}} \eta_0$ (in the sense of (2.3.6))
- (ii) $\limsup_{n \rightarrow \infty} \mathbb{P}^*(\eta_n \in H) \leq \mathbb{P}(\eta_0 \in H) \quad \forall H \subset E, H \cap S \text{ closed in } S$
- (ii') $\limsup_{n \rightarrow \infty} \mathbb{P}^*(\eta_n \in F) \leq \mathbb{P}(\eta_0 \in F) \quad \forall F \text{ closed } \subset S$, and $\limsup_{n \rightarrow \infty} \mathbb{P}^*(\eta_n \in E \setminus S) = 0$

(iii) $\liminf_{n \rightarrow \infty} \mathbb{P}_*(\eta_n \in H) \geq \mathbb{P}(\eta_0 \in H) \quad \forall H \subset E, H \cap S \text{ open in } S$

(iii') $\liminf_{n \rightarrow \infty} \mathbb{P}_*(\eta_n \in G) \geq \mathbb{P}(\eta_0 \in G) \quad \forall G \text{ open } \subset S.$

The proof of 2.3.14 is tailored along arguments used to prove the classical Portmanteau-Theorem as in [Bi68].

2.3.15 THEOREM (*Cramér-Slutzky-type result*) ([St94], Thm. 1.16).

Given a basic p -space $(\Omega, \mathcal{A}, \mathbb{P})$, a metric space $S = (S, s)$ and an arbitrary $E \supset S$, let $\eta_n, \zeta_n : \Omega \rightarrow E, n \geq 1$, be r.v.'s and $\eta_0 : \Omega \rightarrow S$ be a r.v. in $(S, \mathcal{B}(S))$ such that

$$(+) \quad \lim_{n \rightarrow \infty} \mathbb{P}_*(\eta_n, \zeta_n \in S \text{ and } s(\eta_n, \zeta_n) \leq \varepsilon) = 1 \quad \forall \varepsilon > 0$$

where $s(\eta_n, \zeta_n)(\omega) := s(\eta_n(\omega), \zeta_n(\omega)), \omega \in \Omega$. Then

$$\eta_n \xrightarrow{\mathcal{L}} \eta_0 \iff \zeta_n \xrightarrow{\mathcal{L}} \eta_0.$$

PROOF. By symmetry, it suffices to show " \implies ": We are going to use the criterion (ii) from 2.3.14. For this, given any $H \subset E$ and $\varepsilon > 0$ s.t. $H \cap S$ is closed in S , the set

$$F := (H \cap S)^\varepsilon := \{x \in S : \inf_{y \in H \cap S} s(x, y) \leq \varepsilon\}$$

is also closed in S , whence

$$\begin{aligned} \limsup_{n \rightarrow \infty} \mathbb{P}^*(\zeta_n \in H) &\leq \limsup_{n \rightarrow \infty} \left[\mathbb{P}^*(\zeta_n \in H, \eta_n, \zeta_n \in S \text{ and } s(\eta_n, \zeta_n) \leq \varepsilon) + \right. \\ &\quad \left. \mathbb{P}^*(\mathbb{C}\{\eta_n, \zeta_n \in S \text{ and } s(\eta_n, \zeta_n) \leq \varepsilon\}) \right] \leq \\ \limsup_{n \rightarrow \infty} \mathbb{P}^*(\eta_n \in F) + 1 - \liminf_{n \rightarrow \infty} \mathbb{P}_*(\eta_n, \zeta_n \in S \text{ and } s(\eta_n, \zeta_n) \leq \varepsilon) &\stackrel{(+)}{=} \\ \limsup_{n \rightarrow \infty} \mathbb{P}^*(\eta_n \in F) &\leq \mathbb{P}(\eta_0 \in F). \end{aligned}$$

2.3.14(ii)

Since $H \cap S$ is closed in S , we have $(H \cap S)^\varepsilon \downarrow H \cap S$ as $\varepsilon \downarrow 0$, whence for $\varepsilon \downarrow 0$

$$\mathbb{P}(\eta_0 \in F) \downarrow \mathbb{P}(\eta_0 \in H \cap S) = \mathbb{P}(\eta_0 \in H),$$

and therefore

$$\limsup_{n \rightarrow \infty} \mathbb{P}^*(\zeta_n \in H) \leq \mathbb{P}(\eta_0 \in H)$$

from which $\zeta_n \xrightarrow{\mathcal{L}} \eta_0$ follows according to 2.3.14(ii). □

2.3.16 THEOREM (*Continuous Mapping Theorem (CMT)*) ([St94], Thm. 1.8; cf. also [Va96], Thm. 1.3.6).

In addition to our general model (2.3.5), let $S' = (S', s')$ be a further metric space and E' be arbitrary, $E' \supset S'$. Let $g : E \rightarrow E'$ be a given map with $g(S) \subset S'$ and let $S_g \in \mathcal{B}(S)$ be such that $\text{rest}_{S_g} g$ is continuous at every point in S_g ; then, assuming in addition that η_0 takes its values in S_g , $\eta_n \xrightarrow{\mathcal{L}} \eta_0$ implies $g \circ \eta_n \xrightarrow{\mathcal{L}} g \circ \eta_0$.

In connection with RANDOM QUANTITIES (rq's) $\zeta : \Omega \longrightarrow \overline{\mathbb{R}} := \mathbb{R} \cup \{\pm\infty\}$ (being not necessarily rv's) the following concept and its consequences turn out to be useful at some places later on; cf. [Va96], Lemma 1.2.1 and Lemma 1.2.2; cf. also the Notes on p. 75 in [Va96] referring to early papers by Blumberg in 1935 and by Eames and May in 1967.

- (2.3.17) Let $(\Omega, \mathcal{A}, \mathbb{P})$ be a p-space and $\zeta : \Omega \longrightarrow \overline{\mathbb{R}}$ be a rq. Then there exists a measurable function $\zeta^* : \Omega \longrightarrow \overline{\mathbb{R}}$ with
- (i) $\zeta^* \geq \zeta$, and
 - (ii) $\zeta^* \leq \eta$ $\mathbb{P} - a.s \forall$ measurable $\eta : \Omega \longrightarrow \overline{\mathbb{R}}$ with $\eta \geq \zeta$ $\mathbb{P} - a.s.$

ζ^* is $\mathbb{P} - a.s.$ uniquely determined and for any ζ^* fulfilling (i) and (ii), it holds that $\mathbb{E}^*(\zeta) = \mathbb{E}(\zeta^*)$, provided $\mathbb{E}(\zeta^*)$ exists; the latter is certainly true if $\mathbb{E}^*(\zeta) < \infty$; furthermore one has $\mathbb{P}^*(\zeta > t) = \mathbb{P}(\zeta^* > t) \quad \forall t \in \mathbb{R}$.

The function ζ^* is called minimal measurable majorant of ζ , or also called MEASURABLE COVER or ENVELOPE FUNCTION.

Before concluding this section, let us have once more a glance onto the Characterization Theorem 2.3.9:

As already remarked there, the condition (2.3.10) will be fulfilled in most cases due to classical multivariate CLT's. Also, (2.3.11) will be fulfilled by choosing the pseudo-metric d appropriately; e.g. in the case $T = \mathcal{C}, \mathcal{C} \subset \mathcal{X}$ a VCC, let $d := d_\nu, \nu$ being an arbitrary p-measure on \mathcal{X} ; then the condition (2.3.11) holds as we shall see in section 4.2.

So, in order to prove (2.3.13), the crucial task is to verify the AEC (2.3.12):

Since Markov's inequality also holds in the case of outer probabilities and outer expectations, respectively, for verifying the AEC it suffices to show

$$(2.3.18) \quad \lim_{\delta \rightarrow 0} \limsup_{n \rightarrow \infty} \mathbb{E}^* \left(\sup_{t, t' \in T, d(t, t') \leq \delta} |\eta_n(t) - \eta_n(t')| \right) = 0,$$

i.e. later on we will have at our disposal the following fact:

2.3.19 REMARK.

The conditions (2.3.10), (2.3.11) and (2.3.18) imply (2.3.13), i.e. $\eta_n \xrightarrow[\text{sep}]{\mathcal{L}} \eta_0$, where η_0 has all its sample paths in $U^b(T, d)$ and where $\eta_0 \stackrel{\mathcal{L}}{\underset{\text{fidi}}{=}} \overline{\eta}_0$.

2.3.19 (with (2.3.18) instead of the AEC (2.3.12)) leads to essential simplifications in proving FCLT's in section 7 comparable with the role of (2.1.5) in proving ULLN's.

3 Random Measures Processes (RMP's)

3.1 Empirical Processes, partial-sum processes and smoothed empirical processes, respectively, considered as special cases of RMP's

In order to cope in later sections also with processes indexed by classes of functions instead of sets (cf. section 4.3 for some motivation) the general context will be now as follows:

Let $X = (X, \mathcal{X})$ be an arbitrary measurable space (sample space) and \mathcal{F} be a class of \mathcal{X} -measurable functions $f : X \rightarrow \mathbb{R}$ with \mathcal{X} -measurable envelope $F : X \rightarrow \mathbb{R}_+$ (i.e. $\sup_{f \in \mathcal{F}} |f(x)| \leq F(x) \quad \forall x \in X$). Let $(w_{nj})_{1 \leq j \leq j(n), n \in \mathbb{N}}$ be a triangular array of p-measures on \mathcal{X} and $(\xi_{nj})_{1 \leq j \leq j(n), n \in \mathbb{N}}$ be a triangular array of real-valued rv's.

Random Measure Processes (RMP's) $S_n = (S_n(f))_{f \in \mathcal{F}}$ (of sample size n) (indexed by \mathcal{F}) are defined by

$$(3.1.1) \quad S_n(f) := \sum_{j \leq j(n)} w_{nj}(f) \cdot \xi_{nj}, \quad f \in \mathcal{F},$$

where $w_{nj}(f) := \int_X f d w_{nj}$.

We tacitly assume regularity conditions such as measurability and finiteness of $w_{nj}(F)$ (which implies that the sample paths of S_n are contained in the Banach space

$$l^\infty(\mathcal{F}) := \{x : \mathcal{F} \rightarrow \mathbb{R} : \|x\|_{\mathcal{F}} := \sup_{f \in \mathcal{F}} |x(f)| < \infty\},$$

endowed with the sup-norm $\|\cdot\|_{\mathcal{F}}$.

In connection with Uniform Laws of Large Numbers (ULLN) and Functional Central Limit Theorems (FCLT) in section 6 and 7, respectively, it will be assumed that $j(n) \rightarrow \infty$ as $n \rightarrow \infty$ and that

for all $n \in \mathbb{N}$ the sequence of pairs
 $(w_{n1}, \xi_{n1}), \dots, (w_{nj(n)}, \xi_{nj(n)})$ is independent.

(Here independence is to be understood in the sense of independence of the rq's $(w_{nj}(f) \cdot \xi_{nj})_{f \in \mathcal{F}}, 1 \leq j \leq j(n)$, for each n , which means that $(w_{nj}(f) \cdot \xi_{nj})_{f \in \mathcal{F}}, 1 \leq j \leq j(n), n \in \mathbb{N}$, are considered as coordinate projections on an appropriately chosen product-p-space $(\Omega, \mathcal{A}, \mathbb{P})$ (cf. Section 5.1 for the definition of independence of rq's and also section 6.1 below).

However, we do not assume that the above pairs are identically distributed; also dependence within each pair is allowed.

Processes of the form (3.1.1) with $\mathcal{F} = \{1_C : C \in \mathcal{C}\}, \mathcal{C} \subset \mathcal{X}$, and *non-random* p-measures w_{nj} , were first considered in [Al87] and in its present general form in [Zi94] (see also [Va96], Section 2.12.2 for closely related examples).

Now, special cases of RMP's occur when considering

- the classical multivariate partial-sum process of section 1.3 and 1.4 where $X = I^d$, $d \geq 1$, $w_{nj} = \delta_{j/n}$, $\xi_{nj} := n^{-d/2} \xi_{\underline{j}}$, $\underline{j} \in \{1, \dots, n\}^d$, and $\mathcal{F} = \{1_C : C \in \mathcal{C}\}$ with $\mathcal{C} = \{[0, \underline{t}] : \underline{t} \in I^d\}$;
- empirical processes indexed by \mathcal{F} given by $\nu_n(f) := j(n)^{-1} \sum_{j \leq j(n)} f(\eta_{nj})$, $f \in \mathcal{F}$, based on re's η_{nj} in (X, \mathcal{X}) , where $w_{nj} = \delta_{\eta_{nj}}$ and $\xi_{nj} \equiv j(n)^{-1}$;
- smoothed empirical processes:

Here X is assumed to be a linear metric space endowed with its Borel σ -field \mathcal{X} . Let η_j , $j \in \mathbb{N}$, be iid re's in (X, \mathcal{X}) with law ν on \mathcal{X} and ν_n be the empirical measure based on η_1, \dots, η_n , i.e. $\nu_n = \sum_{j \leq n} \delta_{\eta_j}$. Now, if ν is “smooth” (one may think of random vectors η_j in $X = \mathbb{R}^d$ whose df has a continuous or even differentiable density w.r.t. Lebesgue measure), it is natural to replace ν_n by a smoothed version $\tilde{\nu}_n$ serving as an estimator for an unknown ν .

As in [Yu89] we will consider “smoothing through convolution” as explained in section 6.4 below. As we will see there, this leads to $\tilde{\nu}_n = (\tilde{\nu}_n(f))_{f \in \mathcal{F}}$ which can be represented as RMP's with $w_{nj}(B) = \mu_n(B - \eta_j)$, $B \in \mathcal{X}$, and $\xi_{nj} \equiv n^{-1}$, where $(\mu_n)_{n \in \mathbb{N}}$ is a given sequence of p-measures μ_n on \mathcal{X} with $\mu_n \rightarrow \delta_0$ weakly (in the sense of weak convergence of Borel measures as in [Bi68]).

3.2 Further Examples

3.2.1 Partial-sum processes with random locations

Let $X = (X, \mathcal{X})$ be an arbitrary measurable space, $\mathcal{C} \subset \mathcal{X}$, $(\eta_{nj})_{1 \leq j \leq j(n), n \in \mathbb{N}}$ be a triangular array of re's in (X, \mathcal{X}) and $(\xi_{nj})_{1 \leq j \leq j(n), n \in \mathbb{N}}$ be a triangular array of real-valued rv's.

PARTIAL-SUM PROCESSES $S_n = (S_n(C))_{C \in \mathcal{C}}$ WITH RANDOM LOCATIONS are defined by

$$(3.2.2) \quad S_n(C) := \sum_{j \leq j(n)} 1_C(\eta_{nj}) \cdot \xi_{nj}, \quad C \in \mathcal{C}.$$

These processes were studied in [Ar92], [Gae94] and [Gae94b], being special RMP's with $\mathcal{F} = \{1_C : C \in \mathcal{C}\}$ and $w_{nj} = \delta_{\eta_{nj}}$.

Many examples of natural phenomena like mineral deposits, earthquakes, forest disease, etc. can be modelled by such processes.

3.2.3 The sequential uniform empirical process

(Cf. [Sh86], Chapter 3.5).

Let η_j , $j \in \mathbb{N}$, be iid rv's with $\mathcal{L}\{\eta_j\} = U[0, 1]$ (as in 1.1). The SEQUENTIAL UNIFORM EMPIRICAL PROCESS (of sample size n) $K_n = (K_n(s, t))_{(s, t) \in I^2}$ based on η_1, \dots, η_n is defined by

$$K_n(s, t) := n^{-1/2} \sum_{j \leq \langle ns \rangle} \left(1_{[0, t]}(\eta_j) - t \right), \quad (s, t) \in I^2.$$

Choosing $X := I^2$, $\mathcal{X} := I^2 \cap \mathcal{B}^2$, $\mathcal{C} := \{[0, s] \times [0, t] : (s, t) \in I^2\}$, $\eta_{nj} := (j/n, \eta_j)$, $1 \leq j \leq j(n) := n$,

and $S_n(C) := n^{-1/2} \sum_{j \leq n} \delta_{\eta_{nj}}(C)$, $C \in \mathcal{C}$, we get for $C = [0, s] \times [0, t]$

$$S_n(C) = n^{-1/2} \sum_{j \leq n} 1_C((j/n, \eta_j)) = n^{-1/2} \sum_{j \leq \langle ns \rangle} 1_{[0, t]}(\eta_j)$$

and $\mathbb{E}(S_n(C)) = n^{-1/2} \sum_{j \leq n} \mathbb{P}(\eta_{nj} \in C) = n^{-1/2} \sum_{j \leq n} \mathbb{P}(\frac{j}{n} \leq s, \eta_j \in [0, t]) = n^{-1/2} \sum_{j \leq \langle ns \rangle} \mathbb{P}(\eta_j \in [0, t]) = n^{-1/2} \langle ns \rangle \cdot t$, whence $S_n(C) - \mathbb{E}(S_n(C)) = K_n(s, t)$, i.e. K_n can be represented as a centered RMP (with $w_{nj} = \delta_{\eta_{nj}}$ and $\xi_{nj} = n^{-1/2}$) indexed by the VCC \mathcal{C} .

If one considers instead of K_n the underlying df

$$G_n(s, t) := n^{-1} \sum_{j \leq \langle ns \rangle} 1_{[0, t]}(\eta_j), \quad (s, t) \in I^2,$$

(in comparison with the edf $F_n(t) = n^{-1} \sum_{j \leq n} 1_{[0, t]}(\eta_j)$, $t \in I$), then, through the additional parameter s it is possible to visualize the appearance of the data y_1, \dots, y_n ($y_j = \eta_j(\omega)$) successively, (therefore the notion “sequential” uniform empirical process) as the following picture may illustrate.

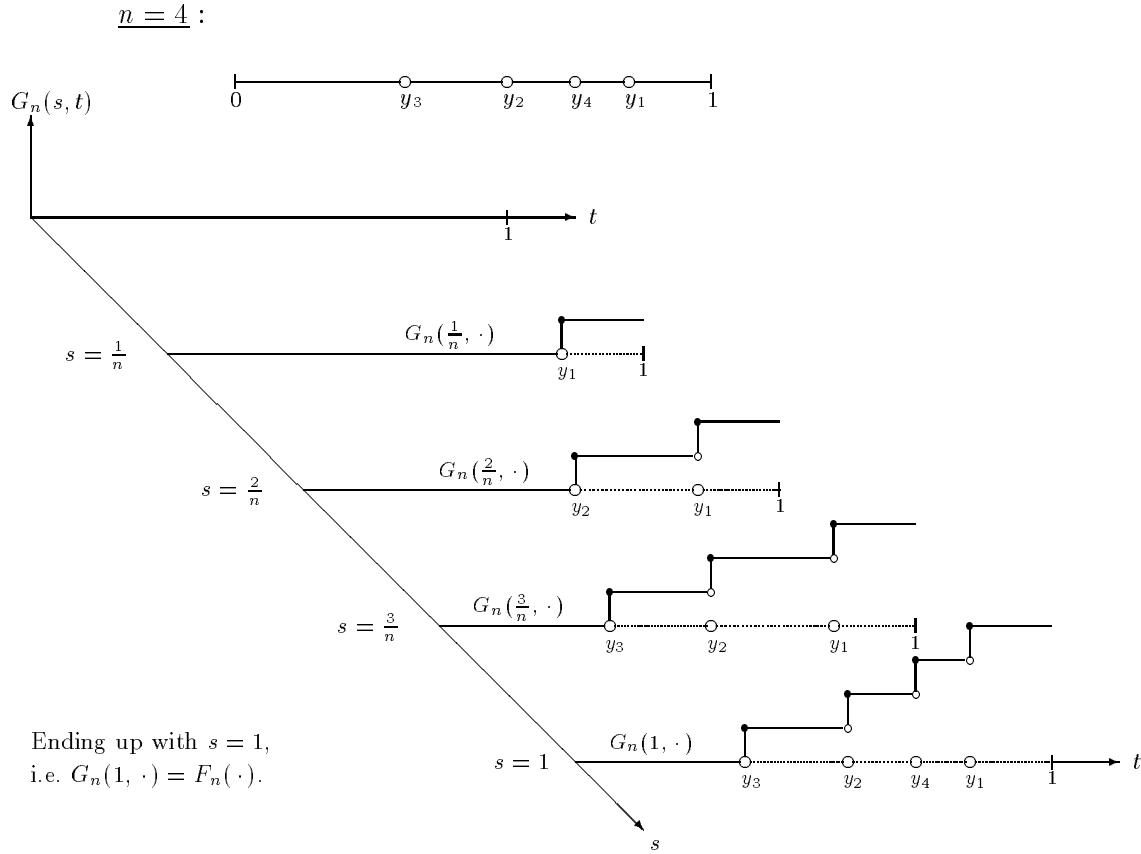

As to the function-indexed sequential empirical process (based on an iid sequence of re's in an arbitrary sample space (X, \mathcal{X}) we refer to [Va96], Section 2.12.1 and to [Zi97], Section 7.4; as in the uniform case, also this process can be represented as a centered RMP.

3.2.4 Nonparametric Regression

(Cf. [Stu97]). Let η be a re in an arbitrary measurable space (X, \mathcal{X}) with law $\mathcal{L}\{\eta\} = \nu$ and let $\mathcal{C} \subset \mathcal{X}$. Let ξ be a rv (defined on the same p-space $(\Omega, \mathcal{A}, \mathbb{P})$ as η) such that $\mathbb{E}(|\xi|) < \infty$. Consider the *regression function*

$$m(y) := \mathbb{E}(\xi|\eta = y), \quad y \in X,$$

and the corresponding *integrated regression function* indexed by \mathcal{C} :

$$\mathbb{I}(C) := \int_C m(y) \nu(dy), \quad C \in \mathcal{C}.$$

Since m is usually ν -a.s. uniquely determined by \mathbb{I} , statistical inference may be based on \mathbb{I} instead of m as well.

Now, $\mathbb{I}(C) = \mathbb{E}(1_C(\eta)\mathbb{E}(\xi|\eta)) = \mathbb{E}(\mathbb{E}(1_C(\eta)\xi|\eta)) = \mathbb{E}(1_C(\eta) \cdot \xi)$, whose empirical version (of sample size n) based on iid pairs (η_j, ξ_j) of re's in $(X \times \mathbb{R}, \mathcal{X} \otimes \mathcal{B})$ (where $\mathcal{L}\{\eta_j\} = \nu$ and $\mathcal{L}\{\xi_j\} = \mathcal{L}\{\xi\}$) is given by

$$\mathbb{I}_n(C) := n^{-1} \sum_{j \leq n} 1_C(\eta_j) \xi_j, \quad C \in \mathcal{C},$$

where $\mathbb{E}(\mathbb{I}_n(C)) = \mathbb{I}(C)$ for all $C \in \mathcal{C}$. Thus \mathbb{I}_n is a RMP indexed by \mathcal{C} (with $w_{nj} \equiv \delta_{\eta_j}$ and $\xi_{nj} = n^{-1}\xi_j$).

At this place we may also mention another paper by Stute et al. ([Stu98]) where (in our notation) processes R_n of the following form are considered:

$$R_n(C) = n^{-1/2} \sum_{j \leq n} 1_C(\eta_j) (\xi_j - m(\eta_j))$$

based on iid re's (η_j, ξ_j) in $(\mathbb{R}^d \times \mathbb{R}, \mathcal{B}^d \otimes \mathcal{B})$ with $C \in \mathcal{C} := \{(-\infty, \underline{y}] : \underline{y} \in \mathbb{R}^d\}$, whence R_n is also a RMP indexed by the VCC \mathcal{C} .

3.2.5 Estimation of Intensity Measures for Spatial Poisson Processes

This example is taken from [Zi97], Section 7.8; cf. also [Li90].

Let Φ be a Poisson point process on an arbitrary state space (X, \mathcal{X}) with finite intensity measure Λ on \mathcal{X} , i.e. (based on an underlying p-space $(\Omega, \mathcal{A}, \mathbb{P})$) $\Phi(\omega, \cdot)$ is a measure on \mathcal{X} with values in $\{0, 1, 2, \dots\}$ for every fixed $\omega \in \Omega$, $\Phi(\cdot, B)$ is a Poisson rv with parameter $\Lambda(B)$ for every fixed $B \in \mathcal{X}$, and for any disjoint $B_1, \dots, B_n \in \mathcal{X}$, $n \in \mathbb{N}$, the rv's $\Phi(\cdot, B_1), \dots, \Phi(\cdot, B_n)$ are independent.

In estimating an unknown intensity measure Λ on the basis of an iid sequence $(\Phi_j)_{j \in \mathbb{N}}$ of Poisson point processes Φ_j (with intensity measure Λ) a natural sequence of estimators $\hat{\Lambda}_n, n \in \mathbb{N}$, is $\hat{\Lambda}_n := n^{-1} \sum_{j \leq n} \Phi_j$ leading to the corresponding standardized process

$$Z_n(f) := n^{1/2}(\hat{\Lambda}_n(f) - \Lambda(f)), \quad f \in \mathcal{F},$$

in view of a FCLT for $Z_n = (Z_n(f))_{f \in \mathcal{F}}$, where \mathcal{F} is an appropriate class of measurable functions $f : X \rightarrow \mathbb{R}$ with $f \in \mathcal{L}_2(X, \mathcal{X}, \Lambda)$; note that $\mathbb{E}(\Phi(f)) = \Lambda(f)$ for all f .

Now, since $Z_n(f) = n^{-1/2} \sum_{j \leq n} (\Phi_j(f) - \mathbb{E}(\Phi_j(f))) = S_n(f) - \mathbb{E}(S_n(f))$ with $S_n(f) := \sum_{j \leq n} w_{nj}(f) \cdot \xi_{nj}$, where $w_{nj} := \Phi_j / \Phi_j(X)$ and $\xi_{nj} := n^{-1/2} \Phi_j(X)$, Z_n can be considered as a RMP indexed by \mathcal{F} to which our result in section 7.1 will apply.

3.2.6 Lévy's Multivariate Brownian motion as a set-indexed process and as limiting process of a sequence of Partial-sum processes with random locations

We will follow here the exposition presented in the paper by Mina Ossiander and Ronald Pyke [Os85]:

Let $B = (B(t))_{t \in \mathbb{R}_+}$ be a Brownian motion (indexed by the parameter space $T = \mathbb{R}_+$), i.e. a mean-zero Gaussian process with independent and stationary increments whose covariance function is given by

$$(1) \quad \text{cov}(B(s), B(t)) = s \wedge t, \quad s, t \in \mathbb{R}_+$$

or equivalently, since $s \wedge t = (|t| + |s| - |t - s|)/2$, by

$$(2) \quad \text{cov}(B(s), B(t)) = (|t| + |s| - |t - s|)/2, \quad s, t \in \mathbb{R}_+.$$

Now, in view of (2) Lévy's multivariate Brownian motion ([Lé40], [Lé45]) is defined to be a mean-zero Gaussian process (*random field*) $Z = (Z(\underline{t}))_{\underline{t} \in \mathbb{R}^d}$ with

$$(3) \quad \text{cov}(Z(\underline{s}), Z(\underline{t})) = (|\underline{t}| + |\underline{s}| - |\underline{t} - \underline{s}|)/2, \quad \underline{s}, \underline{t} \in \mathbb{R}^d,$$

where $|\cdot|$ is the Euclidian norm in \mathbb{R}^d , $d \geq 1$.

The covariance structure (3) can also be characterized by the isotropic mean square condition

$$(4) \quad \mathbb{E}((Z(\underline{s}) - Z(\underline{t}))^2) = |\underline{t} - \underline{s}|, \quad \underline{s}, \underline{t} \in \mathbb{R}^d.$$

Notice that $Z(\underline{s})$ and $Z(\underline{t}) - Z(\underline{s})$ are independent if and only if $0, \underline{s}$ and \underline{t} are colinear, so that the independent increments property of one-dimensional Brownian motion has apparently not been fully generalized.

A second generalization of Brownian motion to multi-dimensional time was given by Chentsov ([Che56]); cf. also [Py73]:

Let $W = (W(\underline{t}))_{\underline{t} \in I^d}$ be a mean-zero Gaussian process with covariance structure

$$(5) \quad \text{cov}(W(\underline{s}), W(\underline{t})) = \underline{s} \wedge \underline{t}, \quad \underline{s}, \underline{t} \in I^d,$$

where $\underline{s} \wedge \underline{t} := \prod_{i \leq d} (s_i \wedge t_i)$ for $\underline{s} = (s_1, \dots, s_d)$ and $\underline{t} = (t_1, \dots, t_d)$; then, if $s_i \leq t_i \quad \forall 1 \leq i \leq d$, we have $\text{cov}(W(\underline{s}), W(\underline{t}) - W(\underline{s})) = \underline{s} \wedge \underline{t} - \underline{s} \wedge \underline{s} = 0$, i.e. under the natural partial ordering of I^d , the property of independent increments has been retained.

The process W is called *Brownian sheet* (cf. [Py73]). A variant of W is the so-called *tied-down Brownian sheet* $U = (U(\underline{t}))_{\underline{t} \in I^d}$, defined by

$$U(\underline{t}) := W(\underline{t}) - W(\underline{1}) \cdot \prod_{i \leq d} t_i, \quad \underline{t} = (t_1, \dots, t_d) \text{ and } \underline{1} = (1, \dots, 1)$$

(i.e. for $d = 1$ U coincides with the Brownian bridge).

Identifying (as in 1.4) each $\underline{t} \in I^d$ with $[0, \underline{t}]^d$, and denoting with ν the Lebesgue measure on I^d , then, with $W([0, \underline{t}]) := W(\underline{t}), \underline{t} \in I^d$, (5) is equivalent to

$$(5') \quad cov(W([0, \underline{s}]), W([0, \underline{t}])) = \nu([0, \underline{s}] \cap [0, \underline{t}]), \quad \underline{s}, \underline{t} \in I^d.$$

But note however that the restriction of Z onto the parameter space I^d is not identical with W , since for $0, \underline{s}$ and \underline{t} being colinear one has

$$(|\underline{t}| + |\underline{s}| - |\underline{t} - \underline{s}|)/2 = |\underline{s}| \neq \underline{s} \wedge \underline{t},$$

in general. Therefore the following question arises:

Is it possible to represent the Lévy-process Z as a set-indexed process $Z' = (Z'(C))_{C \in \mathcal{C}}$ with an appropriately chosen class $\mathcal{C} = \{C_{\underline{t}} : \underline{t} \in \mathbb{R}^d\}$ such that analogously to (5') the covariance of Z' is given by

$$(6) \quad cov(Z'(C_{\underline{s}}), Z'(C_{\underline{t}})) = \mu(C_{\underline{s}} \cap C_{\underline{t}})$$

with a suitable p-measure μ ?

An answer to this question is given in [Os85]:

Let us restrict ourselves to the unit sphere $S^d := \{\underline{t} \in \mathbb{R}^d : |\underline{t}| \leq 1\}$, i.e. consider Lévy's multivariate Brownian motion $Z = (Z(\underline{t}))_{\underline{t} \in S^d}$ as it is done in [Os85], and, for $\underline{t} \in S^d$ let

$$C_{\underline{t}} := \{\underline{v} \in \mathbb{R}^d : |\underline{v} - \underline{t}/2| \leq |\underline{t}/2|\},$$

so that $C_{\underline{t}}$ is the closed sphere in \mathbb{R}^d having for a diameter the ray from 0 to \underline{t} .

$n = 2$:

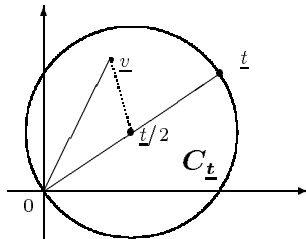

The family $\{C_{\underline{t}} : \underline{t} \in S^d\}$ plays then (as seen below) in the representation of the Lévy Brownian motion Z as a set-indexed process the same role as the class of all lower left orthants $[0, \underline{t}] \cap I^d$ do for the W and U processes with parameter set I^d .

Now, let μ be the p-measure on $S^d \cap \mathcal{B}^d$ with density function f_d (w.r.t. Lebesgue measure) given by

$$f_d(\underline{v}) := (c_d \cdot |\underline{v}|)^{-1}, \quad \underline{v} \in S^d,$$

where $c_d := (2\pi)^{d/2}/(d/2)$ is the surface area of S^d . Then we get

$$(7) \quad \text{For any } \underline{s}, \underline{t} \in S^d \quad \mu(C_{\underline{s}} \cap C_{\underline{t}}) = c_d^{-1} (|\underline{t}| + |\underline{s}| - |\underline{t} - \underline{s}|)/2.$$

Comparing this with (3) we see: For $\underline{s}, \underline{t} \in S^d$ it follows that $\text{cov}(Z(\underline{s}), Z(\underline{t})) = (c_d/2) \cdot \mu(C_{\underline{s}} \cap C_{\underline{t}})$, i.e. with $Z'(C_{\underline{t}}) := (c_d/2)^{-1/2} Z(\underline{t})$ we get

$$\text{cov}(Z'(C_{\underline{s}}), Z'(C_{\underline{t}})) = \mu(C_{\underline{s}} \cap C_{\underline{t}}), \quad \text{i.e. (6).}$$

(Note that scalar multiplication (by $(c_d/2)^{-1/2}$) does not change the process in any essential way.)

Note also that Z' has independent "increments" in the sense that $Z'(C_{\underline{s}})$ and $Z'(C_{\underline{t}})$ are independent if $C_{\underline{s}} \cap C_{\underline{t}} = \emptyset$ $\mu - a.s.$

PROOF OF (7) in the case $d = 2$ (with $c_2 = 2\pi$).

Let $\underline{t} = (t_1, t_2) \in S^2$ and $\underline{a} = (a_1, a_2) \in \partial C_{\underline{t}}$, assuming w.l.o.g. (due to the spherical symmetry of f_d) that $t_1 = 0$ and $a_1 > 0$:

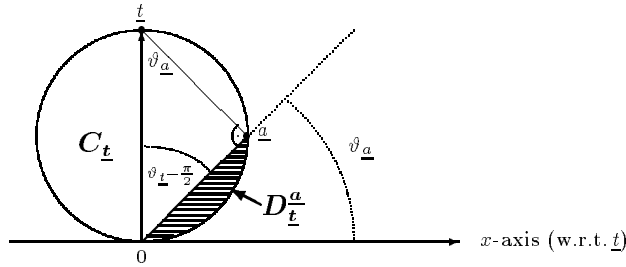

Let $\vartheta_{\underline{a}}$ denote the angle between \underline{a} and the x -axis (w.r.t. \underline{t}) and let $D_{\underline{t}}^{\underline{a}}$ be the hatched region in the figure. Representing $\underline{v} = (v_1, v_2)$ by its polar coordinates, we have

$$\underline{v} = (|\underline{v}| \cos \vartheta, |\underline{v}| \sin \vartheta) \in D_{\underline{t}}^{\underline{a}} \iff 0 \leq |\underline{v}| \leq |\underline{t}| \cos(\vartheta - \frac{\pi}{2}) \text{ and } 0 \leq \vartheta \leq \vartheta_{\underline{a}}.$$

Thus we get (note that $d\underline{v} = |\underline{v}|d|\underline{v}|d\vartheta$):

$$\begin{aligned} \mu(D_{\underline{t}}^{\underline{a}}) &= c_2^{-1} \int_{\mathbb{R}^2} 1_{D_{\underline{t}}^{\underline{a}}}(\underline{v}) \frac{1}{|\underline{v}|} d\underline{v} = c_2^{-1} \int_0^{\vartheta_{\underline{a}}} \int_0^{|\underline{t}| \cos(\vartheta - \frac{\pi}{2})} \frac{1}{|\underline{v}|} |\underline{v}| d|\underline{v}| d\vartheta \\ &= c_2^{-1} \int_0^{\vartheta_{\underline{a}}} |\underline{t}| \cos(\vartheta - \frac{\pi}{2}) d\vartheta = c_2^{-1} |\underline{t}| (\sin(\vartheta_{\underline{a}} - \frac{\pi}{2}) + 1) \\ &= c_2^{-1} (|\underline{t}| - |\underline{t}| \sin(\frac{\pi}{2} - \vartheta_{\underline{a}})) = c_2^{-1} (|\underline{t}| - |\underline{t} - \underline{a}|), \text{ i.e.} \end{aligned}$$

$$(+) \quad \mu(D_{\underline{t}}^{\underline{a}}) = c_2^{-1} (|\underline{t}| - |\underline{t} - \underline{a}|).$$

Considering now $C_{\underline{s}} \cap C_{\underline{t}}$ for $\underline{s} \in S^2$ and $\underline{a} \in \partial C_{\underline{s}} \cap \partial C_{\underline{t}}$, then (where \underline{a}' (see the figure below) takes over the role of \underline{a} before, now with \underline{s} instead of \underline{t})

$$\mu(C_{\underline{s}} \cap C_{\underline{t}}) = \mu(D_{\underline{s}}^{\underline{a}'}) + \mu(D_{\underline{t}}^{\underline{a}}),$$

whence by (+) (noticing that $|\underline{s} - \underline{a}'| = |\underline{s} - \underline{a}|$)

$$\begin{aligned} \mu(C_{\underline{s}} \cap C_{\underline{t}}) &= c_2^{-1} \left(|\underline{s}| - |\underline{s} - \underline{a}'| + |\underline{t}| - |\underline{t} - \underline{a}| \right) = \\ &= c_2^{-1} \left[|\underline{t}| + |\underline{s}| - (|\underline{s} - \underline{a}| + |\underline{t} - \underline{a}|) \right] = c_2^{-1} (|\underline{t}| + |\underline{s}| - |\underline{t} - \underline{s}|), \end{aligned}$$

since $\underline{t} - \underline{a}$ and $\underline{s} - \underline{a}$ are colinear. □

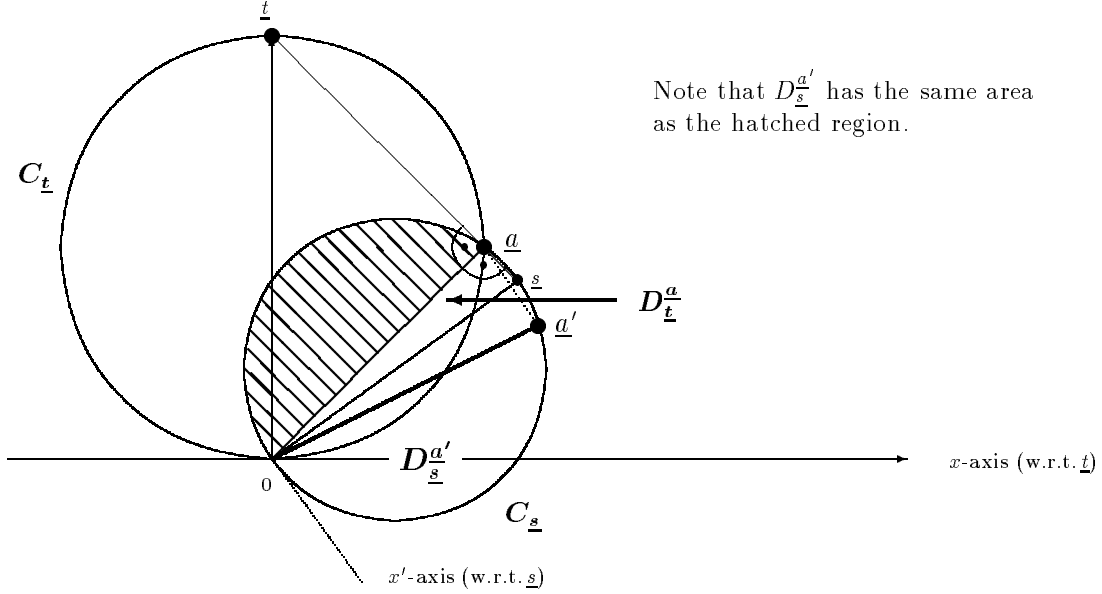

(8) It can be shown that (7) is equivalent to

$$(7') \quad d_\mu(C_{\underline{s}}, C_{\underline{t}}) = 2c_d^{-1} |\underline{t} - \underline{s}| \quad \forall \underline{s}, \underline{t} \in S^d$$

(where $d_\mu(A, B) := \mu(A \Delta B)$). Next (as already remarked in (1.5.4)), the class of all closed Euclidian balls form a VCC, whence

$$\mathcal{C} := \{C_{\underline{t}} : \underline{t} \in S^d\}$$

is also a VCC; thus, we can apply the FCLT 2.2.3 with $X = S^d$, $\mathcal{X} = S^d \cap \mathcal{B}^d$ and $S_n = (S_n(C_{\underline{t}}))_{C_{\underline{t}} \in \mathcal{C}}$, where

$$S_n(C_{\underline{t}}) := n^{-1/2} \sum_{j \leq n} 1_{C_{\underline{t}}}(\eta_j) \cdot \xi_j,$$

the $\xi_j, j \in \mathbb{N}$, being iid with $\mathbb{E}(\xi_j) = 0$ and $\mathbb{E}(\xi_j^2) = 1$, the $\eta_j, j \in \mathbb{N}$, being iid with $\mathcal{L}\{\eta_j\} = \mu$ (having Lebesgue density f_d), and where $(\eta_j)_{j \in \mathbb{N}}$ is independent of $(\xi_j)_{j \in \mathbb{N}}$, to obtain the following result (note

that both conditions (i) and (ii) in Theorem 2.2.3 are obviously fulfilled here):

$$(9) \quad S_n \xrightarrow[\text{sep}]{\mathcal{L}} Z'$$

i.e. Z' proves to be the limiting process of a sequence of Partial-sum processes with random locations.

In addition, $Z' = (Z'(C_{\underline{t}}))_{C_{\underline{t}} \in \mathcal{C}}$ can be chosen as a process with bounded and uniformly d_μ -continuous sample paths; moreover, (7') shows the existence of a version of the Lévy process $Z = (Z(\underline{t}))_{\underline{t} \in S^d}$ with continuous sample paths, cf. above:

$$Z(\underline{t}) = \left(\frac{c_d}{2}\right)^{1/2} Z'(C_{\underline{t}}) \quad \text{for } \underline{t} \in S^d.$$

4 Metric Entropy and Vapnik-Chervonenkis classes

4.1 Packing and covering numbers; Metric Entropy

As we have seen in 1.5, Glivenko-Cantelli convergence, i.e. $\|\nu_n - \nu\|_{\mathcal{C}} \rightarrow 0 \mathbb{P} - a.s.$, fails to hold for all ν if the class \mathcal{C} is “too rich”; cf. our Example 1.5.5.

The same is true in view of the validity of FCLT’s:

Consider again 1.5.5 and the corresponding empirical \mathcal{C} -process $\beta_n = (\beta_n(C))_{C \in \mathcal{C}}$ with $\beta_n(C) := n^{1/2}(\nu_n(C) - \nu(C))$; then: If (as in Theorem 2.2.1) the assertion

$$\beta_n \xrightarrow{\mathcal{L}} \mathbb{G}_\nu \quad \text{in } (l^\infty(\mathcal{C}), \|\cdot\|_{\mathcal{C}})$$

would hold true, the CMT 2.3.16 would imply that

$$\sup_{C \in \mathcal{C}} |\beta_n(C)| \xrightarrow{\mathcal{L}} \sup_{C \in \mathcal{C}} |\mathbb{G}_\nu(C)|,$$

where $\sup_{C \in \mathcal{C}} |\mathbb{G}_\nu(C, \omega)| < \infty$ for all ω , whence $\|\nu_n - \nu\|_{\mathcal{C}} = n^{-1/2} \sup_{C \in \mathcal{C}} |\beta_n(C)| \xrightarrow{\mathbb{P}} 0$ and also $\|\nu_n - \nu\|_{\mathcal{C}} \rightarrow 0 \mathbb{P} - a.s.$ according to 2.1.4, in contradiction to 1.5.5.

Thus, in order to obtain Uniform Laws of Large Numbers (ULLN) and Functional Central Limit Theorems (FCLT) for stochastic processes indexed by general parameter spaces T in section 6 and 7, respectively, it is clear that T is not allowed to be “too rich”.

To be “too rich” will be described through the behaviour of the so-called *metric entropy* of T , assuming that $T = (T, d)$ is a pseudo-metric space.

So, let $T = (T, d)$ be a pseudo-metric parameter space (e.g. $T = \mathcal{C} \subset \mathcal{X}, d = d_\nu, \nu$ p-measure on $\mathcal{X}, d_\nu(C_1, C_2) = \nu(C_1 \Delta C_2)$). Following Dudley ([Du84]) a set $\{t_1, \dots, t_n\} \subset T$ is called a *u-net* (for any given $u > 0$) iff for each $t \in T$ there is some t_i such that $d(t, t_i) \leq u$.

This gives raise to define the so-called *covering numbers* of (T, d) :

4.1.1 Definition.

For each $u > 0$, let

$$N(u, T, d) := \inf\{n \in \mathbb{N} : \exists u\text{-net } \{t_1, \dots, t_n\} \subset T\},$$

i.e. $N(u, T, d)$ is the *minimal number of points in a u-net*. $H(\cdot, T, d) := \log N(\cdot, T, d)$ is called the *metric entropy* of $T = (T, d)$. (Note that $H(u, T, d)$ is increasing as $u \rightarrow 0$.)

(If $d \equiv 0$, that is $d(s, t) = 0 \forall s, t \in T$, we put $N(0, T, d) := 1$, whence in this case $N(u, T, d) \equiv 1$ and therefore $H(u, T, d) = 0 \forall u \geq 0$. So we may allow u to range in $[0, \infty)$.)

A closely related concept are the so-called *packing numbers* of (T, d) . For this, given any $u > 0$, let $D(u, T, d)$ denote the largest m such that for some $t_1, \dots, t_m \in T$ $d(t_i, t_j) > u$ whenever $i \neq j$. The points t_1, \dots, t_m may be called *u-distinguishable*.

4.1.2 Remark.

If $\{t_1, \dots, t_n\}$ is a maximal u -distinguishable set, then $\{t_1, \dots, t_n\}$ is a u -net.

4.1.3 Lemma.

For any $u > 0$

$$D(2u, T, d) \leq N(u, T, d) \leq D(u, T, d).$$

(So, in this sense covering numbers and packing numbers are equivalent concepts.)

As we shall see in section 6 and 7, respectively, in order to obtain a ULLN for RMP's indexed by \mathcal{F} , stochastic boundedness of a sequence of *random* covering numbers of \mathcal{F} (equipped with appropriate *random* pseudo-metrics) will be crucial, whereas, for a FCLT to hold, a uniform integrable L_2 -entropy condition will be imposed.

4.2 Vapnik-Chervonenkis classes in arbitrary sample spaces $X = (X, \mathcal{X})$

Let $X = (X, \mathcal{X})$ be an arbitrary measurable space and $\mathcal{C} \subset \mathcal{X}$ be a VCC (see (1.5.9), i.e.

$$\exists s \in \mathbb{N} \text{ s.t. } m^{\mathcal{C}}(s) < 2^s, \text{ where } m^{\mathcal{C}}(n) := \max\{\Delta^{\mathcal{C}}(F) : F \subset X, |F| = n\}$$

for each $n \in \mathbb{N}$, and $\Delta^{\mathcal{C}}(F) := |\{F \cap C : C \in \mathcal{C}\}|$.

Given a VCC \mathcal{C} , $v \equiv V(\mathcal{C}) := \min\{s \in \mathbb{N} : m^{\mathcal{C}}(s) < 2^s\}$ is the so-called *Vapnik-Chervonenkis Index* of \mathcal{C} .

According to the following lemma VCC's "are of polynomial discrimination".

4.2.1 Lemma ([Vap71]; cf. [Gae83], Lemma 9, p. 27).

If \mathcal{C} is a VCC, then $m^{\mathcal{C}}(n) \leq n^v$ for all $n \geq 2$.

(Note that for arbitrary \mathcal{C} one has $m^{\mathcal{C}}(n) \leq 2^n \forall n \in \mathbb{N}$.)

Moreover, as shown by Alexander ([Al84], inequality (1.8)),

$$\mathcal{C} \text{ VCC} \implies (4.2.2): \quad m^{\mathcal{C}}(n) \leq \sum_{j \leq v-1} \binom{n}{j} \leq \left(\frac{ne}{v-1}\right)^{v-1} \quad \forall n \geq v-1.$$

In the following let (X, \mathcal{X}, ν) be an arbitrary p -space, and, given a class $\mathcal{C} \subset \mathcal{X}$, let $d_{\nu}(C_1, C_2) = \nu(C_1 \Delta C_2)$, $C_1, C_2 \in \mathcal{C}$. Then $(T, d) := (\mathcal{C}, d_{\nu})$ is a pseudo-metric parameter space. In this situation Dudley ([Du78], Lemma 7.13) proved the following fundamental result:

4.2.3 Lemma.

Let $\mathcal{C} \subset \mathcal{X}$ be a VCC; then

$$N(u, \mathcal{C}, d_{\nu}) \leq K u^{-v} |\log u|^v \quad \forall 0 < u \leq 1/2,$$

where the constant $0 < K < \infty$ does only depend on $v \equiv V(\mathcal{C})$ but not on the p -measure ν on \mathcal{X} .

As we shall see in 4.3 below, a corresponding inequality will hold in the more general case of Vapnik-Chervonenkis graph classes \mathcal{F} of \mathcal{X} -measurable functions, containing 4.2.3 as a special case (with $\mathcal{F} = \{1_C : C \in \mathcal{C}\}$).

4.2.4 Examples of VCC's (cf. [Wen81]).

- (a) $X = \mathbb{R}^d, d \geq 1, \mathcal{C} = \{(-\infty, \underline{t}] : \underline{t} \in \mathbb{R}^d\}$ the class of all "lower-left orthants"; $s = d + 1$.
- (b) $X = \mathbb{R}^d, d \geq 1, \mathcal{C} = \{\prod_{i \leq d} [s_i, t_i] : -\infty < s_i \leq t_i < \infty\}$; $s = 2d + 1$.
- (c) $X = \mathbb{R}^d, d \geq 1, \mathcal{C} = \{B \subset \mathbb{R}^d : B \text{ closed Euclidian ball}\}$; $s = d + 2$.

We want to present here an independent nice proof of (c) which I learned from Fleming Topsoe in 1976 (personal communication); the proof is based on the following two auxiliary results (+) and (++):

(+) RADON'S THEOREM (cf. [Val64], Thm. 1.26).

Each $F \subset \mathbb{R}^d, d \geq 1$, with $|F| \geq d+2$, can be decomposed into two (disjoint) subsets $F_i, i = 1, 2$, such that $co(F_1) \cap co(F_2) \neq \emptyset$ (where $co(F_i)$ denotes the convex hull of F_i).

For illustration, let $d = 2$:

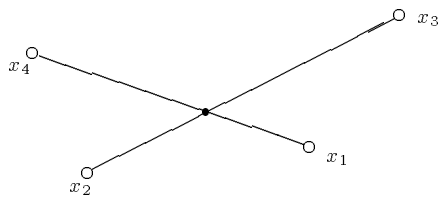

$$F = \{x_1, x_2, x_3, x_4\}$$

$$F_1 = \{x_2, x_3\}$$

$$F_2 = \{x_1, x_4\}.$$

(++) SEPARATION PROPERTY.

For any two closed Euclidian balls $B_i \subset \mathbb{R}^d, d \geq 1, i = 1, 2$, one has

$$co(B_1 \setminus B_2) \cap co(B_2 \setminus B_1) = \emptyset .$$

For illustration, consider again the case $d = 2$:

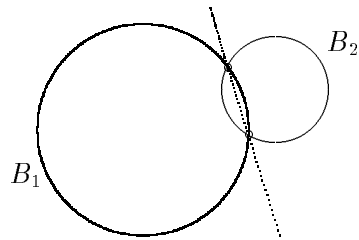

Now, in order to prove (c), we must show:

$$\forall F \subset \mathbb{R}^d \text{ with } |F| = s := d + 2 \exists F' \subset F \text{ s.t. } F' \neq F \cap B \quad \forall B \in \mathcal{C}.$$

Suppose to the contrary that there exists an $F \subset \mathbb{R}^d$ with

$$|F| = d + 2 \quad \text{s.t.} \quad \forall F' \subset F \quad \exists B \in \mathcal{C} \quad \text{with} \quad F' = F \cap B.$$

This implies that for the F_i 's in (+) (which decompose F) there exist two closed Euclidian balls $B_i, i = 1, 2$, such that $F_i = F \cap B_i$. Since $F_1 \cap F_2 = \emptyset$ it follows that $F_1 \subset B_1 \setminus B_2$ and $F_2 \subset B_2 \setminus B_1$, whence

$$\text{co}(B_1 \setminus B_2) \cap \text{co}(B_2 \setminus B_1) \supset \text{co}(F_1) \cap \text{co}(F_2) \neq \emptyset$$

(by (+)) which contradicts (++). □

Further examples of VCC's are obtained on the basis of the following Lemma (cf. [Du78], Thm. 7.2, and [Po84], Chap. II, Lemma 1.8):

4.2.5 Lemma.

Let \mathcal{G} be an arbitrary m -dimensional vectorspace of real-valued functions g being defined on an arbitrary set X equipped with the σ -field $\mathcal{X} = \mathcal{P}(X)$ (whence each $g \in \mathcal{G}$ is measurable). Then the class $\mathcal{C} := \{\{g \geq 0\} : g \in \mathcal{G}\}$ is a VCC.

PROOF. W.l.o.g. let $|X| \geq m + 1$ and let $A = \{x_1, \dots, x_s\} \subset X$ be arbitrary with $|A| = s := m + 1$; consider the linear map $L : \mathcal{G} \rightarrow \mathbb{R}^s$, defined by $L(g) := (g(x_1), \dots, g(x_s))$. Since $L(\mathcal{G})$ is a linear subspace of \mathbb{R}^s with dimension $\leq m = s - 1$, there exists a $v = (v_1, \dots, v_s) \in \mathbb{R}^s, v \neq 0$, s.t. $v \perp L(\mathcal{G})$, i.e. one has

$$(+) \quad \sum_{i \leq s} v_i g(x_i) = 0 \quad \forall g \in \mathcal{G}.$$

Now, let $A_+ := \{x_i \in A : v_i \geq 0\}$ and $A_- := \{x_i \in A : v_i < 0\}$, where w.l.o.g. $A_- \neq \emptyset$ (by replacing v through $-v$ otherwise). We are going to show

$$(++) \quad A_+ \neq A \cap \{g \geq 0\} \quad \forall g \in \mathcal{G},$$

from which the assertion of 4.2.5 follows.

As to (++), suppose to the contrary that there exists a $g \in \mathcal{G}$ s.t. $A_+ = A \cap \{g \geq 0\}$; then

$$\sum_{i \leq s} v_i g(x_i) = \sum_{i: x_i \in A_+} v_i g(x_i) + \sum_{i: x_i \in A_-} v_i g(x_i) > 0$$

in contradiction to (+). □

As an immediate consequence of the definition of a VCC it is clear that any subclass of a VCC is also a VCC.

As a permanence property, we mention here only the following lemma and its corollary:

4.2.6 Lemma ([Du78], Prop. (7.12)).

Let \mathcal{C} be a VCC and $k \in \mathbb{N}$ be arbitrary, but fixed. Given $C_1, \dots, C_k \in \mathcal{C}$, let $\alpha(C_1, \dots, C_k)$ be the algebra generated by C_1, \dots, C_k and

$$\alpha_k(\mathcal{C}) := \bigcup \{\alpha(C_1, \dots, C_k) : C_1, \dots, C_k \in \mathcal{C}\};$$

then $\alpha_k(\mathcal{C})$ is also a VCC.

4.2.7 Corollary.

If \mathcal{C} is a VCC, then the classes $\{C\Delta D : C, D \in \mathcal{C}\}$, $\{C \setminus D : C, D \in \mathcal{C}\}$ and $\{C \cap D : C, D \in \mathcal{C}\}$, respectively, form also VCC's.

As to further examples we refer to Stengle and Yukich [Sten89] and Laskowski [La92]; see also the references in the following more general context.

4.3 Vapnik-Chervonenkis graph classes of \mathcal{X} -measurable functions $f : X \rightarrow \mathbb{R}$

So far we have mainly considered examples of processes indexed by classes \mathcal{C} of sets, where $\mathcal{C} \subset \mathcal{X}$, (X, \mathcal{X}) being a given measurable space.

To motivate the need for extending the index sets from classes of sets to classes of functions, we present the following examples A) and B):

A) POLLARD'S k -MEANS CLUSTERING PROCEDURE

(Cf. [Po84], Example 4, p.9 and Example 29, p. 30; [Po82a] and [Po82b]; [Gae87]; [Ro91] and [Ro95].)

Given data $x_1, \dots, x_n \in X = \mathbb{R}^d$ viewed as realizations of iid re's ξ_j in $(\mathbb{R}^d, \mathcal{B}^d)$ (on a basic p-space $(\Omega, \mathcal{A}, \mathbb{P})$) (i.e. $x_j = \xi_j(\omega)$), let $k \in \mathbb{N}$ be arbitrary but fixed (i.e. k is given in advance).

Suppose that the underlying unknown $\nu := \mathcal{L}\{\xi_j\}$ is " k -modal" (e.g. with Lebesgue-density φ_ν having k modes).

Consider $d = 2$ and $k = 2$ for illustration (i.e. φ_ν bimodal)

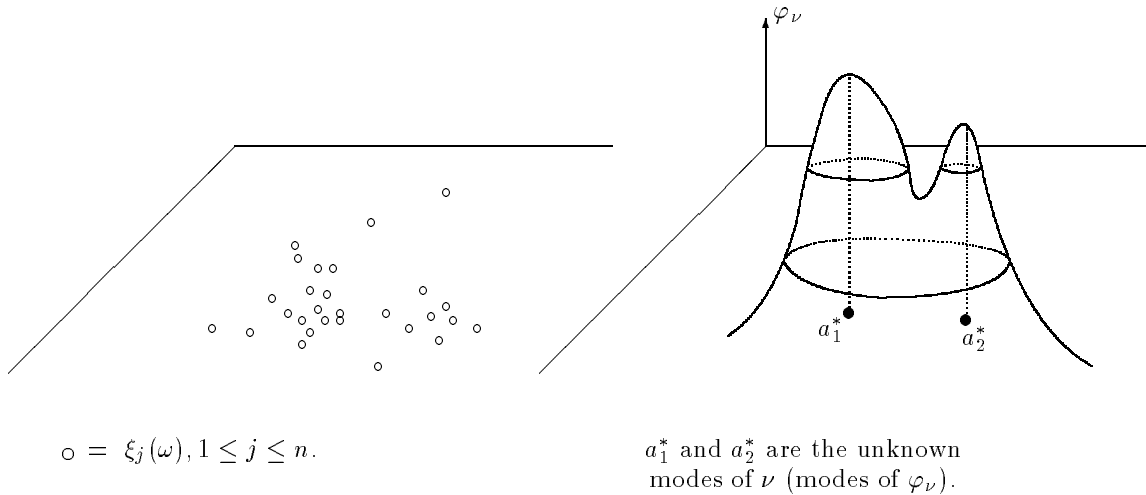

The question arises how to choose k data-clusters with empirical cluster centers $a_{ni}^* = a_{ni}^*(\omega)$ (based on the data $x_j = \xi_j(\omega), 1 \leq j \leq n$), $1 \leq i \leq k$, such that, as the sample size n tends to infinity, the

a_{ni}^* converge $\mathbb{P} - a.s.$ to the unknown modes a_i^* of ν , $1 \leq i \leq k$.

An answer is provided by the *k-means clustering procedure (CP)*:

(CP): Given the data $x_j (= \xi_j(\omega))$, $1 \leq j \leq n$, $n \in \mathbb{N}$, determine a k -tuple $(a_{n1}^*, \dots, a_{nk}^*)$ which minimizes the expression

$$(4.3.1) \quad n^{-1} \sum_{j \leq n} \min_{1 \leq i \leq k} |x_j - a_i|^2$$

over all (a_1, \dots, a_k) with $a_i \in \mathbb{R}^d$, and then allocate each x_j to its nearest a_{ni}^* .

Let ν_n be the empirical measure based on ξ_1, \dots, ξ_n and let for $a_i \in \mathbb{R}^d$, $1 \leq i \leq k$,

$$(4.3.2) \quad W(a_1, \dots, a_k; \nu_n) := \int_{\mathbb{R}^d} \min_{1 \leq i \leq k} |x - a_i|^2 \nu_n(dx);$$

then

$$(4.3.3) \quad W(a_{n1}^*, \dots, a_{nk}^*; \nu_n) = \min_{(a_1, \dots, a_k)} W(a_1, \dots, a_k; \nu_n).$$

In the following we confine to the case $d = 1$ and $k = 2$) (i.e. ν being bimodal), and we shall write (a_n^*, b_n^*) and (a^*, b^*) instead of (a_{n1}^*, a_{n2}^*) and (a_1^*, a_2^*) , respectively.

Now, consider (instead of a class \mathcal{C} of sets) the following class \mathcal{F} of \mathcal{B} -measurable functions $f : \mathbb{R} \rightarrow \mathbb{R}$:

$$(4.3.4) \quad \mathcal{F} := \{f_{a,b} : (a, b) \in C_M\}$$

where $f_{a,b}(x) := |x - a|^2 \wedge |x - b|^2$, $x \in \mathbb{R}$, and $C_M := ([-M, M] \times \mathbb{R}) \cup (\mathbb{R} \times [-M, M])$, where $M > 0$ is chosen large enough (see [Po84], p.10).

We assume that

$$\int_{\mathbb{R}} x^2 \nu(dx) < \infty,$$

whence $W(a, b; \nu) := \int_{\mathbb{R}} f_{a,b}(x) \nu(dx) < \infty \quad \forall (a, b) \in \mathbb{R}^2$.

Then, by the strong law of large numbers we have $\forall (a, b) \in \mathbb{R}^2$

$$(4.3.5) \quad W(a, b; \nu_n) = \nu_n(f_{a,b}) = n^{-1} \sum_{j \leq n} f_{a,b}(\xi_j) \longrightarrow \nu(f_{a,b}) = W(a, b; \nu) \quad \mathbb{P} - a.s.$$

Now, a further assumption on ν is needed:

(4.3.6) $\exists (a^*, b^*) \in \mathbb{R}^2$ being uniquely determined up to permutation of its coordinates such that

$$\nu(f_{a^*, b^*}) = \min_{(a, b) \in \mathbb{R}^2} \nu(f_{a,b}).$$

The following picture is to visualize (4.3.6) for ν with density φ_ν :

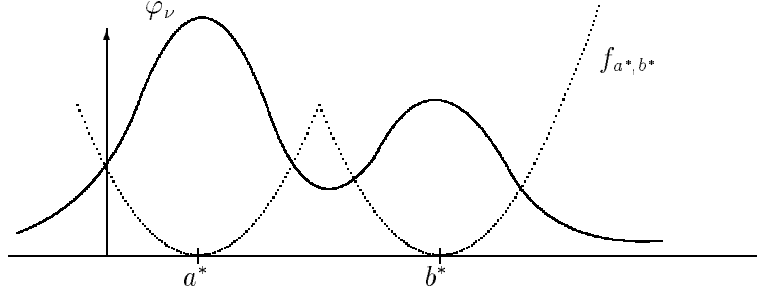

On the other hand, i.e. on the empirical side, we have by (4.3.3)

$$(4.3.7) \quad \nu_n(f_{a_n^*, b_n^*}) = \min_{(a,b) \in \mathbb{R}^2} \nu_n(f_{a,b}).$$

Thus, (4.3.5) - (4.3.7) gives raise to expect

$$(4.3.8) \quad (a_n^*, b_n^*) \longrightarrow (a^*, b^*) \quad \mathbb{P} - a.s.$$

i.e. $\mathbb{P} - a.s$ convergence of the empirical cluster centers to the unknown modes of ν .

(4.3.8) can be proved by showing

$$(4.3.9) \quad \sup_{(a,b) \in C_M} |\nu_n(f_{a,b}) - \nu(f_{a,b})| \longrightarrow 0 \quad \mathbb{P} - a.s.$$

As to (4.3.9), $\sup_{(a,b) \in C_M} |\nu_n(f_{a,b}) - \nu(f_{a,b})| = \sup_{f \in \mathcal{F}} |\nu_n(f) - \nu(f)|$ with \mathcal{F} as defined by (4.3.4) being a Vapnik-Chervonenkis graph class (VCGC) (see below for the definition of VCGC's of functions). Thus (4.3.9) proves to be a consequence of a result generalizing Theorem 2.1.6 from VCC's \mathcal{C} to VCGC's \mathcal{F} with $\nu(F) < \infty$, F being an envelope of \mathcal{F} ; note that in the present case

$$\sup_{(a,b) \in C_M} f_{a,b}(x) \leq F(x) := (x - M)^2 + (x + M)^2 \quad \forall x \in \mathbb{R}$$

and $\nu(F) < \infty$ since $\int_{\mathbb{R}} x^2 \nu(dx) < \infty$ by assumption. (Cf. [Po84], Example 29, and section 6.3 below).

To sketch the proof of (4.3.8) on the basis of (4.3.9) one shows at first

(a): For sufficiently large $M > 0$ $(a_n^*, b_n^*) \in C_M$ $\mathbb{P} - a.s.$ $\forall n \geq n_0$.

Then one gets

(b): $\nu_n(f_{a_n^*, b_n^*}) \stackrel{(4.3.7)}{\leq} \nu_n(f_{a^*, b^*}) \longrightarrow \nu(f_{a^*, b^*})$ $\mathbb{P} - a.s.$ by (4.3.5), where $\mathbb{P} - a.s.$

$\nu(f_{a^*, b^*}) \stackrel{(4.3.6)}{\leq} \nu(f_{a_n^*, b_n^*}) \underset{\substack{\text{for large } n \\ \text{by (4.3.9) and (a)}}}{\approx} \nu_n(f_{a_n^*, b_n^*})$, which yields

$$\nu(f_{a_n^*, b_n^*}) \longrightarrow \nu(f_{a^*, b^*}) \quad \mathbb{P} - a.s.$$

(c): Finally, since by (4.3.6) (a^*, b^*) is uniquely determined (up to permutation of its coordinates), (b) implies (4.3.8). \square

A modification of the k -means clustering procedure for k^* -modal ν with k^* *unknown* to obtain \mathbb{P} -a.s. convergence of $k(n)$ to k^* and simultaneously

$$(4.3.8') \quad (a_{n1}^*, \dots, a_{nk(n)}^*) \longrightarrow (a_1^*, \dots, a_{k^*}^*) \quad \mathbb{P} - a.s.,$$

where $k(n)$ denotes the number of empirical clusters w.r.t. a modification of the empirical clustering procedure, is contained in [Gae87], [Ro91] and [Ro95].

B) LOCAL EMPIRICAL PROCESSES, STUTE'S CONDITIONAL EMPIRICAL PROCESSES AND CONDITIONAL EMPIRICAL DISTRIBUTION FUNCTIONS

(See [Ei97], [Stu86a] and [Stu86b].)

As pointed out in [Ei97], local empirical processes occur implicitly in the work of Kim and Pollard [Ki90] on cube root asymptotics and of Nolan and Marron [No89] on automatic band width selection; local empirical-type processes arise also in certain interval censoring and deconvolution problems (see Part II of Groeneboom and Wellner [Gro92]).

Let $\xi_j, j \in \mathbb{N}$, be iid re's in $(\mathbb{R}^d, \mathcal{B}^d), d \geq 1$, defined on a p-space $(\Omega, \mathcal{A}, \mathbb{P})$ with df G .

Let $\underline{t} \in \mathbb{R}^d$ and $J \in \mathcal{B}^d$ be arbitrary, but fixed. Given an invertible bimeasurable transformation $h : \mathbb{R}^d \longrightarrow \mathbb{R}^d$, let

$$(4.3.10) \quad A(h) := \underline{t} + hJ \quad (\text{where } hJ := \{h(\underline{x}) : \underline{x} \in J\}).$$

To visualize $A(h)$, let $d = 2, J = E$ (the unit ball in \mathbb{R}^2) and $h(\underline{x}) := \frac{1}{2}|\underline{x}|, \underline{x} \in \mathbb{R}^2$:

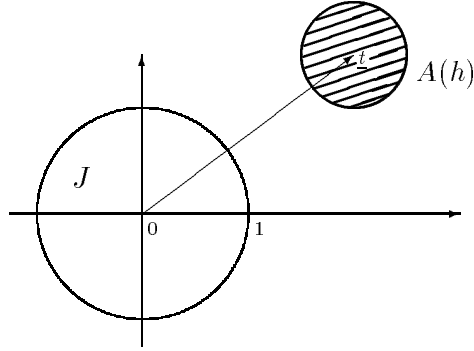

Next, let $(h_n)_{n \in \mathbb{N}}$ be a sequence of invertible bimeasurable transformations $h : \mathbb{R}^d \longrightarrow \mathbb{R}^d$ and assume for

$$A_n := A(h_n) \quad \text{and} \quad a_n := \mathbb{P}(\xi_j \in A_n), \quad n \in \mathbb{N},$$

the following set of conditions

$$(A.i) \quad a_n > 0 \quad \forall n \in \mathbb{N}, \quad (A.ii) \quad na_n \longrightarrow \infty \quad \text{and} \quad (A.iii) \quad a_n \longrightarrow 0 \quad \text{as } n \longrightarrow \infty.$$

(Note that (A.iii) implies that G is continuous at \underline{t} ; otherwise (A.iii) may be replaced by (A.iii') $a_n \rightarrow a$ for some $0 \leq a \leq 1$.)

For each $n \in \mathbb{N}$, let $\nu_n(\underline{t}, \cdot)$ be defined by

$$(4.3.11) \quad \nu_n(\underline{t}, B) := (na_n)^{-1} \sum_{j \leq n} I(\xi_j \in \underline{t} + h_n(J \cap B)), B \in \mathcal{B}^d$$

(where $I(\cdot) \equiv 1_{\{\cdot\}}$).

$\nu_n(\underline{t}, \cdot)$ is called *local empirical measure* at \underline{t} .

(Note that $\nu_n(\underline{t}, \cdot)$ need not be a probability measure; one only has that $\mathbb{E}(\nu_n(\underline{t}, \mathbb{R}^d)) = 1$.)

Now, let \mathcal{F} be a class of measurable functions $f : \mathbb{R}^d \rightarrow \mathbb{R}$ with supports contained in J (i.e. $f(x) = 0 \forall x \in \mathbb{R}^d \setminus J \forall f \in \mathcal{F}$), and let

$$(4.3.12) \quad \nu_n(\underline{t}, f) := \int_J f(x) \nu_n(\underline{t}, dx) \stackrel{(4.3.11)}{=} (na_n)^{-1} \sum_{j \leq n} f(h_n^{-1}(\xi_j - \underline{t})), f \in \mathcal{F},$$

where h_n^{-1} denotes the inverse of h_n .

◦ Note at this place that for any fixed $\underline{t} \in \mathbb{R}^d$ and $J \in \mathcal{B}^d$ the processes $(\nu_n(\underline{t}, f))_{f \in \mathcal{F}}$ can be considered as RMP's (see (3.1.1)) by choosing as random p-measures w_{nj} and as rv's ξ_{nj} , $1 \leq j \leq n$, $n \in \mathbb{N}$,

$$w_{nj} := \delta_{\eta_{nj}} \text{ with } \eta_{nj} := h_n^{-1}(\xi_j - \underline{t}), \text{ and } \xi_{nj} := (na_n)^{-1}.$$

(In fact, for each $f \in \mathcal{F}$, $\sum_{j \leq n} w_{nj}(f) \xi_{nj} = (na_n)^{-1} \sum_{j \leq n} \int_{\mathbb{R}^d} f(x) \delta_{\eta_{nj}}(dx) = (na_n)^{-1} \sum_{j \leq n} f(\eta_{nj}) = (na_n)^{-1} \sum_{j \leq n} f(h_n^{-1}(\xi_j - \underline{t})) = \nu_n(\underline{t}, f)$.)

The standardized process $\beta_n^{loc}(\underline{t}) = (\beta_n^{loc}(\underline{t}, f))_{f \in \mathcal{F}}$ with $\beta_n^{loc}(\underline{t}, f) := (na_n)^{1/2} (\nu_n(\underline{t}, f) - \mathbb{E}(\nu_n(\underline{t}, f)))$ is called *local empirical process* at \underline{t} indexed by \mathcal{F} .

This setup allows to consider the following interesting examples (see [Ei97]):

4.3.13 Example.

Let $\xi_j, j \in \mathbb{N}$, be iid rv's on a p-space $(\Omega, \mathcal{A}, \mathbb{P})$ with df G having a continuous density g in a neighborhood of a fixed $t \in \mathbb{R}$.

Set $J := [-\frac{1}{2}, \frac{1}{2}]$, $\mathcal{F} := \{K\}$ with a so-called kernel function K satisfying $K(x) = 0$ if $|x| > \frac{1}{2}$.

Let $h_n(x) := h_n \cdot x$, $x \in \mathbb{R}$, with $h_n > 0$ and $h_n \rightarrow 0$ as $n \rightarrow \infty$. Then,

$$\nu_n(t, K) \stackrel{(4.3.12)}{=} (na_n)^{-1} \sum_{j \leq n} K\left(\frac{\xi_j - t}{h_n}\right) = h_n a_n^{-1} \hat{g}_n(t),$$

where $\hat{g}_n(t) := (nh_n)^{-1} \sum_{j \leq n} K\left(\frac{\xi_j - t}{h_n}\right)$ is the so-called kernel density estimator of $g(t)$ with window size h_n .

(Note that $h_n^{-1} a_n = h_n^{-1} \mathbb{P}(\xi_j \in t + h_n J) = h_n^{-1} \mathbb{P}(\xi_j \in [t - \frac{1}{2}h_n, t + \frac{1}{2}h_n]) = h_n^{-1} \int_{t - \frac{1}{2}h_n}^{t + \frac{1}{2}h_n} g(x) dx \rightarrow g(t)$ as $n \rightarrow \infty$.)

4.3.14 Example.

Let $d = 2$, $\xi_j = (\zeta_j, \eta_j)$, $j \in \mathbb{N}$, iid re's in $(\mathbb{R}^2, \mathcal{B}^2)$ with df G having density $g_{\zeta, \eta}$ and marginal densities g_ζ and g_η , respectively. Choose $J := [-\frac{1}{2}, \frac{1}{2}] \times \mathbb{R}$, $\underline{t} := (t, 0)$, $t \in \mathbb{R}$, and, for $(z, y) \in \mathbb{R}^2$ let $h_n(z, y) := (h_n \cdot z, y)$ with $h_n > 0$ and $h_n \rightarrow 0$ as $n \rightarrow \infty$. Let K be a kernel function as in 4.3.13 and $\mathcal{F} := \{R\}$ with

$$(+) \quad R(z, y) := y \cdot K(z) \quad , (z, y) \in \mathbb{R}^2.$$

Then,

$$\nu_n(\underline{t}, R) \stackrel{(4.3.12)}{=} (na_n)^{-1} \sum_{j \leq n} R(h_n^{-1}(\xi_j - \underline{t})) = (na_n)^{-1} \sum_{j \leq n} \eta_j K\left(\frac{\zeta_j - t}{h_n}\right),$$

since $h_n^{-1}(\xi_j - \underline{t}) = h_n^{-1}(\zeta_j - t, \eta_j) = (\frac{\zeta_j - t}{h_n}, \eta_j)$ and therefore $R(h_n^{-1}(\xi_j - \underline{t})) = R\left(\frac{\zeta_j - t}{h_n}, \eta_j\right) \stackrel{(+)}{=} \eta_j K\left(\frac{\zeta_j - t}{h_n}\right)$.

Thus

$$\nu_n(\underline{t}, R) = \hat{m}_n(t) h_n a_n^{-1} \hat{g}_n(t) = \hat{m}_n(t) \nu_n(t, K) \quad (\text{cf. 4.3.13}),$$

where $\hat{g}_n(t)$ is the kernel density estimator of the marginal density $g_\zeta(t)$ and $\hat{m}_n(t)$ is the kernel regression estimator of $m(t) := \mathbb{E}(\eta | \zeta = t)$ defined by

$$\hat{m}_n(t) := \frac{(nh_n)^{-1} \sum_{j \leq n} \eta_j K\left(\frac{\zeta_j - t}{h_n}\right)}{\hat{g}_n(t)}.$$

4.3.15 Example.

Keeping up the notation of example 4.3.14, choose now, instead of $\mathcal{F} = \{R\}$, the class $\mathcal{F} = \{f_v : v \in \mathbb{R}\}$ of functions f_v defined by

$$f_v(z, y) := I(y \leq v) K(z), \quad (z, y) \in \mathbb{R}^2;$$

then (again with $\underline{t} = (t, 0)$, $t \in \mathbb{R}$)

$$\begin{aligned} \nu_n(\underline{t}, f_v) &:= (na_n)^{-1} \sum_{j \leq n} I(\eta_j \leq v) K\left(\frac{\zeta_j - t}{h_n}\right) = F_n(v|t) h_n a_n^{-1} \hat{g}_n(t) \\ &= F_n(v|t) \nu_n(t, K) \quad (\text{cf. 4.3.13}) \end{aligned}$$

with

$$F_n(v|t) := \frac{(nh_n)^{-1} \sum_{j \leq n} I(\eta_j \leq v) K\left(\frac{\zeta_j - t}{h_n}\right)}{\hat{g}_n(t)},$$

which are the conditional empirical distribution functions (of sample size n) first intensively studied by Stute [Stu86a],[Stu86b].

As to an empirical process approach to the uniform consistency of kernel-type function estimators we refer to a very remarkable forthcoming paper by Uwe Einmahl and David Mason [Ei98].

In the following let again $X = (X, \mathcal{X})$ be an arbitrary measurable space and \mathcal{F} be a class of \mathcal{X} -measurable functions $f : X \rightarrow \mathbb{R}$ with \mathcal{X} -measurable envelope $F : X \rightarrow \mathbb{R}_+$ (i.e. $\sup_{f \in \mathcal{F}} |f(x)| \leq F(x) \forall x \in X$).

Generalizing the concept of VCC's $\mathcal{C} \subset \mathcal{X}$ (equivalently $\{1_C : C \in \mathcal{C}\}$) to more general classes \mathcal{F} of \mathcal{X} -measurable functions $f : X \rightarrow \mathbb{R}$ leads to

4.3.16 Definition.

\mathcal{F} is called a *Vapnik-Chervonenkis graph class (VCGC)* if

$$\mathcal{R} := \{G_f : f \in \mathcal{F}\}$$

is a VCC in $(X \times \mathbb{R}, \mathcal{X} \otimes \mathcal{B})$, where

$$G_f := \{(x, t) \in X \times \mathbb{R} : 0 \leq t \leq f(x) \text{ or } f(x) \leq t \leq 0\}.$$

$G_f \subset X \times \mathbb{R}$ is the so-called *graph region* associated to f .

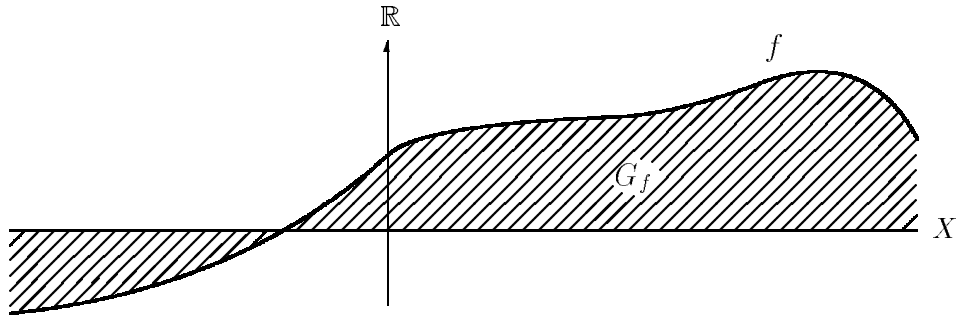

NOTE: f \mathcal{X} -measurable $\implies G_f \in \mathcal{X} \otimes \mathcal{B}$ whence the *graph region class* \mathcal{R} is a subclass of $\mathcal{X} \otimes \mathcal{B}$.

Given a VCGC \mathcal{F} we denote with $V(\mathcal{R})$ the Vapnik-Chervonenkis Index of the graph region class \mathcal{R} (cf. 4.2) corresponding to \mathcal{F} .

Clearly, if $\mathcal{C} \subset \mathcal{X}$ is a VCC, then $\mathcal{F} := \{1_C : C \in \mathcal{C}\}$ is a VCGC with $V(\mathcal{R}) = V(\mathcal{C})$.

Examples of VCGC's as well as permanence properties which allow to construct new VCGC's from known ones are contained in [Po84] (there called "classes of polynomial discrimination") and [Va96], section 2.6.5.

The present graph regions G_f are called "*between graphs*" in [Va96]; compared with the open *subgraphs* of f , defined by $\{(x, t) : t < f(x)\}$, which led to the concept of *Vapnik-Chervonenkis subgraph classes (VCSGC)* of functions in [Va96], section 2.6.2, it turns out that \mathcal{F} is a VCGC if and only if it is a VCSGC; see [Va96], Problem 11, p. 152. Thus both concepts are equivalent.

The following fundamental lemma is mentioned in [Al84]. It generalizes lemma 4.2.3 above; but notice that in addition the assumption of ν being a p-measure on \mathcal{X} can be dispensed with. The proof, as carried out by Klaus Ziegler [Zi94], Lemma A4, combines the methods in proving lemma 2.7 in [Al84] and lemma 25 in section II.5 of [Po84].

4.3.17 Lemma.

Let \mathcal{F} be a VCGC with envelope F and graph region class \mathcal{R} . Then there exists a constant $0 < K(v) < \infty$ depending only on $v \equiv V(\mathcal{R})$ such that for all measures ν on \mathcal{X} with $\nu(F) := \int_{\mathcal{X}} F d\nu < \infty$

$$N(\varepsilon\nu(F), \mathcal{F}, d_\nu^{(1)}) \leq K(v)\varepsilon^{-(v-1)}|\log \varepsilon|^{v-1} \quad \forall 0 < \varepsilon \leq \frac{1}{2}.$$

Here, as in 4.2.3, $\log \varepsilon = \log_e \varepsilon \equiv \ln \varepsilon$, and $d_\nu^{(1)}$ is defined by $d_\nu^{(1)}(f, g) := \nu(|f - g|)$, $f, g \in \mathcal{F}$.

NOTE: $\lim_{\varepsilon \rightarrow 0} |\log \varepsilon|^\alpha \varepsilon^\beta = 0 \quad \forall \alpha, \beta > 0$, so $|\log \varepsilon|^{v-1} \leq \varepsilon^{-(v-1)}$ for small ε , whence

$$N(\varepsilon\nu(F), \mathcal{F}, d_\nu^{(1)}) \leq K(v)\varepsilon^{-2(v-1)} \quad \forall 0 < \varepsilon \leq \frac{1}{2}.$$

Also, in the special case $\mathcal{F} := \{1_C : C \in \mathcal{C}\}$, \mathcal{C} VCC, $F \equiv 1$, $d_\nu^{(1)} = d_\nu$, ν an arbitrary p-measure on \mathcal{X} , 4.3.17 yields a sharpened version of 4.2.3.

PROOF. W.l.o.g. assume $v \geq 2$; let $0 < \varepsilon \leq \frac{1}{2}$ be arbitrary, but fixed, and choose $f_1, \dots, f_m \in \mathcal{F}$ (w.l.o.g. $m \geq 2$) s.t.

$$(1) \quad d_\nu^{(1)}(f_i, f_j) := \nu(|f_i - f_j|) > \varepsilon\nu(F) \quad \text{for } i \neq j.$$

Let n be the smallest natural number s.t.

$$(2) \quad \frac{1}{2} \exp(2 \log m - n\varepsilon/2) < 1.$$

Then, by elementary calculations, one gets

$$(3) \quad n \leq (1 + 4 \log m)/\varepsilon \leq 15Lm/\varepsilon$$

where $La := \max(1, \log a)$.

Now, a stochastic argument comes into play (cf. Dudley's ingenious proof of lemma 4.2.3):

Let μ be the p-measure on \mathcal{X} defined by

$$\mu(A) := \nu(F)^{-1} \int_A F d\nu, \quad A \in \mathcal{X},$$

and let $K : \mathcal{X} \times \mathcal{B} \rightarrow [0, 1]$ be the stochastic kernel defined by

$$K(x, B) := U[-F(x), F(x)], \quad x \in \mathcal{X}, B \in \mathcal{B},$$

where $U[a, b]$ denotes the uniform distribution on $[a, b]$. Let ξ_1, \dots, ξ_n (with n chosen as above, cf. (2)) be iid r's in $(\mathcal{X} \times \mathbb{R}, \mathcal{X} \otimes \mathcal{B})$, defined on a basic p-space $(\Omega, \mathcal{A}, \mathbb{P})$, with $\mathcal{L}\{\xi_j\} = \mu \times K$, where $\mu \times K$ is the p-measure on $\mathcal{X} \otimes \mathcal{B}$ defined by

$$\mu \times K(C) := \int_{\mathcal{X}} U[-F(x), F(x)](\{t \in \mathbb{R} : (x, t) \in C\}) \mu(dx), \quad C \in \mathcal{X} \otimes \mathcal{B}.$$

(To see that K is indeed a stochastic kernel, use the fact that \mathcal{X} -measurability of $K(\cdot, B)$ has only to be checked for sets B of the form $(-\infty, t], t \in \mathbb{R}$. So, fix $t \in \mathbb{R}$ and distinguish between the three cases $t > 0$, $t = 0$, and $t < 0$. Then, e.g. in the case $t > 0$ we obtain

$$K(\cdot, (-\infty, t]) = 1_{\{F \leq t\}} + ((t + F)/2F) 1_{\{F > t\}}$$

which is \mathcal{X} -measurable by the assumed measurability of F .)

Now, let $G_i := G_{f_i}$ be the graph regions of $f_i, 1 \leq i \leq m$; then (with the convention that in the case $F(x) = 0$ we set $\frac{0}{0} := 0$)

$$(4) \quad U[-F(x), F(x)](\{t \in \mathbb{R} : (x, t) \in G_i \Delta G_j\}) = (2F(x))^{-1}|f_i(x) - f_j(x)| \quad \forall x \in X,$$

as the following picture shows (with $G_i \Delta G_j$ being the hatched region).

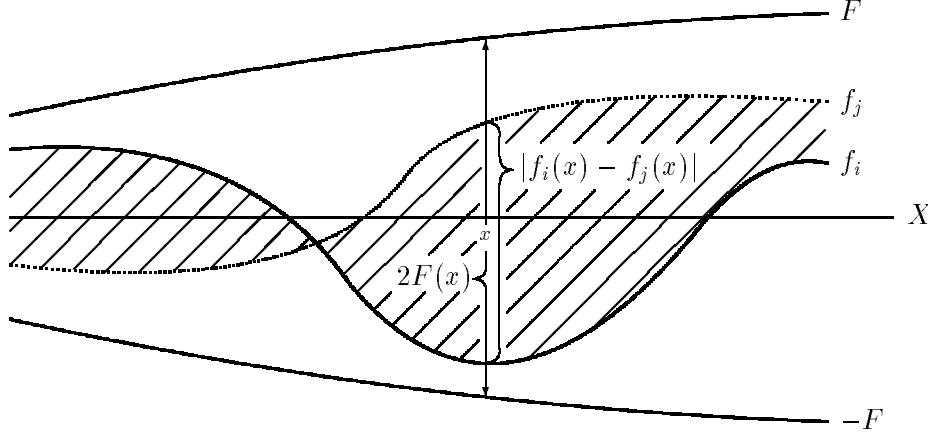

Furthermore, we have

$$(5) \quad \forall \xi_k(\omega), \omega \in \Omega, 1 \leq k \leq n, \text{ and } \forall 1 \leq i, j \leq m, i \neq j \\ S'(\omega) \cap G_i = S'(\omega) \cap G_j \iff \xi_k(\omega) \notin G_i \Delta G_j \quad \forall 1 \leq k \leq n, \\ \text{where } S'(\omega) := \{\xi_1(\omega), \dots, \xi_n(\omega)\}.$$

(Note that $S'(\omega) \cap G_i \neq S'(\omega) \cap G_j \iff \exists 1 \leq k_0 \leq n$ s.t. $\xi_{k_0}(\omega) \in G_i \Delta G_j$; note also that $|S'(\omega)| \leq n$.)

Next, we are going to show that

$$m \leq m^{\mathcal{R}}(n) := \max \left\{ |\{S \cap G_f : f \in \mathcal{F}\}| : S \subset X \times \mathbb{R}, |S| = n \right\} :$$

For this, consider first any fixed $1 \leq i, j \leq m, i \neq j$; then

$$\begin{aligned} \mathbb{P}(\xi_k \notin G_i \Delta G_j \quad \forall 1 \leq k \leq n) & \stackrel{(\xi_k \text{ i.i.d.})}{=} [1 - \mathbb{P}(\xi_1 \in G_i \Delta G_j)]^n = [1 - (\mu \times K)(G_i \Delta G_j)]^n \\ & = [1 - \int_X U[-F(x), F(x)](\{t \in \mathbb{R} : (x, t) \in G_i \Delta G_j\}) \mu(dx)]^n \\ & \stackrel{(4)}{=} [1 - \int_X (2F(x))^{-1}|f_i(x) - f_j(x)| \mu(dx)]^n \\ & = [1 - \nu(|f_i - f_j|)(2\nu(F))^{-1}]^n \stackrel{(1)}{\leq} (1 - \varepsilon/2)^n \leq \exp(-n\varepsilon/2). \end{aligned}$$

Therefore, according to (5) we get

$$\begin{aligned} \mathbb{P}(\{\omega \in \Omega : \exists i \neq j \text{ s.t. } S'(\omega) \cap G_i = S'(\omega) \cap G_j\}) &< \binom{m}{2} \exp(-n\varepsilon/2) \\ &\leq \frac{1}{2} m^2 \exp(-n\varepsilon/2) = \frac{1}{2} \exp(2 \log m - n\varepsilon/2) \stackrel{(2)}{<} 1, \end{aligned}$$

whence

$$\mathbb{P}(\{\omega \in \Omega : S'(\omega) \cap G_i \neq S'(\omega) \cap G_j \quad \forall 1 \leq i, j \leq m, i \neq j\}) > 0.$$

Therefore there exist $\leq n$ points in $X \times \mathbb{R}$ from which \mathcal{R} picks out m distinct subsets of $S'(\omega_0)$ for some $\omega_0 \in \Omega$. Since $S'(\omega_0) \subset X \times \mathbb{R}$ and $|S'(\omega_0)| \leq n$, it follows (by definition of $m^{\mathcal{R}}(n)$ and the fact that $m^{\mathcal{R}}(n)$ is increasing in n) that $m \leq m^{\mathcal{R}}(n)$, whence by (3)

$$m \leq m^{\mathcal{R}}(15Lm/e\varepsilon).$$

Now, if $\underline{15Lm/e\varepsilon \geq v-1}$, it follows by (4.2.2) (according to which $m^{\mathcal{R}}(n) \leq \left(\frac{ne}{v-1}\right)^{v-1} \forall n \geq v-1$) that $m \leq m^{\mathcal{R}}(15Lm/e\varepsilon) \leq (15Lm/(v-1)\varepsilon)^{v-1}$, which implies

$$(6) \quad m \leq (30\varepsilon^{-1} \log(15\varepsilon^{-1}))^{v-1}.$$

(In fact, since $Lm/(v-1) \leq L(m^{1/(v-1)}) \leq m^{1/2(v-1)}$, we have $m \leq 15^{v-1} m^{1/2} \varepsilon^{-(v-1)}$ and thus $m \leq (15\varepsilon^{-1})^{2(v-1)}$. Hence $m \leq (15L((15\varepsilon^{-1})^{2(v-1)})/(v-1)\varepsilon)^{v-1} = (30\varepsilon^{-1} \log(15\varepsilon^{-1}))^{v-1}$.)

On the other hand, if $\underline{15Lm/e\varepsilon < v-1}$, it follows that $\log m \leq Lm < e\varepsilon(v-1)/15 < \varepsilon(v-1) \leq (v-1) \log(30\varepsilon^{-1}) = \log[(30\varepsilon^{-1})^{v-1}]$, whence $m \leq (30\varepsilon^{-1})^{v-1} \stackrel{(\varepsilon \leq 1/2)}{\leq} (30\varepsilon^{-1} \log(15\varepsilon^{-1}))^{v-1}$; i.e. (6)

holds also true in this case.

But (6) implies (recall $\varepsilon \leq 1/2$)

$$(7) \quad m \leq K(v) \varepsilon^{-(v-1)} |\log \varepsilon|^{v-1} \quad \text{with} \\ K(v) := (30(\log 15 + \log 2) / \log 2)^{v-1}.$$

Finally, taking now $m = m(\varepsilon)$ maximal s.t. (1) is fulfilled (note that $m(\varepsilon) < \infty$ by (6)), we obtain by (7) for the packing numbers $D(\varepsilon\nu(F), \mathcal{F}, d_\nu^{(1)})$ that

$$D(\varepsilon\nu(F), \mathcal{F}, d_\nu^{(1)}) \leq K(v) \varepsilon^{-(v-1)} |\log \varepsilon|^{v-1},$$

which implies the assertion of 4.3.17 according to the second inequality in 4.1.3. \square

REMARK.

The above method of proof is very interesting in its own right:

In order to verify that a certain situation holds true, an appropriate stochastic model is constructed within which it is shown that a proper event occurs with positive probability, from which one then infers the existence of the situation one was interested in.

As discovered by Alexander [Al87], there is an elegant way to pass from the upper bound in 4.3.17 w.r.t. L_1 -entropy (i.e. concerning $d_\nu^{(1)}$) to an analogous result for L_2 -entropy, i.e. concerning $d_\nu^{(2)}$ instead of $d_\nu^{(1)}$, where

$$d_\nu^{(2)}(f, g) := \left(\nu(|f - g|^2) \right)^{1/2}, \quad f, g \in \mathcal{F}.$$

This is done by using the elementary inequality

$$(4.3.18) \quad (a - b)^2 \leq 2|a^2 \operatorname{sign}(a) - b^2 \operatorname{sign}(b)| \quad \forall a, b \in \mathbb{R},$$

where

$$\operatorname{sign}(a) := \begin{cases} 1 & , \text{ if } a > 0 \\ 0 & , \text{ if } a = 0 \\ -1 & , \text{ if } a < 0 \end{cases}, \quad a \in \mathbb{R}.$$

4.3.19 Corollary ([Zi94], Cor. A5; see also Lemma 36 in section II.6 of [Po84] for a different method of proof).

Let \mathcal{F} be a VCGC with envelope F and graph region class \mathcal{R} . Then there exists a constant $0 < K'(v) < \infty$ depending only on $v \equiv V(\mathcal{R})$ such that for all measures ν on \mathcal{X} with $\nu(F^2) < \infty$

$$N(\varepsilon[\nu(F^2)]^{1/2}, \mathcal{F}, d_\nu^{(2)}) \leq K'(v)\varepsilon^{-4(v-1)} \quad \forall 0 < \varepsilon \leq 1.$$

PROOF. Let $\mathcal{F}' := \{f^2 \operatorname{sign}(f) : f \in \mathcal{F}\}$; then $\forall f, g \in \mathcal{F}$

$$\begin{aligned} d_\nu^{(2)}(f, g)^2 &= \nu(|f - g|^2) = \int_{\mathcal{X}} (f(x) - g(x))^2 \nu(dx) \\ &\stackrel{(4.3.18)}{\leq} 2 \int_{\mathcal{X}} |f^2(x) \operatorname{sign}(f(x)) - g^2(x) \operatorname{sign}(g(x))| \nu(dx) \\ &= 2d_\nu^{(1)}(f^2 \operatorname{sign}(f), g^2 \operatorname{sign}(g)), \quad \text{i.e.} \end{aligned}$$

$$\forall f, g \in \mathcal{F} \quad d_\nu^{(2)}(f, g)^2 \leq 2d_\nu^{(1)}(f', g')$$

with $f' := f^2 \operatorname{sign}(f)$ and $g' := g^2 \operatorname{sign}(g)$, whence, by the definition of covering numbers, one gets

$$(a) \quad N(\varepsilon[\nu(F^2)]^{1/2}, \mathcal{F}, d_\nu^{(2)}) \leq N(\frac{\varepsilon^2}{2}\nu(F^2), \mathcal{F}', d_\nu^{(1)}).$$

Now, also \mathcal{F}' is a VCGC with envelope F^2 and $V(\mathcal{R}') = V(\mathcal{R}) \equiv v$, where $\mathcal{R}' := \{G_{f'} : f' \in \mathcal{F}'\}$:

To see this, let $M' := \{(x_i, t_i), 1 \leq i \leq v\}$ be an arbitrary subset of $X \times \mathbb{R}$ with $|M'| = v$. Set $M := \{(x_i, |t_i|^{1/2} \operatorname{sign}(t_i)), 1 \leq i \leq v\}$ then $M \subset X \times \mathbb{R}$ and $|M| = v$. Since \mathcal{F} is a VCGC with $V(\mathcal{R}) = v$, there exists an $N \subset M$, $N = \{(x_i, |t_i|^{1/2} \operatorname{sign}(t_i)), i \in J \subset \{1, \dots, v\}\}$ such that

$$(b) \quad N \neq M \cap G_f \quad \forall f \in \mathcal{F}.$$

But (b) implies that $N' \neq M' \cap G_{f'}$ $\forall f' \in \mathcal{F}$, where $N' := \{(x_i, t_i) : i \in J\}$:

For, suppose to the contrary, that $N' = M' \cap G_{f'}$ for some $f' \in \mathcal{F}$, $f' = f^2 \text{ sign}(f)$, i.e. $\{(x_i, t_i) : i \in J\} = \{(x_i, t_i) : 1 \leq i \leq v\} \cap G_{f'}$; then, since

$$(x_i, t_i) \in G_{f'} \iff (x_i, |t_i|^{1/2} \text{sign}(t_i)) \in G_f,$$

we get $\{(x_i, |t_i|^{1/2} \text{sign}(t_i)), i \in J\} = \{(x_i, |t_i|^{1/2} \text{sign}(t_i)), 1 \leq i \leq v\} \cap G_f$, which contradicts (b).

Since M' was arbitrary with $|M'| = v$, \mathcal{F}' is a VCGC with $V(\mathcal{R}') \leq v$. In the same way one shows that $V(\mathcal{R}') < v$ would contradict the minimality of v and therefore $V(\mathcal{R}') = V(\mathcal{R})$.

Thus, by the NOTE following lemma 4.3.17 with $\varepsilon' := \varepsilon^2/2$ and $k := 2(v-1)$ we get

$$N(\varepsilon' \nu(F^2), \mathcal{F}', d_\nu^{(1)}) \leq K(v)(\varepsilon')^{-k} \quad \forall 0 < \varepsilon' \leq \frac{1}{2},$$

i.e. $N(\frac{\varepsilon^2}{2} \nu(F^2), \mathcal{F}', d_\nu^{(1)}) \leq 2^k K(v) \varepsilon^{-2k} \quad \forall 0 < \varepsilon \leq 1$, whence by (a)

$$N(\varepsilon[\nu(F^2)]^{1/2}, \mathcal{F}, d_\nu^{(2)}) \leq 2^k K(v) \varepsilon^{-4(v-1)} \quad \forall 0 < \varepsilon \leq 1. \quad \square$$

4.3.19 suggests the following definition (cf. [Al87] and [Va96], Condition (2.5.1), p.127):

4.3.20 Definition.

Let (X, \mathcal{X}) be a measurable space, \mathcal{F} a class of \mathcal{X} -measurable real-valued functions, and let $\mathcal{M}(X, F)$ be the set of all measures ν on \mathcal{X} with $\nu(F^2) < \infty$, where F is an envelope of \mathcal{F} . Then \mathcal{F} is said to have uniformly intrgrable L_2 -entropy, if

$$\int_0^\infty (\log N(\tau, \mathcal{F}))^{1/2} d\tau < \infty,$$

where $N(\tau, \mathcal{F}) := \sup_{\nu \in \mathcal{M}(X, F)} N(\tau[\nu(F^2)]^{1/2}, \mathcal{F}, d_\nu^{(2)})$.

4.3.21 Remark.

If \mathcal{F} has uniformly intrgrable L_2 -entropy, then $(\mathcal{F}, d_\nu^{(2)})$ is totally bounded for each $\nu \in \mathcal{M}(X, F)$.

(In fact, if $\int_0^\infty (\log N(\tau, \mathcal{F}))^{1/2} d\tau < \infty$, then for each $\nu \in \mathcal{M}(X, F)$ one has

$$(+) \quad N(\tau[\nu(F^2)]^{1/2}, \mathcal{F}, d_\nu^{(2)}) < \infty \quad \text{for } \lambda - a.a. \tau \in [0, \infty) \quad (\lambda \equiv \text{Lebesgue measure});$$

but, since $N(\varepsilon, \mathcal{F}, d_\nu^{(2)})$ is increasing as $\varepsilon \rightarrow 0$, (+) must hold for all $\tau \in [0, \infty)$)

Finally, it follows from 4.3.19 that each VCGC \mathcal{F} has uniformly intrgrable L_2 -entropy.

5 Some Fundamental Inequalities

5.1 Symmetrization Inequality

Before stating some of the inequalities needed later, the following definition concerning the concept of *independence in case of non-measurable maps*, i.e. of random quantities (rq's) is in order.

Guided by [Du83] and [Du84] (cf. also [Ho85]) we define as in [Zi94], Def. 1.2.1:

5.1.1 Definition.

Let $(\Omega, \mathcal{A}, \mathbb{P}) := (\prod_{j \in \mathbb{N}} \Omega_j, \otimes_{j \in \mathbb{N}} \mathcal{A}_j, \times_{j \in \mathbb{N}} \mathbb{P}_j)$ be the countable product of p -spaces $(\Omega_j, \mathcal{A}_j, \mathbb{P}_j)$, let V be an arbitrary set and $\eta_j : \Omega \rightarrow V$ be rq's of the form $\eta_j(\omega) = h_j(\omega_j)$ for $\omega = (\omega_1, \omega_2, \dots) \in \Omega, j \in \mathbb{N}$, with arbitrary rq's $h_j : \Omega_j \rightarrow V$.

Then the sequence $(\eta_j)_{j \in \mathbb{N}}$ is called *independent* (or, $\eta_j, j \in \mathbb{N}$, are said to be *independent rq's*).

The η_j 's are said to be *independent and identically distributed (iid)*, if in addition the p -spaces $(\Omega_j, \mathcal{A}_j, \mathbb{P}_j)$ as well as the rq's h_j defined on them are identical.

In the case $h_j = id_{\Omega_j}, j \in \mathbb{N}$, the sequence $(\eta_j)_{j \in \mathbb{N}}$ is said to be *canonically formed*.

NOTE: If the h_j 's (and so the η_j 's) are re's in $V = (V, \mathcal{V})$ (with an appropriate σ -field \mathcal{V}) then independence in the sense of 5.1.1 is equivalent with the usual concept of independence of re's.

In the following, when dealing with stochastic processes $\eta_j = (\eta_j(t))_{t \in T}$ (with common parameter space T), these processes will be considered as rq's with values in $V = \mathbb{R}^T$ or $V = l^\infty(T)$, respectively, and independence of stochastic processes is to be understood in the sense of 5.1.1.

To avoid measurability questions we will (if not stated otherwise) tacitly assume that the parameter spaces T are countable. (If not, one has to work with the “ $\mathbb{E}^*, \mathbb{P}^*$ -calculus”; see e.g. [Zi94] and [Va96].)

Note that, for countable T , the $\|\eta_j\| \equiv \|\eta_j\|_T := \sup_{t \in T} |\eta_j(t)|$ are re's in $(\bar{\mathbb{R}}_+, \bar{\mathcal{B}}_+)$ ($\bar{\mathbb{R}}_+ := \mathbb{R}_+ \cup \{\infty\}$) endowed with its Borel σ -field $\bar{\mathcal{B}}_+$, whence also $\|S_n\|_T, n \in \mathbb{N}$, are re's in $(\bar{\mathbb{R}}_+, \bar{\mathcal{B}}_+)$, where $S_n := \sum_{j \leq j(n)} \eta_j$.

To formulate the Symmetrization Inequality for independent stochastic processes $\eta_1, \dots, \eta_n, n \in \mathbb{N}$, indexed by a common parameter space T , we need the concept of a so-called *Rademacher sequence* $(\varepsilon_j)_{j \leq n}$, which means that the ε_j 's are iid rv's taking only the values $+1$ or -1 with equal probability, i.e. $\mathcal{L}\{\varepsilon_j\} = \frac{1}{2}\delta_{-1} + \frac{1}{2}\delta_1$ ($\delta_x \equiv$ Dirac measure at x).

Then, given (as in 5.1.1) $(\Omega', \mathcal{A}', \mathbb{P}') := (\prod_{j \leq n} \Omega'_j, \otimes_{j \leq n} \mathcal{A}'_j, \times_{j \leq n} \mathbb{P}'_j)$ and stochastic processes $\eta_j : \Omega' \rightarrow \mathbb{R}^T$ with $\eta_j(\omega') = h_j(\omega'_j)$ for $\omega' = (\omega'_1, \dots, \omega'_n) \in \Omega', 1 \leq j \leq n$, where $h_j : \Omega'_j \rightarrow \mathbb{R}^T$ are stochastic processes (indexed by T), let $(\Omega'', \mathcal{A}'', \mathbb{P}'') := (\{-1, 1\}^n, \otimes_{j \leq n} \mathcal{P}(\{-1, 1\}), \times_{j \leq n} \mathcal{L}\{\varepsilon_j\})$ and $(\Omega, \mathcal{A}, \mathbb{P}) := (\Omega' \times \Omega'', \mathcal{A}' \otimes \mathcal{A}'', \mathbb{P}' \times \mathbb{P}'')$ (i.e. $(\varepsilon_j)_{j \leq n}$ is thought to be canonically formed and independent of $(\eta_j)_{j \leq n}$, where η_1, \dots, η_n are independent processes). Denoting with $\mathbb{E}_{\omega'}, \mathbb{E}_{\omega''}$ and $\mathbb{E} \equiv \mathbb{E}_{\omega', \omega''}$ expectation of rv's defined on $(\Omega', \mathcal{A}', \mathbb{P}')$, $(\Omega'', \mathcal{A}'', \mathbb{P}'')$ and $(\Omega, \mathcal{A}, \mathbb{P})$, respectively, then in this setting the following result

holds true (cf. [Va96], Lemma 2.3.6 and [Zi94], Lemma 1.3.2):

5.1.2 Symmetrization Inequality.

Suppose that $\mathbb{E}_{\omega'}(|\eta_j(t)|) < \infty$ for all $t \in T$ and $1 \leq j \leq n$; then, for any convex and nondecreasing function $\psi : \mathbb{R}_+ \rightarrow \mathbb{R}_+$ (put, as usual $\psi(\infty) := \lim_{a \rightarrow \infty} \psi(a)$)

$$\mathbb{E}_{\omega'} \left(\psi \left(\sup_{t \in T} \left| \sum_{j \leq n} (\eta_j(t) - \mathbb{E}_{\omega'}(\eta_j(t))) \right| \right) \right) \leq \mathbb{E} \left(\psi \left(2 \sup_{t \in T} \left| \sum_{j \leq n} \varepsilon_j \eta_j(t) \right| \right) \right).$$

PROOF. Let $(\delta_1, \dots, \delta_n) \in \{-1, 1\}^n$ be arbitrary but fixed; consider the decomposition

$$\begin{aligned} (+) \quad \sum_{j \leq n} (\eta_j(t) - \mathbb{E}_{\omega'}(\eta_j(t))) &= \left(\sum_{\delta_j=1} \delta_j \eta_j(t) + \sum_{\delta_j=-1} \delta_j \mathbb{E}_{\omega'}(\eta_j(t)) \right) - \left(\sum_{\delta_j=-1} \delta_j \eta_j(t) + \sum_{\delta_j=1} \delta_j \mathbb{E}_{\omega'}(\eta_j(t)) \right). \end{aligned}$$

Since for any $M \subset \{1, \dots, n\}$ (with \mathbb{E}_M and $\mathbb{E}_{\mathfrak{C}M}$ denoting expectation of rv's indexed by M and $\mathfrak{C}M$, respectively)

$$\begin{aligned} &\mathbb{E}_{\omega'} \left(\psi \left(2 \sup_{t \in T} \left| \sum_{j \in M} \delta_j \eta_j(t) + \sum_{j \in \mathfrak{C}M} \delta_j \mathbb{E}_{\omega'}(\eta_j(t)) \right| \right) \right) \\ &= \mathbb{E}_M \left(\psi \left(2 \sup_{t \in T} \left| \mathbb{E}_{\mathfrak{C}M} \left(\sum_{j \in M} \delta_j \eta_j(t) + \sum_{j \in \mathfrak{C}M} \delta_j \eta_j(t) \right) \right| \right) \right) \\ &\stackrel{\substack{(\psi \text{ monotone} \\ \text{nondecreasing})}}{\leq} \mathbb{E}_M \left(\psi \left(\mathbb{E}_{\mathfrak{C}M} \left(2 \sup_{t \in T} \left| \sum_{j \leq n} \delta_j \eta_j(t) \right| \right) \right) \right) \\ &\stackrel{\substack{(\text{Jensen's} \\ \text{inequality})}}{\leq} \mathbb{E}_M \mathbb{E}_{\mathfrak{C}M} \left(\psi \left(2 \sup_{t \in T} \left| \sum_{j \leq n} \delta_j \eta_j(t) \right| \right) \right) \\ &\stackrel{\substack{(\text{Fubini})}}{=} \mathbb{E}_{\omega'} \left(\psi \left(2 \sup_{t \in T} \left| \sum_{j \leq n} \delta_j \eta_j(t) \right| \right) \right), \end{aligned}$$

we obtain with $M = M_1 := \{j \leq n : \delta_j = 1\}$ and $M = M_2 := \{j \leq n : \delta_j = -1\}$, respectively, by the inequality

$$\psi(a+b) \leq \frac{1}{2}\psi(2a) + \frac{1}{2}\psi(2b) \quad \forall a, b \in \bar{\mathbb{R}}_+$$

(valid since ψ is convex), that

$$\begin{aligned} &\mathbb{E}_{\omega'} \left(\psi \left(\sup_{t \in T} \left| \sum_{j \leq n} (\eta_j(t) - \mathbb{E}_{\omega'}(\eta_j(t))) \right| \right) \right) \stackrel{(+)}{\leq} \\ &\mathbb{E}_{\omega'} \left(\psi \left(\sup_{t \in T} \left| \sum_{j \in M_1} \delta_j \eta_j(t) + \sum_{j \in \mathfrak{C}M_1} \delta_j \mathbb{E}_{\omega'}(\eta_j(t)) \right| + \sup_{t \in T} \left| \sum_{j \in M_2} \delta_j \eta_j(t) + \sum_{j \in \mathfrak{C}M_2} \delta_j \mathbb{E}_{\omega'}(\eta_j(t)) \right| \right) \right) \leq \\ &\frac{1}{2} \mathbb{E}_{\omega'} \left(\psi \left(2 \sup_{t \in T} \left| \sum_{j \in M_1} \delta_j \eta_j(t) + \sum_{j \in \mathfrak{C}M_1} \delta_j \mathbb{E}_{\omega'}(\eta_j(t)) \right| \right) \right) + \frac{1}{2} \mathbb{E}_{\omega'} \left(\psi \left(2 \sup_{t \in T} \left| \sum_{j \in M_2} \delta_j \eta_j(t) + \sum_{j \in \mathfrak{C}M_2} \delta_j \mathbb{E}_{\omega'}(\eta_j(t)) \right| \right) \right) \leq \\ &\mathbb{E}_{\omega'} \left(\psi \left(2 \sup_{t \in T} \left| \sum_{j \leq n} \delta_j \eta_j(t) \right| \right) \right). \end{aligned}$$

Since $(\delta_1, \dots, \delta_n)$ was arbitrary, we get

$$\begin{aligned} \mathbb{E}_{\omega'} \left(\psi \left(\sup_{t \in T} \left| \sum_{j \leq n} (\eta_j(t) - \mathbb{E}_{\omega'}(\eta_j(t))) \right| \right) \right) &\leq \\ \mathbb{E}_{\omega''} \mathbb{E}_{\omega'} \left(\psi \left(2 \sup_{t \in T} \left| \sum_{j \leq n} \varepsilon_j \eta_j(t) \right| \right) \right) &\stackrel{(\text{Fubini})}{=} \\ \mathbb{E} \left(\psi \left(2 \sup_{t \in T} \left| \sum_{j \leq n} \varepsilon_j \eta_j(t) \right| \right) \right). & \quad \square \end{aligned}$$

5.2 Maximal Inequality for Rademacher Averages

The maximal inequality for Rademacher Averages (see 5.2.3 below) is based on ideas exposted by Pisier [Pi83]. The present proofs are mainly due to Klaus Ziegler [Zi94]. The following lemma is a special case of (3.2) in combination with (3.1) in [Po90]:

5.2.1 Lemma.

Given a Rademacher sequence $\varepsilon_1, \dots, \varepsilon_N$ and given a finite and non empty subset M of \mathbb{R}^N , there exists for each $1 \leq p < \infty$ a universal constant $0 < K_p < \infty$ such that

$$\mathbb{E}^{\frac{1}{p}} \left(\max_{x \in M} \left| \sum_{j \leq N} \varepsilon_j x_j \right|^p \right) \leq K_p (1 + \log |M|)^{\frac{1}{2}} \cdot \max_{x \in M} \left(\sum_{j \leq N} x_j^2 \right)^{\frac{1}{2}},$$

where $|M|$ denotes the cardinality of M and $x = (x_1, \dots, x_N)$.

Note that for $|M| = 1$ this is just one of Khintchine's inequalities; see Ledoux and Talagrand [Le91], Lemma 4.1, p.91.

For the proof of 5.2.1 the following proposition is used which is but a reformulation of Lemma 1.6 in [Pi83] for the present purposes.

5.2.2 Proposition.

Let ξ_1, \dots, ξ_n be arbitrary nonnegative rv's and Φ be a strictly increasing, nonnegative, convex function defined on $[0, \infty)$ such that there are constants $0 < c_i < \infty$, $1 \leq i \leq n$, and $0 < c < \infty$ with $\mathbb{E}(\Phi(c_i^{-1} \xi_i)) \leq c$ for all $1 \leq i \leq n$. Then

$$\mathbb{E} \left(\max_{1 \leq i \leq n} \xi_i \right) \leq \Phi^{-1}(cn) \cdot \max_{1 \leq i \leq n} c_i$$

(Φ^{-1} being the inverse function of Φ).

PROOF.

$$\begin{aligned}
\Phi\left(\mathbb{E}\left(\max_{1 \leq i \leq n} \xi_i / \max_{1 \leq i \leq n} c_i\right)\right) &\leq \Phi\left(\mathbb{E}\left(\max_{1 \leq i \leq n} (\xi_i / c_i)\right)\right) \stackrel{\text{(Jensen's inequality)}}{\leq} \\
&\mathbb{E}\left(\Phi\left(\max_{1 \leq i \leq n} (\xi_i / c_i)\right)\right) = \mathbb{E}\left(\max_{1 \leq i \leq n} \Phi(\xi_i / c_i)\right) \leq \\
&\mathbb{E}\left(\sum_{i \leq n} \Phi(\xi_i / c_i)\right) = \sum_{i \leq n} \mathbb{E}(\Phi(\xi_i / c_i)) \leq c n.
\end{aligned}$$

Applying Φ^{-1} to both sides yields the assertion. \square

PROOF of 5.2.1. We show at first that the *Rademacher average* on the l.h.s of the stated inequality in 5.2.1 can be dominated by a so-called *Gaussian average*, to which 5.2.2 will be applied.

For this, let g_1, \dots, g_N be iid rv's with $\mathcal{L}\{g_i\} = \mathcal{N}(0, 1)$ being independent of $\varepsilon_1, \dots, \varepsilon_N$. Note that

$$(+)\quad \mathcal{L}\{(\varepsilon_1 |g_1|, \dots, \varepsilon_N |g_N|)\} = \mathcal{L}\{(g_1, \dots, g_N)\}.$$

Let $\mu := \mathbb{E}(|g_1|)$; then

$$\begin{aligned}
&\mathbb{E}\left(\max_{x \in M} \left| \sum_{j \leq N} \varepsilon_j x_j \right|^p\right) = \\
&\mu^{-p} \mathbb{E}\left(\max_{x \in M} \left| \sum_{j \leq N} \varepsilon_j \mathbb{E}(|g_j|) x_j \right|^p\right) = \mu^{-p} \mathbb{E}\left(\max_{x \in M} \left| \sum_{j \leq N} \varepsilon_j \mathbb{E}(|g_j| \mid \varepsilon_1, \dots, \varepsilon_N) x_j \right|^p\right) = \\
&\mu^{-p} \mathbb{E}\left(\max_{x \in M} \left| \mathbb{E}\left(\sum_{j \leq N} \varepsilon_j |g_j| x_j \mid \varepsilon_1, \dots, \varepsilon_N\right) \right|^p\right) \stackrel{\text{(Jensen's inequality)}}{\leq} \mu^{-p} \mathbb{E}\left(\max_{x \in M} \mathbb{E}\left(\left| \sum_{j \leq N} \varepsilon_j |g_j| x_j \right|^p \mid \varepsilon_1, \dots, \varepsilon_N\right)\right) \leq \\
&\mu^{-p} \mathbb{E}\left(\mathbb{E}\left(\max_{x \in M} \left| \sum_{j \leq N} \varepsilon_j |g_j| x_j \right|^p \mid \varepsilon_1, \dots, \varepsilon_N\right)\right) = \\
&\mu^{-p} \mathbb{E}\left(\max_{x \in M} \left| \sum_{j \leq N} \varepsilon_j |g_j| x_j \right|^p\right) \stackrel{(+)}{=} \mu^{-p} \mathbb{E}\left(\max_{x \in M} \left| \sum_{j \leq N} g_j x_j \right|^p\right).
\end{aligned}$$

Now, let $\Phi'(u) := \exp(u^{2/p})$ for $u \in [0, \infty)$ and

$$\Phi(u) := \begin{cases} 1 + \frac{\Phi'(u_p) - 1}{u_p} & , \text{ for } 0 \leq u \leq u_p \\ \Phi'(u) & , \text{ for } u > u_p \end{cases},$$

where $u_p := \left(\frac{p}{2}\right)^{p/2}$; then

(\star) $\Phi : \mathbb{R}_+ \rightarrow \mathbb{R}_+$ is a strictly increasing, nonnegative, convex function with $\Phi \leq \Phi'$, and

($\star\star$) $\forall v \in \mathbb{R}_+ \quad \Phi^{-1}(v) \leq u_p + (\log v)^{p/2}$.

On the other hand, assigning to each $x = (x_1, \dots, x_N) \in M$ the rv $\xi_x := \sum_{j \leq N} g_j x_j$, we have for each $x \in M$ that $\mathcal{L}\{\xi_x\} = \mathcal{N}(0, c_x^2)$ with $c_x^2 := (\sum_{j \leq N} x_j^2)$, and

$$\begin{aligned} & \mathbb{E}\left(\Phi(|\xi_x|^p / 2^p c_x^p)\right) \stackrel{(\Phi \leq \Phi')}{\leq} \\ & \mathbb{E}\left(\Phi'(|\xi_x|^p / 2^p c_x^p)\right) \stackrel{(\text{by def. of } \Phi')}{=} \mathbb{E}\left(\exp(\xi_x^2 / 4c_x^2)\right) \stackrel{(\mathcal{L}\{\xi_x/c_x\} = \mathcal{N}(0,1))}{=} \\ & (2\pi)^{-1/2} \int_{\mathbb{R}} e^{u^2/4} e^{-u^2/2} du = (2\pi)^{-1/2} \int_{\mathbb{R}} e^{-u^2/4} du \stackrel{(u:=\sqrt{2}v)}{=} \\ & \sqrt{2} (2\pi)^{-1/2} \int_{\mathbb{R}} e^{-v^2/2} dv = \sqrt{2}. \end{aligned}$$

Thus 5.2.2 can be applied (cf. (\star)) with $|\xi_x|^p, x \in M$, instead of $\xi_i, 1 \leq i \leq n$, and with $2^p c_x^p, x \in M$, instead of $c_i, 1 \leq i \leq n$, where $n = |M|$ and $c := \sqrt{2}$.

Hence by 5.2.2 it follows that

$$\begin{aligned} & \mathbb{E}\left(\max_{x \in M} \left| \sum_{j \leq N} g_j x_j \right|^p\right) = \\ & \mathbb{E}\left(\max_{x \in M} |\xi_x|^p\right) \leq \Phi^{-1}(\sqrt{2}|M|) \max_{x \in M} (2^p c_x^p) \stackrel{(\star\star)}{\leq} \\ & \left(u_p + (\log(\sqrt{2}|M|))^{p/2}\right) \cdot \max_{x \in M} (2^p c_x^p) \stackrel{(\text{by def. of } c_x)}{=} \\ & 2^p u_p \max_{x \in M} \left(\sum_{j \leq N} x_j^2\right)^{p/2} + 2^p \left(\log \sqrt{2} + \log |M|\right)^{p/2} \max_{x \in M} \left(\sum_{j \leq N} x_j^2\right)^{p/2} \leq \\ & \left(2^p u_p + 2^p (1 + \log |M|)^{p/2}\right) \cdot \max_{x \in M} \left(\sum_{j \leq N} x_j^2\right)^{p/2} \leq \\ & \bar{K}_p^p (1 + \log |M|)^{p/2} \cdot \max_{x \in M} \left(\sum_{j \leq N} x_j^2\right)^{p/2} \quad \text{with } \bar{K}_p^p := 2^p (u_p + 1). \end{aligned}$$

Since $\mathbb{E}^{1/p} \left(\max_{x \in M} \left| \sum_{j \leq N} \varepsilon_j x_j \right|^p \right) \leq \mu^{-1} \mathbb{E}^{1/p} \left(\max_{x \in M} \left| \sum_{j \leq N} g_j x_j \right|^p \right)$, as shown above, the assertion of 5.2.1 holds true with $K_p := \mu^{-1} \bar{K}_p$. \square

The following maximal inequality will be an essential tool for proving a ULLN for RMP's in section 6.1 below. As we shall see, it is an easily to be shown consequence of 5.2.1:

5.2.3 Maximal Inequality for Rademacher Averages.

Given any $x_j \in \mathbb{R}^T, 1 \leq j \leq N, N \in \mathbb{N}$, let

$$d_1(s, t) := \sum_{j \leq N} |x_j(s) - x_j(t)|, \quad s, t \in T.$$

Then, for each $1 \leq p < \infty$, there exists a universal constant $0 < K_p < \infty$ such that for any Rademacher sequence $\varepsilon_1, \dots, \varepsilon_N$ and for all $\gamma > 0$

$$\mathbb{E}^{1/p} \left(\sup_{t \in T} \left| \sum_{j \leq N} \varepsilon_j x_j(t) \right|^p \right) \leq \gamma + K_p (1 + H(\gamma, T, d_1))^{1/2} \cdot \sup_{t \in T} \left(\sum_{j \leq N} x_j^2(t) \right)^{1/2}$$

(where $H(\cdot, T, d_1)$ denotes the metric entropy of $T = (T, d_1)$ as defined in 4.1.1).

PROOF. Given any $\gamma > 0$, assume w.l.o.g. that $N(\gamma, T, d_1) < \infty$; then (cf. the definition of $N(\cdot, T, d_1)$ in 4.1.1) there exists a subset T' of T with $|T'| = N(\gamma, T, d_1)$ such that for each $t \in T$ there exists a $u(t) \in T'$ with $d_1(t, u(t)) \leq \gamma$.

Then we get

$$\begin{aligned} & \mathbb{E}^{1/p} \left(\sup_{t \in T} \left| \sum_{j \leq N} \varepsilon_j x_j(t) \right|^p \right) \stackrel{\text{(Minkowski's Ineq.)}}{\leq} \\ & \mathbb{E}^{1/p} \left(\sup_{t \in T} \left| \sum_{j \leq N} \varepsilon_j (x_j(t) - x_j(u(t))) \right|^p \right) + \mathbb{E}^{1/p} \left(\sup_{t \in T'} \left| \sum_{j \leq N} \varepsilon_j x_j(t) \right|^p \right) \stackrel{5.2.1}{\leq} \\ & \sup_{t \in T} \left| \sum_{j \leq N} |x_j(t) - x_j(u(t))| \right| + K_p (1 + \log |T'|)^{1/2} \sup_{t \in T} \left(\sum_{j \leq N} x_j^2(t) \right)^{1/2} \leq \\ & \gamma + K_p (1 + H(\gamma, T, d_1))^{1/2} \cdot \sup_{t \in T} \left(\sum_{j \leq N} x_j^2(t) \right)^{1/2}. \end{aligned}$$

□

5.3 Hoffmann-Jørgensen Inequality

To our knowledge, the Hoffmann-Jørgensen Inequality was originally proved implicitly in [Ho74], Theorem 3.1, for sums of independent and symmetric Banachspace-valued r.v.'s (cf. [Le91], Section 6.2).

Here we will consider as before independent (in the sense of 5.1.1) stochastic processes $\eta_j = (\eta_j(t))_{t \in T}$, $j \in \mathbb{N}$, indexed by an arbitrary parameter space T (supposed to be countable for simplicity to avoid measurability considerations). The η_j 's will be viewed as r.v.'s with values in \mathbb{R}^T or $l^\infty(T)$, respectively, and $\|\eta\|$ or $\|\sum_{j \leq n} \varepsilon_j \eta_j\|$ denotes the $\sup_{t \in T} |\eta(t)|$ or $\sup_{t \in T} |\sum_{j \leq n} \varepsilon_j \eta_j|$, respectively.

5.3.1 Hoffmann-Jørgensen Inequality

(Cf. [Va96], A.1.5 and [Zi94], Corollary 2.1.3).

Let $\eta_j = (\eta_j(t))_{t \in T}$, $j \in \mathbb{N}$, be a sequence of independent stochastic processes with common parameter space T and $(\varepsilon_j)_{j \in \mathbb{N}}$ be a canonically formed Rademacher sequence which is independent of $(\eta_j)_{j \in \mathbb{N}}$ (cf.

section 5.1). Let $\Psi : \mathbb{R}_+ \rightarrow \mathbb{R}_+$ be a nondecreasing function which is absolutely continuous on each interval $[0, a]$, $a > 0$, and which satisfies the so-called *Orlicz condition*

$$\Psi(2x) \leq C\Psi(x) \quad \text{for all } x \in \mathbb{R}_+ \quad \text{and some } 1 \leq C < \infty$$

(think e.g. of $\Psi(x) = x^p$); then for each $n \in \mathbb{N}$ (as before, we put $\Psi(\infty) := \lim_{a \rightarrow \infty} \Psi(a)$)

$$\mathbb{E}\left(\Psi\left(\left\|\sum_{j \leq n} \varepsilon_j \eta_j\right\|\right)\right) \leq 2C^2 \mathbb{E}\left(\max_{j \leq n} \Psi(\|\eta_j\|)\right) + 2C^2 \Psi(s_n)$$

with $s_n := \inf\{s > 0 : \mathbb{P}(\|\sum_{j \leq n} \varepsilon_j \eta_j\| > s) \leq (4C^2)^{-1}\}$.

NOTE: This inequality will be an essential tool in proving a uniform law of large numbers (ULLN) for Random Measure Processes in the following section 6.1. It will be applied there with $\Psi(x) := x^p$, $1 \leq p < \infty$. In such a case one can infer L_p -convergence of $\sum_{j \leq n} \varepsilon_j \eta_{nj}$ to zero from its \mathbb{P} -stochastic convergence to zero, provided that the η_{nj} 's are asymptotically negligible in the sense that $\lim_{n \rightarrow \infty} \mathbb{E}(\max_{j \leq n} \|\eta_{nj}\|^p) = 0$, where the latter is e.g. fulfilled, if the $\|\eta_{nj}\|$'s are bounded by some δ_n with $\lim_{n \rightarrow \infty} \delta_n = 0$.

6 Uniform Laws of Large Numbers (ULLN)

6.1 A ULLN for RMP's

Let again $X = (X, \mathcal{X})$ be an arbitrary measurable space and denote with $M(X)$ the space of all p-measures w on \mathcal{X} , equipped with the smallest σ -field \mathcal{M} such that all the maps $w \mapsto w(B), B \in \mathcal{X}$, are measurable.

Let \mathcal{F} be a class of \mathcal{X} -measurable functions $f : X \rightarrow \mathbb{R}$ with \mathcal{X} -measurable envelope $F : X \rightarrow \mathbb{R}$ (supposed to be countable for simplicity to avoid measurability considerations). Let, as in section 3, $(w_{nj})_{1 \leq j \leq j(n), n \in \mathbb{N}}$ be a triangular array of *random* p-measures on \mathcal{X} , considered as re's in $(M(X), \mathcal{M})$, and let $(\xi_{nj})_{1 \leq j \leq j(n), n \in \mathbb{N}}$ be a triangular array of real-valued rv's (i.e. re's in $(\mathbb{R}, \mathcal{B})$), where $j(n) \rightarrow 0$ as $n \rightarrow \infty$.

We are going to present a ULLN for RMP's $S_n = (S_n(f))_{f \in \mathcal{F}}$ with

$$(6.1.1) \quad S_n(f) := \sum_{j \leq j(n)} w_{nj}(f) \cdot \xi_{nj}, \quad f \in \mathcal{F},$$

as introduced in section 3.1, where, as already remarked there, we do assume (cf. 5.1.1) that the processes $(w_{nj}(f) \cdot \xi_{nj})_{f \in \mathcal{F}}$ are defined via coordinate projections on the product p-space

$$(\Omega, \mathcal{A}, \mathbb{P}) := \left(\prod_{\mathbb{N}} \left(\prod_{j \leq j(n)} (M(X) \times \mathbb{R}) \right), \otimes_{\mathbb{N}} \left(\otimes_{j \leq j(n)} (\mathcal{M} \otimes \mathcal{B}) \right), \times_{\mathbb{N}} \left(\times_{j \leq j(n)} \mathcal{L}\{(w_{nj}, \xi_{nj})\} \right) \right),$$

whence for all $n \in \mathbb{N}$ the sequence

$$(w_{n1}, \xi_{n1}), \dots, (w_{nj(n)}, \xi_{nj(n)})$$

is a sequence of independent but not necessarily identically distributed pairs of re's in $(M(X) \times \mathbb{R}, \mathcal{M} \otimes \mathcal{B})$, i.e. the laws $\mathcal{L}\{(w_{nj}, \xi_{nj})\}$ need not be identical; also dependence within each pair is allowed.

(Note that in the notation of definition 5.1.1 we have now that

$$\Omega \ni \omega \mapsto \eta_{nj}(\omega) = h_{nj}(\omega_{nj}) := h_{nj}((w_{nj}, \xi_{nj})) := (w_{nj}(f) \cdot \xi_{nj})_{f \in \mathcal{F}} \in V := \mathbb{R}^{\mathcal{F}}.)$$

In order to formulate our ULLN we need some more notation:

Given $S_n = (S_n(f))_{f \in \mathcal{F}}$ with $S_n(f)$ as in (6.1.1), let for any $\delta > 0$

$$\mu_{n\delta} := \sum_{j \leq j(n)} w_{nj} \cdot |\xi_{nj}| \cdot I(w_{nj}(F) | \xi_{nj}| \leq \delta),$$

and let $\bar{d}_{\mu_{n\delta}}^{(1)}$ be the *random* L_1 -pseudometric on \mathcal{F} defined by

$$\bar{d}_{\mu_{n\delta}}^{(1)}(f, g) := \sum_{j \leq j(n)} |w_{nj}(f) - w_{nj}(g)| \cdot |\xi_{nj}| \cdot I(w_{nj}(F) | \xi_{nj}| \leq \delta)$$

for $f, g \in \mathcal{F}$. Finally, for any $\tau > 0$, let $N(\tau, \mathcal{F}, \bar{d}_{\mu_{n\delta}}^{(1)})$ be the *random* covering number of $(\mathcal{F}, \bar{d}_{\mu_{n\delta}}^{(1)})$ (see the definition 4.1.1).

Then we have the following result (cf. [Gae98], Theorem 2.1):

6.1.2 THEOREM (ULLN for RMP's).

Assume that (6.1.3) – (6.1.5) hold, where (for $1 \leq p < \infty$)

$$(6.1.3) \quad \lim_{n \rightarrow \infty} \sum_{j \leq j(n)} \mathbb{E}^{\frac{1}{p}} \left(w_{nj}(F)^p \cdot |\xi_{nj}|^p \cdot I(w_{nj}(F)|\xi_{nj}| > \delta) \right) = 0 \quad \text{for all } \delta > 0$$

$$(6.1.4) \quad \sup_{n \in \mathbb{N}} \sum_{j \leq j(n)} \mathbb{E} \left(w_{nj}(F) \cdot |\xi_{nj}| \cdot I(w_{nj}(F)|\xi_{nj}| \leq \delta_1) \right) < \infty \quad \text{for some } \delta_1 > 0$$

$$(6.1.5) \quad \text{For all } \tau > 0 \text{ there exists } \delta \equiv \delta(\tau) > 0 \text{ such that} \\ (N(\tau \cdot \mu_{n\delta}(F), \mathcal{F}, \bar{d}_{\mu_{n\delta}}^{(1)}))_{n \in \mathbb{N}} \text{ is stochastically bounded.}$$

Then

$$(6.1.6) \quad \sup_{f \in \mathcal{F}} |S_n(f) - \mathbb{E}(S_n(f))| \xrightarrow{L_p} 0,$$

where $\xrightarrow{L_p}$ denotes convergence w.r.t. the L_p -metric.

$((N(\tau \cdot \mu_{n\delta}(F), \mathcal{F}, \bar{d}_{\mu_{n\delta}}^{(1)}))_{n \in \mathbb{N}}$ stochastically bounded means that for all $\rho > 0$ there exists an $M \equiv M(\tau, \rho) < \infty$ such that

$$\limsup_{n \rightarrow \infty} \mathbb{P}^* \left(N(\tau \cdot \mu_{n\delta}(F), \mathcal{F}, \bar{d}_{\mu_{n\delta}}^{(1)}) > M \right) < \rho.)$$

PROOF. Concerning (6.1.6) we remark that by (6.1.3) we also have (since $\|\cdot\|_1 \leq \|\cdot\|_p$)

$$\lim_{n \rightarrow \infty} \sum_{j \leq j(n)} \mathbb{E} \left(w_{nj}(F) \cdot |\xi_{nj}| \cdot I(w_{nj}(F)|\xi_{nj}| > \delta) \right) = 0 \quad \forall \delta > 0,$$

whence by (6.1.4)

$$\sup_{n \in \mathbb{N}} \sum_{j \leq j(n)} \mathbb{E} \left(w_{nj}(F) \cdot |\xi_{nj}| \right) < \infty,$$

and therefore $\mathbb{E}(|S_n(f)|) < \infty \quad \forall n \in \mathbb{N}$ and $\forall f \in \mathcal{F}$.

Now, by the Symmetrization Inequality 5.1.2 (applied with $\Psi(x) := x^p, x \in \mathbb{R}_+$), it suffices to show that

$$\lim_{n \rightarrow \infty} \mathbb{E} \left(\sup_{f \in \mathcal{F}} \left| \sum_{j \leq j(n)} \varepsilon_j w_{nj}(f) \xi_{nj} \right|^p \right) = 0$$

where $(\varepsilon_j)_{j \in \mathbb{N}}$ is a canonically formed Rademacher sequence which is independent of both arrays (w_{nj}) and (ξ_{nj}) .

Next, by (6.1.3) there exists a sequence $(\delta_n)_{n \in \mathbb{N}}$ of positive real numbers with $\delta_n \rightarrow 0$ and

$$\lim_{n \rightarrow \infty} \sum_{j \leq j(n)} \mathbb{E}^{\frac{1}{p}} \left(\mu_{nj}(F)^p \cdot I(\mu_{nj}(F) > \delta_n) \right) = 0,$$

where we put $\mu_{nj} := w_{nj} \cdot |\xi_{nj}|$ for short. Hence it suffices to show that

$$\lim_{n \rightarrow \infty} \mathbb{E}(\sup_{f \in \mathcal{F}} |S_{n\delta_n}(f)|^p) = 0,$$

where $S_{n\delta_n}(f) := \sum_{j \leq j(n)} \varepsilon_j w_{nj}(f) \xi_{nj} \cdot I(\mu_{nj}(F) \leq \delta_n)$.

But, since the summands of $S_{n\delta_n}(f)$ are bounded by δ_n (with $\delta_n \rightarrow 0$ as $n \rightarrow \infty$), it follows by application of Hoffmann-Jørgensen's Inequality 5.3.1 (with $\Psi(x) := x^p$, $x \in \mathbb{R}_+$) that it suffices to verify

$$(a) \quad \sup_{f \in \mathcal{F}} |S_{n\delta_n}(f)| \xrightarrow{\mathbb{P}} 0.$$

To prove (a), let $\beta > 0$ and $\varepsilon > 0$ be arbitrary but fixed. Let (cf. (6.1.4))

$$C := \sup_{n \in \mathbb{N}} \sum_{j \leq j(n)} \mathbb{E}(\mu_{nj}(F) \cdot I(\mu_{nj}(F) \leq \delta_1)).$$

Choose $\tau := \varepsilon\beta/2C$ and take $\delta = \delta(\tau)$ according to (6.1.5).

Now, for $\rho := \varepsilon/2$, let $M = M(\tau, \rho) > 0$ be such that for $A_n := \{N(\tau\mu_{n\delta}(F), \mathcal{F}, \bar{d}_{\mu_{n\delta}}^{(1)})^* > M\}$ we have by (6.1.5) that $\limsup_{n \rightarrow \infty} \mathbb{P}(A_n) < \rho$ where the star (*) denotes the measurable cover function (cf. (2.3.17)). Then, by Markov's Inequality and Fubini's theorem it follows that

$$(b) \quad \mathbb{P}(\sup_{f \in \mathcal{F}} |S_{n\delta_n}(f)| > \beta) \leq \mathbb{P}(A_n) + \beta^{-1} \mathbb{E}(1_{\mathbf{c}A_n} \mathbb{E}_\varepsilon(\sup_{f \in \mathcal{F}} |S_{n\delta_n}(f)|)),$$

where \mathbb{E}_ε denotes integration w.r.t. the Rademacher sequence.

Now, for n large enough such that $\delta_n \leq \delta$ and $\delta_n \leq \delta_1$ (δ_1 as in (6.1.4)) we obtain by the Maximal Inequality for Rademacher Averages with a universal constant $0 < K_1 < \infty$ that

$$\begin{aligned} & \mathbb{E}_\varepsilon(\sup_{f \in \mathcal{F}} |S_{n\delta_n}(f)|) \\ & \leq \tau\mu_{n\delta}(F) + \\ & \quad K_1(1 + N(\tau\mu_{n\delta}(F), \mathcal{F}, \bar{d}_{\mu_{n\delta}}^{(1)}))^{\frac{1}{2}} \cdot \sup_{f \in \mathcal{F}} \left| \sum_{j \leq j(n)} w_{nj}^2(f) \cdot \xi_{nj}^2 \cdot I(\mu_{nj}(F) \leq \delta_n) \right|^{\frac{1}{2}} \\ & \leq \tau\mu_{n\delta}(F) + \\ & \quad \delta_n^{\frac{1}{2}} K_1(1 + N(\tau\mu_{n\delta}(F), \mathcal{F}, \bar{d}_{\mu_{n\delta}}^{(1)}))^{\frac{1}{2}} \left(\sum_{j \leq j(n)} \mu_{nj}(F) \cdot I(\mu_{nj}(F) \leq \delta_1) \right)^{\frac{1}{2}}. \end{aligned}$$

(Actually the Maximal Inequality even holds with $\log N(\tau\mu_{n\delta}(F), \mathcal{F}, \bar{d}_{\mu_{n\delta}}^{(1)})$ instead of $N(\tau\mu_{n\delta}(F), \mathcal{F}, \bar{d}_{\mu_{n\delta}}^{(1)})$.)

So by definition of A_n it follows that for large enough n

$$(c) \quad \begin{aligned} & \mathbb{E}(1_{\mathbf{c}A_n} \mathbb{E}_\varepsilon(\sup_{f \in \mathcal{F}} |S_{n\delta_n}(f)|)) \leq \\ & \tau \mathbb{E}(\mu_{n\delta}(F)) + \delta_n^{\frac{1}{2}} K_1(1 + M)^{\frac{1}{2}} \mathbb{E}^{\frac{1}{2}}(\sum_{j \leq j(n)} \mu_{nj}(F) \cdot I(\mu_{nj}(F) \leq \delta_1)). \end{aligned}$$

Now, observe that $\mu_{n\delta} \leq \sum_{j \leq j(n)} \mu_{nj} \cdot I(\mu_{nj}(F) \leq \delta_1) + \sum_{j \leq j(n)} \mu_{nj} \cdot I(\mu_{nj}(F) > \delta_1)$ whence by (6.1.3) we have

$$(d) \quad \limsup_{n \rightarrow \infty} \mathbb{E}(\mu_{n\delta}(F)) \leq C + \limsup_{n \rightarrow \infty} \sum_{j \leq j(n)} \mathbb{E}^{\frac{1}{p}}(\mu_{nj}(F)^p \cdot I(\mu_{nj}(F) > \delta_1)) = C.$$

Hence we obtain by (b) – (d) that

$$\limsup_{n \rightarrow \infty} \mathbb{P}(\sup_{f \in \mathcal{F}} |S_{n\delta_n}(f)| > \beta) \leq \rho + \beta^{-1} \tau C = \varepsilon$$

by the choice of ρ and τ . Since ε and β were arbitrary, this implies (a). \square

NOTE: Condition (6.1.5) in the theorem can be replaced by (6.1.5)'

$$(6.1.5)' \quad \text{For all } \tau > 0 \text{ there exists } \delta \equiv \delta(\tau) > 0 \text{ such that} \\ (N(\tau, \mathcal{F}, \bar{d}_{\mu_{n\delta}}^{(1)}))_{n \in \mathbb{N}} \text{ is stochastically bounded.}$$

Indeed, following the proof of theorem 6.1.2 up to (b) now with $\tau := \varepsilon\beta/2$ and $A_n := \{N(\tau, \mathcal{F}, \bar{d}_{\mu_{n\delta}}^{(1)})^* > M\}$, the Maximal Inequality for Rademacher Averages now gives

$$\mathbb{E}_\varepsilon(\sup_{f \in \mathcal{F}} |S_{n\delta_n}(f)|) \leq \\ \tau + K_1(1 + N(\tau, \mathcal{F}, \bar{d}_{\mu_{n\delta}}^{(1)}))^{\frac{1}{2}} \cdot \sup_{f \in \mathcal{F}} \left| \sum_{j \leq j(n)} w_{nj}^2(f) \cdot \xi_{nj}^2 \cdot I(\mu_{nj}(F) \leq \delta_n) \right|^{\frac{1}{2}}.$$

The result then follows as above.

6.1.7 Remark.

Since for RMP's we did tacitly assume (cf. section 3.1) measurability and finiteness of $w_{nj}(F)$ for all $1 \leq j \leq j(n)$ and $n \in \mathbb{N}$, the same is true for the random measures $\mu_{n\delta}$, whence $\mu_{n\delta}(F) < \infty$ for all $n \in \mathbb{N}$ and $\delta > 0$. Therefore, it follows from 4.3.17 that in case of VCGC's \mathcal{F} , for each $\tau > 0$ there exists a constant $C = C(\tau)$, $0 < C < \infty$, such that (note that $\bar{d}_{\mu_{n\delta}}^{(1)}(f, g) \leq d_{\mu_{n\delta}}^{(1)} := \mu_{n\delta}(|f - g|)$)

$$\sup_{n \in \mathbb{N}} N(\tau \cdot \mu_{n\delta}(F), \mathcal{F}, \bar{d}_{\mu_{n\delta}}^{(1)}) \leq C,$$

whence the condition (6.1.5) is automatically fulfilled for VCGC's \mathcal{F} with envelope F .

Thus, from Theorem 6.1.2 we get

6.1.8 Corollary.

Let \mathcal{F} be a countable VCGC with envelope F . Assume (6.1.3) and (6.1.4), i.e. (for $1 \leq p < \infty$)

$$\lim_{n \rightarrow \infty} \sum_{j \leq j(n)} \mathbb{E}^{\frac{1}{p}}(w_{nj}(F)^p \cdot |\xi_{nj}|^p \cdot I(w_{nj}(F)|\xi_{nj}| > \delta)) = 0 \quad \text{for all } \delta > 0, \text{ and}$$

$$\sup_{n \in \mathbb{N}} \sum_{j \leq j(n)} \mathbb{E}(w_{nj}(F) \cdot |\xi_{nj}| \cdot I(w_{nj}(F)|\xi_{nj}| \leq \delta_1)) < \infty \quad \text{for some } \delta_1 > 0.$$

Then

$$\sup_{f \in \mathcal{F}} |S_n(f) - \mathbb{E}(S_n(f))| \xrightarrow{L_p} 0,$$

where $S_n(f) := \sum_{j \leq j(n)} w_{nj}(f) \cdot \xi_{nj}$, $f \in \mathcal{F}$, and where the processes $(w_{nj}(f) \cdot \xi_{nj})_{f \in \mathcal{F}}$ are defined as coordinate projections on the product space $(\Omega, \mathcal{A}, \mathbb{P})$ as introduced above.

6.2 ULLN's for partial-sum processes with either fixed or random locations

Let $X = (X, \mathcal{X})$ be an arbitrary measurable space, $\mathcal{C} \subset \mathcal{X}$ a countable VCC, $(\eta_{nj})_{1 \leq j \leq j(n), n \in \mathbb{N}}$ be a triangular array of re's in (X, \mathcal{X}) and $(\xi_{nj})_{1 \leq j \leq j(n), n \in \mathbb{N}}$ a triangular array of rv's with $j(n) \rightarrow \infty$ as $n \rightarrow \infty$, such that for each $n \in \mathbb{N}$ the sequence of pairs $(w_{n1}, \xi_{n1}), \dots, (w_{nj(n)}, \xi_{nj(n)})$ is independent but not necessarily identically distributed; also the components within each pair need not be independent.

Then, by taking $w_{nj} := \delta_{\eta_{nj}}$ ($\delta_{\eta_{nj}}$ = Dirac measure at η_{nj}) we obtain from 6.1.8 immediately the following result for partial-sum processes with random locations as introduced in section 3.2.1:

6.2.1 THEOREM (cf. [Gae94b], Theorem 3.1).

Assume that the following two conditions are fulfilled:

$$(6.2.2) \quad \lim_{n \rightarrow \infty} \sum_{j \leq j(n)} \mathbb{E}(|\xi_{nj}| \cdot I(|\xi_{nj}| > \delta)) = 0 \quad \text{for all } \delta > 0$$

$$(6.2.3) \quad \sup_{n \in \mathbb{N}} \sum_{j \leq j(n)} \mathbb{E}(|\xi_{nj}| \cdot I(|\xi_{nj}| \leq \delta_1)) < \infty \quad \text{for some } \delta_1 > 0.$$

Then, for the partial-sum processes $S_n = (S_n(C))_{C \in \mathcal{C}}$ defined by

$$S_n(C) := \sum_{j \leq j(n)} 1_C(\eta_{nj}) \cdot \xi_{nj}, \quad C \in \mathcal{C},$$

one has

$$(6.2.4) \quad \lim_{n \rightarrow \infty} \mathbb{E} \left(\sup_{C \in \mathcal{C}} |S_n(C) - \mathbb{E}(S_n(C))| \right) = 0.$$

6.2.5 Remark.

Note that (6.2.2) and (6.2.3) together imply that $\sup_{n \in \mathbb{N}} \sum_{j \leq j(n)} \mathbb{E}(|\xi_{nj}|) < \infty$, and thus $\mathbb{E}(S_n(C))$ exists for all $n \in \mathbb{N}$ and $C \in \mathcal{C}$.

In the *identically distributed (id)* - case, that is, when $\xi_{nj} = j(n)^{-1}\xi_j, 1 \leq j \leq j(n), n \in \mathbb{N}$, with $j(n) \rightarrow \infty$ as $n \rightarrow \infty$, for some sequence $(\xi_j)_{j \in \mathbb{N}}$ of identically distributed ξ_j , we have for each $\delta > 0$

$$\sum_{j \leq j(n)} \mathbb{E} \left(|\xi_{nj}| \cdot I(|\xi_{nj}| > \delta) \right) = \mathbb{E} \left(|\xi_1| \cdot I(|\xi_1| > \delta j(n)) \right)$$

and

$$\sup_{n \in \mathbb{N}} \sum_{j \leq j(n)} \mathbb{E} \left(|\xi_{nj}| \cdot I(w_{nj}(F) |\xi_{nj}| \leq \delta) \right) \leq \sup_{n \in \mathbb{N}} \sum_{j \leq j(n)} \mathbb{E}(|\xi_{nj}|) = \mathbb{E}(|\xi_1|),$$

whence in the id-case both conditions (6.2.2) and (6.2.3) are fulfilled under the only assumption $\mathbb{E}(|\xi_1|) < \infty$.

From Theorem 6.2.1 together with Remark 6.2.5 we obtain

6.2.6 Corollary.

Let $S_n(C) := j(n)^{-1} \sum_{j \leq j(n)} 1_C(\eta_{nj}) \cdot \xi_j$, $C \in \mathcal{C}$, $\mathcal{C} \subset \mathcal{X}$ being a countable VCC, $(w_{nj})_{1 \leq j \leq j(n), n \in \mathbb{N}}$ be a triangular array of re's in (X, \mathcal{X}) with $j(n) \rightarrow \infty$ as $n \rightarrow \infty$, and let $(\xi_j)_{j \in \mathbb{N}}$ be a sequence of identically distributed rv's ξ_j with $\mathbb{E}(|\xi_1|) < \infty$ such that for all $n \in \mathbb{N}$ $(w_{n1}, \xi_1), \dots, (w_{nj(n)}, \xi_n)$ is a sequence of independent but not necessarily identically distributed pairs of re's in $(X \times \mathbb{R}, \mathcal{X} \otimes \mathcal{B})$. Then

$$\lim_{n \rightarrow \infty} \mathbb{E} \left(\sup_{C \in \mathcal{C}} |S_n(C) - \mathbb{E}(S_n(C))| \right) = 0.$$

Concerning partial-sum processes with fixed locations in $X = I^d \equiv [0, 1]^d, d \geq 1$, Theorem 6.2.1 together with Remark 6.2.5 implies the following result (cf. section 1.3 and 1.4):

6.2.7 Corollary.

Let $S_n(C) := n^{-d} \sum_{\underline{j} \in J_n} 1_C(\underline{j}/n) \cdot \xi_{\underline{j}}$, $C \in \mathcal{C}$, where $\xi_{\underline{j}}, \underline{j} \in \mathbb{N}^d$, are iid rv's with $\mathbb{E}(|\xi_{\underline{1}}|) < \infty$, and where $\mathcal{C} \subset I^d \cap \mathcal{B}^d$ is a countable VCC; then

$$\lim_{n \rightarrow \infty} \mathbb{E} \left(\sup_{C \in \mathcal{C}} |S_n(C) - n^{-d} |J_n \cap (nC)| \cdot \mathbb{E}(|\xi_{\underline{1}}|) \right) = 0,$$

where $J_n := \{1, \dots, n\}^d$ (and $nC := \{nc : c \in \mathcal{C}\}$).

6.2.8 Remark.

Considering, more generally, function-indexed partial-sum processes $S_n = (S_n(f))_{f \in \mathcal{F}}$, defined by

$$S_n(f) := j(n)^{-1} \sum_{j \leq j(n)} f(\eta_{nj}) \cdot \xi_j, \quad f \in \mathcal{F},$$

with \mathcal{F} being a countable and uniformly bounded VCGC (i.e. with envelope $F \equiv M < \infty$), and where $(\eta_{nj})_{1 \leq j \leq j(n), n \in \mathbb{N}}$ is a triangular array of re's in (X, \mathcal{X}) with $j(n) \rightarrow \infty$ as $n \rightarrow \infty$, and $\xi_j, j \in \mathbb{N}$, are identically distributed rv's with $\mathbb{E}(|\xi_1|) < \infty$ such that for all $n \in \mathbb{N}$ $(\eta_{n1}, \xi_1), \dots, (\eta_{nj(n)}, \xi_{j(n)})$ is a sequence of independent but not necessarily identically distributed pairs of re's in $(X \times \mathbb{R}, \mathcal{X} \otimes \mathcal{B})$, then in the same way as in the set-indexed case above, Theorem 6.2.1 together with Remark 6.2.5 yields

$$\lim_{n \rightarrow \infty} \mathbb{E} \left(\sup_{f \in \mathcal{F}} |S_n(f) - \mathbb{E}(S_n(f))| \right) = 0.$$

6.3 ULLN's for empirical processes

Given an arbitrary measurable space $X = (X, \mathcal{X})$, let us consider at first the set-indexed case, i.e. with a countable VCC $\mathcal{C} \subset \mathcal{X}$ as parameter space for the empirical measures $\nu_n = (\nu_n(C))_{C \in \mathcal{C}}$ defined by

$$\nu_n(C) := j(n)^{-1} \sum_{j \leq j(n)} 1_C(\eta_{nj}), \quad C \in \mathcal{C},$$

where $(\eta_{nj})_{1 \leq j \leq j(n), n \in \mathbb{N}}$ is a triangular array of rowwise independent but not necessarily identically distributed re's in (X, \mathcal{X}) with $j(n) \rightarrow \infty$ as $n \rightarrow \infty$. Then it follows from Corollary 6.2.6 (with $\xi_j \equiv 1$) that

$$(6.3.1) \quad \lim_{n \rightarrow \infty} \mathbb{E} \left(\sup_{C \in \mathcal{C}} |\nu_n(C) - \bar{\nu}_n(C)| \right) = 0,$$

where $\bar{\nu}_n(C) := j(n)^{-1} \sum_{j \leq j(n)} \mathbb{P}(\eta_{nj} \in C)$, $C \in \mathcal{C}$.

Especially, if for each $n \in \mathbb{N}$ $\eta_{nj} = \eta_j$, $1 \leq j \leq j(n)$, with $\eta_j, j \in \mathbb{N}$, being iid re's in (X, \mathcal{X}) with law ν on \mathcal{X} , then for

$$\nu_n(C) := j(n)^{-1} \sum_{j \leq j(n)} 1_C(\eta_j), \quad C \in \mathcal{C},$$

it follows together with (2.1.5) that (cf. Theorem 2.1.6)

$$(6.3.2) \quad \|\nu_n - \nu\|_{\mathcal{C}} := \sup_{C \in \mathcal{C}} |\nu_n(C) - \nu(C)| \rightarrow 0 \quad \mathbb{P} - a.s.$$

As to the function-indexed case we get from Corollary 6.1.8 (with $p = 1, w_{nj} := \delta_{\eta_j}$ and $\xi_{nj} := j(n)^{-1}, 1 \leq j \leq j(n), n \in \mathbb{N}$) the following more general result mentioned already in connection with (4.3.9):

6.3.3 THEOREM.

Let $X = (X, \mathcal{X})$ be an arbitrary measurable space, $\eta_j, j \in \mathbb{N}$, be iid re's in (X, \mathcal{X}) with law ν on \mathcal{X} (defined as coordinate projections on the p -space $(\Omega, \mathcal{A}, \mathbb{P}) := (X^{\mathbb{N}}, \mathcal{X}^{\mathbb{N}}, \nu^{\mathbb{N}})$), and let \mathcal{F} be a countable VCGC of \mathcal{X} -measurable functions $f : X \rightarrow \mathbb{R}$ with \mathcal{X} -measurable envelope $F : X \rightarrow \mathbb{R}$ such that $\nu(F) := \int_X F d\nu < \infty$. Then, for $\nu_n(f) := j(n)^{-1} \sum_{j \leq j(n)} f(\eta_j)$, $f \in \mathcal{F}$, one has (with $j(n) \rightarrow \infty$ as $n \rightarrow \infty$)

$$(6.3.4) \quad \lim_{n \rightarrow \infty} \mathbb{E} \left(\sup_{f \in \mathcal{F}} |\nu_n(f) - \nu(f)| \right) = 0.$$

Moreover, by the same reversed martingale argument which led to (2.1.5) one obtains also

$$(6.3.5) \quad \sup_{f \in \mathcal{F}} |\nu_n(f) - \nu(f)| \rightarrow 0 \quad \mathbb{P} - a.s.$$

PROOF. According to 6.1.8 we have to verify (6.1.3) (with $p = 1$) and (6.1.4), where now $w_{nj}(F) = \delta_{\eta_j}(F) = F(\eta_j)$ and $\xi_{nj} = j(n)^{-1}$, i.e.

$$(+) \quad \lim_{n \rightarrow \infty} \sum_{j \leq j(n)} \mathbb{E} \left(F(\eta_j) \cdot j(n)^{-1} \cdot I(F(\eta_j) j(n)^{-1} > \delta) \right) = 0 \quad \forall \delta > 0, \text{ and}$$

$$(++) \quad \sup_{n \in \mathbb{N}} \sum_{j \leq j(n)} \mathbb{E} \left(F(\eta_j) \cdot j(n)^{-1} \cdot I(F(\eta_j) j(n)^{-1} \leq \delta_1) \right) < \infty \quad \text{for some } \delta_1 > 0.$$

As to (+), $\sum_{j \leq j(n)} \mathbb{E} \left(F(\eta_j) \cdot j(n)^{-1} \cdot I(F(\eta_j) j(n)^{-1} > \delta) \right) = \mathbb{E} \left(F(\eta_1) \cdot I(F(\eta_1) > \delta j(n)) \right) \rightarrow 0$ as $n \rightarrow \infty$, since $\mathbb{E}(F(\eta_1)) = \nu(F) < \infty$ by assumption.

As to (++), $\sup_{n \in \mathbb{N}} \sum_{j \leq j(n)} \mathbb{E} \left(F(\eta_j) \cdot j(n)^{-1} \cdot I(F(\eta_j) j(n)^{-1} \leq \delta_1) \right) = \sup_{n \in \mathbb{N}} \mathbb{E} \left(F(\eta_1) \cdot I(F(\eta_1) \leq \delta_1 j(n)) \right) \leq \mathbb{E}(F(\eta_1)) < \infty$. \square

6.4 ULLN's for smoothed empirical processes

Throughout this section X is supposed to be an arbitrary *linear metric space* endowed with its Borel σ -field \mathcal{X} .

Let $\eta_j, j \in \mathbb{N}$, be iid re's in (X, \mathcal{X}) with law ν on \mathcal{X} (defined as coordinate projections on the p-space $(\Omega, \mathcal{A}, \mathbb{P}) := (X^{\mathbb{N}}, \mathcal{X}^{\mathbb{N}}, \nu^{\mathbb{N}})$).

Let $\nu_n := n^{-1} \sum_{j \leq n} \delta_{\eta_j}$ be the empirical measure based on $\eta_1, \dots, \eta_n, n \in \mathbb{N}$, viewed as nonparametric estimator (of sample size n) for ν .

If the underlying ν is "smooth" it is natural to use a "smoothed" version $\tilde{\nu}_n$ of ν_n as an estimator for ν , rather than the empirical measure itself.

Following Yukich [Yu89] we consider *smoothing through convolution* as follows:

Given a sequence $(\mu_n)_{n \in \mathbb{N}}$, of p-measures μ_n on \mathcal{X} let

$$\tilde{\nu}_n := \nu_n \star \mu_n$$

be the so-called *smoothed empirical measure* based on η_1, \dots, η_n , i.e.

$$(6.4.1) \quad \tilde{\nu}_n(B) := \int_X \int_X 1_B(x+y) \nu_n(dx) \mu_n(dy), \quad B \in \mathcal{X}.$$

Note that $\tilde{\nu}_n \equiv \nu_n$ if $\mu_n \equiv \delta_0$ (Dirac measure at 0).

Taking $X = \mathbb{R}$, the following picture shows that by convolution we can turn the discrete empirical measure ν_n into a continuous one. This is not surprising since $\nu_n \star \mu_n$ has a Lebesgue density if μ_n has one.

For illustration we take $n = 4$, μ_n the uniform distribution on $[-1, 1]$ and x_1, \dots, x_n a sample from the rv's η_1, \dots, η_n . The picture shows the distribution functions which are also denoted by ν_n, μ_n and $\tilde{\nu}_n$, respectively.

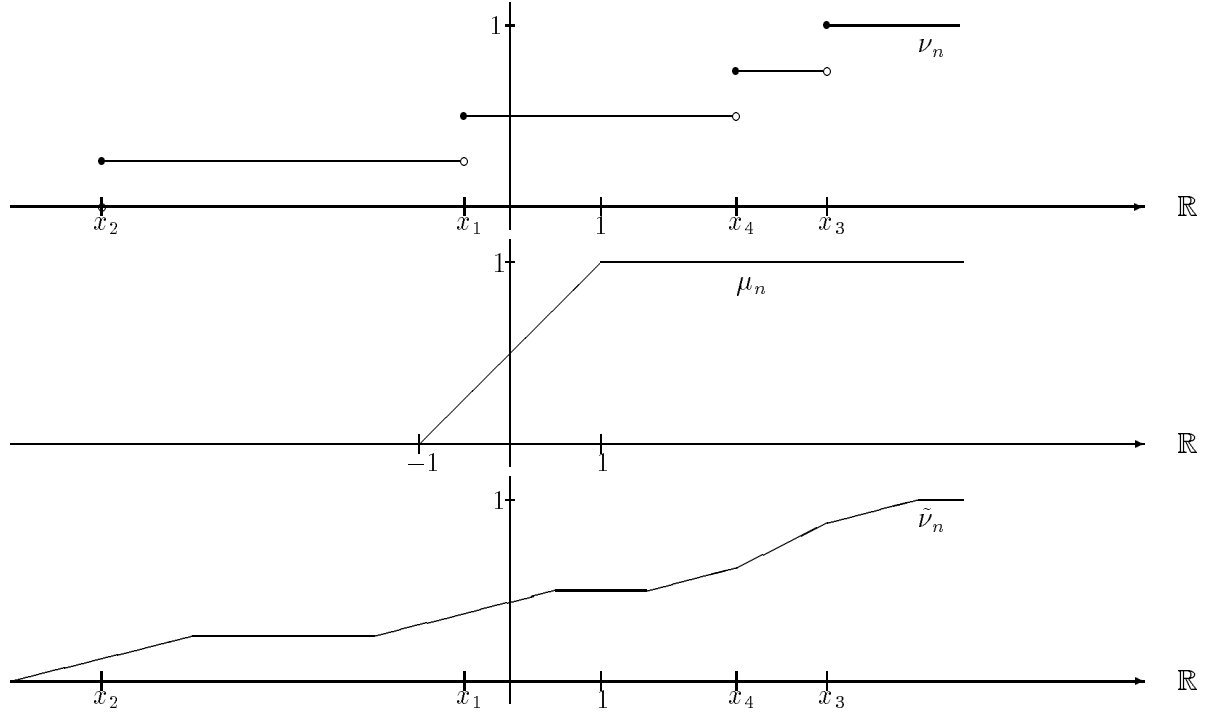

(6.4.1) also includes *kernel smoothing in density estimation*. For this, let us take $X = \mathbb{R}$ for simplicity, and let for each $u \in \mathbb{R}$ $\mu_n((-\infty, u]) := H(\frac{u}{h_n})$, $h_n > 0$, where

$$H(s) := \int_{-\infty}^s K(v)dv, \quad K \geq 0, \quad \int_{\mathbb{R}} K(v) dv = 1;$$

(note that in this case $\mu_n \rightarrow \delta_0$ weakly if $h_n \rightarrow 0$ as $n \rightarrow \infty$).

Then, for each $u \in \mathbb{R}$

$$\begin{aligned} \tilde{\nu}_n((-\infty, u]) &\stackrel{(6.4.1)}{=} \int_{\mathbb{R}} \left[n^{-1} \sum_{j \leq n} 1_{(-\infty, u]}(\eta_j + y) \right] \mu_n(dy) \\ &= n^{-1} \sum_{j \leq n} \mu_n((-\infty, u - \eta_j]) = n^{-1} \sum_{j \leq n} H\left(\frac{u - \eta_j}{h_n}\right) \\ &= n^{-1} \sum_{j \leq n} h_n^{-1} \int_{-\infty}^u K\left(\frac{v - \eta_j}{h_n}\right) dv, \quad \text{i.e.} \end{aligned}$$

$$\tilde{\nu}_n((-\infty, u]) = \int_{-\infty}^u \hat{g}_n(t) dt \quad \forall u \in \mathbb{R} \quad \text{with}$$

$\hat{g}_n(t) := (nh_n)^{-1} \sum_{j \leq n} K(\frac{t - \eta_j}{h_n})$ being the kernel density estimator for the underlying density $g(t)$ of the $\mathcal{L}\{\eta_j\}$'s.

Returning to an arbitrary linear metric space X , let \mathcal{F} be a class of \mathcal{X} -measurable functions $f : X \rightarrow \mathbb{R}$ with \mathcal{X} -measurable envelope $F : X \rightarrow \mathbb{R}$. For each $f \in \mathcal{F}$, put

$$(6.4.2) \quad \tilde{\nu}_n(f) := \int_X f d\tilde{\nu}_n,$$

tacitly assuming that the integrals of functions $f \in \mathcal{F}$ do exist.

For $\tilde{\nu}_n(f)$ this is the case if $\int_X |f(x+y)| \mu_n(dy) < \infty \quad \forall x \in X$.

Note that (cf. (6.4.1))

$$(6.4.3) \quad \tilde{\nu}_n(f) = \int_X \int_X f(x+y) \nu_n(dx) \mu_n(dy) = n^{-1} \sum_{j \leq n} \int_X f(\eta_j + y) \mu_n(dy), \text{ and}$$

$$(6.4.4) \quad \mathbb{E}(\tilde{\nu}_n(f)) = \nu \star \mu_n(f) \quad \forall f \in \mathcal{F} \text{ and } n \in \mathbb{N}.$$

(In fact, as to (6.4.4), $\mathbb{E}(\tilde{\nu}_n(f)) = \int_X \mathbb{E}\left(\int_X f(x+y) \nu_n(dx)\right) \mu_n(dy) = \int_X \mathbb{E}\left(n^{-1} \sum_{j \leq n} f(\eta_j + y)\right) \mu_n(dy) = \int_X \int_X f(x+y) \nu(dx) \mu_n(dy) = \nu \star \mu_n(f)$.)

It will be also tacitly assumed that suprema over $f \in \mathcal{F}$, like $\sup_{f \in \mathcal{F}} |\tilde{\nu}_n(f) - \nu(f)|$, are measurable (being the case by assuming, as in the former sections, that \mathcal{F} is countable, for simplicity).

Now, our aim is to present ULLN's, i.e. sufficient conditions on \mathcal{F} and the smoothing measures $\mu_n, n \in \mathbb{N}$, under which (for $1 \leq p < \infty$)

$$(6.4.5) \quad \sup_{f \in \mathcal{F}} |\tilde{\nu}_n(f) - \nu(f)| \xrightarrow{L_p} 0.$$

Concerning $(\tilde{\nu}_n)_{n \in \mathbb{N}}$ as an estimator sequence for an unknown ν , from (6.4.5) one can of course only deduce weak consistency, but, as Pfanzagl [Pf94], p. 188, remarks *strong consistency, i.e. almost sure convergence of an estimator sequence, adds nothing to weak consistency, i.e. convergence in probability, which could be of use on the way to the asymptotic distributions of estimator sequences*. Thus, it is reasonable to seek for sufficient conditions under which (6.4.5) holds true.

Concerning once more the above example of kernel smoothing, (6.4.5) yields $\sup_{u \in \mathbb{R}} |\hat{G}_n(u) - G(u)| \xrightarrow{L_p} 0$, where $\hat{G}_n(u) := \tilde{\nu}_n((-\infty, u])$, $u \in \mathbb{R}$, and where G is the df of the η_j 's.

Fernholz [Fe91] remarks on the estimator \hat{G}_n :

Estimators \hat{G}_n derived by integrating density estimators have required less attention. Although estimating a density g by using \hat{g}_n or its distribution function G by using \hat{G}_n are equivalent problems, the error of the corresponding estimator is usually measured in different ways. For density estimation the “ L_1 view” (see Devroye and Györfi [Dev85]) based on the L_1 error $\|\hat{g}_n - g\|_1$ has been gaining popularity over the more traditional L_2 approach using $\|\hat{g}_n - g\|_2$.

In kernel distribution function estimation the discrepancy error between \hat{G}_n and G should be measured in terms of some distance in the space of distribution functions. Metrics such as the supremum norm, the Prohorov distance, or the Levy distance, provide a useful framework to study the properties of \hat{G}_n .

Indeed, from Winter [Win73] and Yamato [Ya73] we have a.s. uniform convergence of \hat{G}_n to G , see also Mack [Ma84] and Prakasa Rao [Pra81].

A more general setting for studying estimators (as already considered in [Win73] and [Ya73]) for a distribution function G is obtained if \hat{G}_n is defined by

$$\hat{G}_n(u) := n^{-1} \sum_{j \leq n} \mu_n((-\infty, u - \eta_j)) \quad , \quad u \in \mathbb{R},$$

with p-measures μ_n on \mathcal{B} (not necessarily having a density). \hat{G}_n is then called *smoothed* (or *perturbed empirical distribution function*) with the above mentioned kernel smoothing as a special case. Note that in general, i.e. for arbitrary linear metric spaces X , smoothing by convolution is its natural extension, since (cf. (6.4.1))

$$(6.4.6) \quad \tilde{\nu}_n(B) = n^{-1} \sum_{j \leq n} \int_X 1_B(\eta_j + y) \mu_n(dy) = n^{-1} \sum_{j \leq n} \mu_n(B - \eta_j), \quad B \in \mathcal{X}.$$

Now, we are going to mention at first the traditional approach towards ULLN's for smoothed empirical measures. We will formulate it for an arbitrary metric space X and for classes \mathcal{F} of \mathcal{X} -measurable functions $f : X \rightarrow \mathbb{R}$ being uniformly bounded, i.e. with $\sup_{f \in \mathcal{F}} \sup_{x \in X} |f(x)| \leq M < \infty$. We do not lose anything if we assume here and in the following that $M = 1$ (which means that the constant function M serves as an envelope of \mathcal{F}). Let $\tilde{\mathcal{F}}$ be the class of all *translates* of elements of \mathcal{F} , i.e.

$$\tilde{\mathcal{F}} := \{f_x : x \in X, f \in \mathcal{F}\},$$

where $f_x : X \rightarrow \mathbb{R}$ is defined by $f_x(y) := f(x + y)$, $y \in X$. Now consider the decomposition

$$(6.4.7) \quad \tilde{\nu}_n - \nu = \tilde{\nu}_n - \nu \star \mu_n + \nu \star \mu_n - \nu,$$

where (cf. (6.4.4)) $\mathbb{E}(\tilde{\nu}_n(f)) = \nu \star \mu_n(f) \quad \forall f \in \mathcal{F}$, thus $\nu \star \mu_n(f) - \nu(f)$ being the *non-stochastic bias* of $\tilde{\nu}_n(f)$, $f \in \mathcal{F}$.

The decomposition (6.4.7) together with the assumption $\mathcal{F} = \tilde{\mathcal{F}}$ (saying that \mathcal{F} is *closed under translation*) is essential for the following lemma:

6.4.8 Lemma.

Let X be a linear metric space and suppose that $\mathcal{F} = \tilde{\mathcal{F}}$. Assume further that

$$\sup_{f \in \mathcal{F}} |\nu_n(f) - \nu(f)| \xrightarrow{L_p} 0 \quad \text{and} \quad \sup_{f \in \mathcal{F}} |\nu \star \mu_n(f) - \nu(f)| \rightarrow 0.$$

Then

$$\sup_{f \in \mathcal{F}} |\tilde{\nu}_n(f) - \nu(f)| \xrightarrow{L_p} 0.$$

PROOF. According to (6.4.7) it suffices to show that

$$\sup_{f \in \mathcal{F}} |\tilde{\nu}_n(f) - \nu \star \mu_n(f)| \leq \sup_{f \in \mathcal{F}} |\nu_n(f) - \nu(f)|.$$

For this, let $g \in \mathcal{F}$ be arbitrary; then

$$\begin{aligned} |\tilde{\nu}_n(g) - \nu \star \mu_n(g)| &= |\nu_n \star \mu_n(g) - \nu \star \mu_n(g)| \\ &= \left| \int_X \int_X g(x+y) \nu_n(dx) \mu_n(dy) - \int_X \int_X g(x+y) \nu(dx) \mu_n(dy) \right| \\ &= \left| \int_X \int_X g_y(x) \nu_n(x) \mu_n(dy) - \int_X \int_X g_y(x) \nu(dx) \mu_n(dy) \right| \\ &= \left| \int_X (\nu_n(g_y) - \nu(g_y)) \mu_n(dy) \right| \\ &\leq \int_X \sup_{f \in \mathcal{F}} |\nu_n(f) - \nu(f)| \mu_n(dy) \\ &= \sup_{f \in \mathcal{F}} |\nu_n(f) - \nu(f)|. \end{aligned}$$

□

Concerning the bias-term $\nu \star \mu_n - \nu = \nu \star \mu_n - \nu \star \delta_0$ ($\delta_0 =$ Dirac measure at 0) one shows in the same way that in the case $\mathcal{F} = \tilde{\mathcal{F}}$

$$(6.4.9) \quad \sup_{f \in \mathcal{F}} |\nu \star \mu_n(f) - \nu \star \delta_0(f)| \leq \sup_{f \in \mathcal{F}} |\mu_n(f) - \delta_0(f)|,$$

where, e.g. for separable X and uniformly bounded equicontinuous classes \mathcal{F} $\sup_{f \in \mathcal{F}} |\mu_n(f) - \delta_0(f)| \rightarrow 0$ if $\mu_n \rightarrow \delta_0$ weakly (in the sense of weak convergence of Borel p-measures in metric spaces); cf. Theorem 1.12.1 in [Va96].

The conditions of Lemma 6.4.8 are fulfilled e.g. if $X = \mathbb{R}$, $\mathcal{F} = \{1_{(-\infty, t]}, t \in \mathbb{R}\}$, $\mu_n \rightarrow \delta_0$ weakly and ν being a continuous p-measure on \mathcal{B} in \mathbb{R} . The result in this special case goes back to Winter [Win73] and Yamato [Ya73].

The disadvantage of Lemma 6.4.8 (and (6.4.9)) is that it only holds under the rather restrictive assumption $\mathcal{F} = \tilde{\mathcal{F}}$, a condition which cannot be dispensed with in general; see Example 2.2. in [Gae99].

Note also that assuming the existence of a *real-valued* envelope F of \mathcal{F} , the condition $\mathcal{F} = \tilde{\mathcal{F}}$ implies that \mathcal{F} is uniformly bounded (i.e. $\sup_{x \in X} \sup_{f \in \mathcal{F}} |f(x)| < \infty$).

For $X = \mathbb{R}^d$, $d \leq 1$, Lemma 6.4.8 can be found in [Yu89] with a.s. convergence replacing convergence in the L_p -norm. Also from Yukich [Yu89] we know the following result in the case $X = \mathbb{R}^d$, $d \geq 1$:

6.4.10 THEOREM (Yukich).

Let $X = \mathbb{R}^d$, $d \geq 1$, and assume $\mu_n \rightarrow \delta_0$ weakly and that

\mathcal{F} is uniformly bounded

and

$$(6.4.11) \quad N^{[\]}(\tau, \mathcal{F}, \nu) < \infty \quad \text{for all } \tau > 0$$

where $N^{[\]}(\tau, \mathcal{F}, \nu) := \min\{m \in \mathbb{N} : \exists f_1, \dots, f_m : X \rightarrow \mathbb{R}, f_i \text{ continuous, } \nu\text{-integrable such that for all } f \in \mathcal{F} \text{ there exist } f_i, f_j \text{ with } f_i \leq f \leq f_j \text{ and } \nu(f_j - f_i) < \tau\}$.

Then

$$\sup_{f \in \mathcal{F}} |\tilde{\nu}_n(f) - \nu(f)| \xrightarrow{L_p} 0 .$$

Here one gets rid of the assumption $\mathcal{F} = \tilde{\mathcal{F}}$, but the condition (6.4.11) on the so-called covering number *with bracketing* is rather strong: Taking \mathcal{F} uniformly bounded and $\mu_n \equiv \delta_0$, Theorem 6.4.10 leaves (6.4.11) as a sufficient condition for a ULLN in the case of non-smoothed empirical measures, a sufficient condition which is far away from being necessary (Talagrand [Ta96]), especially in view of the continuity assumption on the f_i 's which normally is not involved in the definition of covering numbers with bracketing. As we shall see below, Theorem 6.4.10 will follow from our ULLN 6.4.17 (cf. Lemma 6.4.22).

Next, also not imposing the assumption $\mathcal{F} = \tilde{\mathcal{F}}$, there is a completely different way to obtain ULLN's for smoothed empirical measures via the *Random Measure Process Approach*, being based on our Theorem 6.1.2:

For this, note that $\tilde{\nu}_n(f)$ can be represented as (cf (6.4.3))

$$\tilde{\nu}_n(f) = \sum_{j \leq j(n)} w_{nj}(f) \cdot \xi_{nj}$$

by taking $j(n) := n$, $w_{nj}(f) := \int_X f(\eta_j + y) \mu_n(dy)$, and $\xi_{nj} := n^{-1}$. Thus, in view of the decomposition (6.4.7) together with (6.4.4) Theorem 6.1.2 yields the following ULLN. (Note that the η_j 's on which the w_{nj} 's are based are i.i.d.)

6.4.12 THEOREM.

Let X be a linear metric space and assume that (6.4.13) – (6.4.16) hold, where (for $1 \leq p < \infty$)

$$(6.4.13) \quad \lim_{n \rightarrow \infty} \mathbb{E} \left(w_{n1}(F)^p \cdot I(n^{-1}w_{n1}(F) > \delta) \right) = 0 \quad \text{for all } \delta > 0$$

$$(6.4.14) \quad \sup_{n \in \mathbb{N}} \mathbb{E} \left(w_{n1}(F) \cdot I(n^{-1}w_{n1}(F) \leq \delta_1) \right) < \infty \quad \text{for some } \delta_1 > 0$$

$$(6.4.15) \quad \text{For all } \tau > 0 \text{ there exists } \delta \equiv \delta(\tau) > 0 \text{ such that} \\ (N(\tau \cdot \mu_{n\delta}(F), \mathcal{F}, \bar{d}_{\mu_{n\delta}}^{(1)}))_{n \in \mathbb{N}} \text{ is stochastically bounded.}$$

$$(6.4.16) \quad \sup_{f \in \mathcal{F}} |\nu \star \mu_n(f) - \nu(f)| \longrightarrow 0 .$$

Then

$$\sup_{f \in \mathcal{F}} |\tilde{\nu}_n(f) - \nu(f)| \xrightarrow{L_p} 0 .$$

Now again (cf. the Note before 6.1.7) the condition (6.4.15) can be replaced by

$$(6.4.15)' \quad \text{For all } \tau > 0 \text{ there exists } \delta \equiv \delta(\tau) > 0 \text{ such that} \\ (N(\tau, \mathcal{F}, \bar{d}_{\mu_{n\delta}}^{(1)}))_{n \in \mathbb{N}} \text{ is stochastically bounded.}$$

and, since

$$\bar{d}_{\mu_{n\delta}}^{(1)}(f, g) \leq \bar{d}_{\tilde{\nu}_n}^{(1)}(f, g) \quad \forall f, g \in \mathcal{F}$$

even by

$$(6.4.15)'' \quad (N(\tau, \mathcal{F}, \bar{d}_{\tilde{\nu}_n}^{(1)}))_{n \in \mathbb{N}} \text{ is stochastically bounded for all } \tau > 0$$

where $\bar{d}_{\tilde{\nu}_n}^{(1)}$ is defined by

$$\bar{d}_{\tilde{\nu}_n}^{(1)}(f, g) := \int_X \left| \int_X (f(x+y) - g(x+y)) \mu_n(dy) \right| \nu_n(dx)$$

for $f, g \in \mathcal{F}$.

Next, take a closer look at the case when \mathcal{F} is uniformly bounded. Then $\{n^{-1}w_{nj}(F) > \delta\} = \emptyset$ and $\{n^{-1}w_{nj}(F) \leq \delta\} = \Omega$ for each $\delta > 0$ and large enough n . Thus (6.4.13) and (6.4.14) are fulfilled in this case. Furthermore, for every $\delta > 0$ we have $\bar{d}_{\mu_{n\delta}}^{(1)} = \bar{d}_{\tilde{\nu}_n}^{(1)}$ for large enough n . So Theorem 6.4.12 yields

6.4.17 THEOREM.

Let X be a linear metric space and suppose that \mathcal{F} is uniformly bounded. Assume that (6.4.16) and (6.4.18) hold, where

$$(6.4.18) \quad \text{For all } \tau > 0 \quad (N(\tau, \mathcal{F}, \bar{d}_{\tilde{\nu}_n}^{(1)}))_{n \in \mathbb{N}} \text{ is stochastically bounded.}$$

Then (for each $1 \leq p < \infty$)

$$\sup_{f \in \mathcal{F}} |\tilde{\nu}_n(f) - \nu(f)| \xrightarrow{L_p} 0 .$$

Since, for uniformly bounded \mathcal{F} (with $F \equiv 1$ w.l.o.g.),

$$N(\tau, \mathcal{F}, \bar{d}_{\tilde{\nu}_n}^{(1)}) = N(\tau \cdot \mu_{n\delta}(F), \mathcal{F}, \bar{d}_{\mu_{n\delta}}^{(1)})$$

for large enough n , we get from Theorem 6.4.17 together with 6.1.7 the following result in case of uniformly bounded VCGC's \mathcal{F} :

6.4.19 THEOREM.

Let X be a linear metric space and let \mathcal{F} be a uniformly bounded VCGC. Assume uniform convergence to zero of the bias-term, i.e. $\sup_{f \in \mathcal{F}} |\nu \star \mu_n(f) - \nu(f)| \rightarrow 0$.

Then (for each $1 \leq p < \infty$)

$$\sup_{f \in \mathcal{F}} |\tilde{\nu}_n(f) - \nu(f)| \xrightarrow{L_p} 0 .$$

In the context of smoothed empirical measures or processes, respectively, one usually assumes $\mu_n \rightarrow \delta_0$ weakly. Note however that in our theorems we did not assume weak convergence of $(\mu_n)_{n \in \mathbb{N}}$ in advance. This does not follow from (6.4.16) nor does $\mu_n \rightarrow \delta_0$ weakly imply (6.4.16) as can be seen by the following example:

6.4.20 Example.

Let $X := \mathbb{R}$, $\mathcal{F} := \{1_{(-\infty, t]} : t \in \mathbb{Q}\}$, $\nu = \delta_0$ and $\mu_n := \delta_{\frac{1}{n}}$, $n \in \mathbb{N}$. Then $\mu_n \rightarrow \delta_0$ weakly, but (6.4.16) does not hold; in fact, $\sup_{f \in \mathcal{F}} |\nu \star \mu_n(f) - \nu(f)| \equiv 1$.

On the other hand, since (6.4.13) – (6.4.15) are fulfilled, this example also shows that (6.4.16) cannot be dispensed with, in general, for our theorems 6.4.12, 6.4.17 and 6.4.19 to hold true, since in the present case $\mathbb{E}(\sup_{f \in \mathcal{F}} |\tilde{\nu}_n(f) - \nu(f)|) \equiv 1$.

However, if \mathcal{F} is “smooth” we can deduce (6.4.16) from $\mu_n \rightarrow \delta_0$ weakly (without assuming $\mathcal{F} = \tilde{\mathcal{F}}$; cf. (6.4.9) and the remarks made there).

Assuming X to be separable, we obtain the following result:

6.4.21 THEOREM.

Let X be a separable linear metric space and let \mathcal{F} be a uniformly bounded equicontinuous VCGC. Suppose that $\mu_n \rightarrow \delta_0$ weakly. Then (for each $1 \leq p < \infty$)

$$\sup_{f \in \mathcal{F}} |\tilde{\nu}_n(f) - \nu(f)| \xrightarrow{L_p} 0 .$$

PROOF. According to Theorem 6.4.19 it suffices to verify (6.4.16), i.e. $\sup_{f \in \mathcal{F}} |\nu \star \mu_n(f) - \nu(f)| \rightarrow 0$:

For each bounded and continuous $f : X \rightarrow \mathbb{R}$ we have by dominated convergence that

$$\begin{aligned} \nu \star \mu_n(f) &= \int_X \int_X f(x+y) \mu_n(dy) \nu(dx) \\ &= \int_X \int_X f_x(y) \mu_n(dy) \nu(dx) \rightarrow \int_X f_x(0) \nu(dx), \end{aligned}$$

since $\mu_n \rightarrow \delta_0$ weakly and $f_x : X \rightarrow \mathbb{R}$ is also bounded and continuous for all $x \in X$, where

$$\int_X f_x(0) \nu(dx) = \nu(f),$$

whence $\nu \star \mu_n \rightarrow \nu$ weakly.

Applying now Theorem 1.12.1 in [Va96] yields (6.4.16). □

6.4.22 Lemma.

Let X be a separable linear metric space and let \mathcal{F} be uniformly bounded satisfying the condition (6.4.11) in Yukich's theorem, i.e. $N^{[]}(\tau, \mathcal{F}, \nu) < \infty$ for all $\tau > 0$. Suppose that $\mu_n \rightarrow \delta_0$ weakly. Then (6.4.18) and (6.4.16) hold true, whence Yukich's theorem comes up as a special case of Theorem 6.4.17.

PROOF. Given any $\tau > 0$ let f_1, \dots, f_m be continuous, ν -integrable and bounded (note that \mathcal{F} is assumed to be uniformly bounded) such that for all $f \in \mathcal{F}$ there exist f_i, f_j with $f_i \leq f \leq f_j$ and $\nu(f_j - f_i) < \tau$ (note that $N^{[]}(\tau, \mathcal{F}, \nu) < \infty$).

Now, for all f_i, f_j with

$$[f_i, f_j] := \{f \in \mathcal{F} : f_i \leq f \leq f_j\} \neq \emptyset$$

choose $g_{ij} \in [f_i, f_j]$. Then, given $f \in \mathcal{F}$ and f_i, f_j with $f \in [f_i, f_j]$ and $\nu(f_j - f_i) < \tau$, we have

$$\tilde{\nu}_n(|f - g_{ij}|) \leq \tilde{\nu}_n(f_j - f_i) = \nu_n \star \mu_n(f_j - f_i) \rightarrow \nu \star \delta_0(f_j - f_i) \text{ a.s.},$$

since $\mu_n \rightarrow \delta_0$ weakly and (cf. e.g. [Gae79], Section 1.5) $\nu_n \rightarrow \nu$ weakly a.s.; note that $f_j - f_i$ is bounded and continuous.

Since $\nu \star \delta_0(f_j - f_i) = \nu(f_j - f_i) < \tau$, it follows that

$$\limsup_{n \rightarrow \infty} N(\tau, \mathcal{F}, d_{\tilde{\nu}_n}^{(1)}) \leq m^2 \text{ a.s.},$$

whence $\left(N(\tau, \mathcal{F}, d_{\tilde{\nu}_n}^{(1)})\right)_{n \in \mathbb{N}}$ is stochastically bounded and therefore also $\left(N(\tau, \mathcal{F}, \bar{d}_{\tilde{\nu}_n}^{(1)})\right)_{n \in \mathbb{N}}$, since

$$\bar{d}_{\tilde{\nu}_n}^{(1)}(f, g) \leq d_{\tilde{\nu}_n}^{(1)}(f, g) := \tilde{\nu}_n(|f - g|) \text{ for } f, g \in \mathcal{F}.$$

So we conclude that (6.4.18) holds.

Next, from $f \in [f_i, f_j]$ and $\nu(f_j - f_i) < \tau$ we can also conclude that

$$\begin{aligned} |\nu \star \mu_n(f) - \nu(f)| &\leq \max\{|\nu \star \mu_n(f_j) - \nu(f_j)| + |\nu(f_j) - \nu(f)|, \\ &\quad |\nu \star \mu_n(f_i) - \nu(f_i)| + |\nu(f_i) - \nu(f)|\}, \end{aligned}$$

thus

$$\sup_{f \in \mathcal{F}} |\nu \star \mu_n(f) - \nu(f)| \leq \max\{|\nu \star \mu_n(f_j) - \nu(f_j)| : 1 \leq j \leq m\} + \tau.$$

But $\nu \star \mu_n(f_j) - \nu(f_j) \rightarrow 0$ for all $j = 1, \dots, m$, since $\nu \star \mu_n \rightarrow \nu$ weakly and the f_j 's are bounded and continuous. So we get

$$\limsup_{n \rightarrow \infty} \sup_{f \in \mathcal{F}} |\nu \star \mu_n(f) - \nu(f)| \leq \tau.$$

Since $\tau > 0$ was arbitrary, this gives (6.4.16). □

Finally, in the non-smoothed case (i.e. with $\mu_n \equiv \delta_0$) one has the following deep result on empirical measures ν_n which we deduce from Talagrand [Ta96]; here X is not required to be a linear metric space.

6.4.23 THEOREM (Talagrand).

Let (X, \mathcal{X}, ν) be a complete p -space and \mathcal{F} be a uniformly bounded class of \mathcal{X} -measurable functions $f : X \rightarrow \mathbb{R}$. Then the condition

$$(6.4.24) \quad (N(\tau, \mathcal{F}, d_{\nu_n}^{(1)}))_{n \in \mathbb{N}} \text{ is stochastically bounded for all } \tau > 0$$

(with $d_{\nu_n}^{(1)}(f, g) := \nu_n(|f - g|)$, $f, g \in \mathcal{F}$) is necessary and sufficient for

$$\sup_{f \in \mathcal{F}} |\nu_n(f) - \nu(f)| \xrightarrow{L_1} 0.$$

In view of this result it is tempting to see what comes up in the smoothed case. The following result will be contained in [Gae99]:

6.4.25 THEOREM.

Let X be a linear metric space endowed with its Borel σ -field \mathcal{X} such that (X, \mathcal{X}, ν) is complete, and let \mathcal{F} be a uniformly bounded class of \mathcal{X} -measurable functions $f : X \rightarrow \mathbb{R}$ which is closed under translations, i.e. $\tilde{\mathcal{F}} = \mathcal{F}$. Suppose that $\sup_{f \in \mathcal{F}} |\mu_n(f) - f(0)| \rightarrow 0$. Then the following statements are equivalent:

- a) $(N(\tau, \mathcal{F}, d_{\nu_n}^{(1)}))_{n \in \mathbb{N}}$ is stochastically bounded for all $\tau > 0$
- b) $(N(\tau, \mathcal{F}, \tilde{d}_{\tilde{\nu}_n}^{(1)}))_{n \in \mathbb{N}}$ is stochastically bounded for all $\tau > 0$
- c) $\sup_{f \in \mathcal{F}} |\tilde{\nu}_n(f) - \nu(f)| \xrightarrow{L_1} 0$
- d) $\sup_{f \in \mathcal{F}} |\nu_n(f) - \nu(f)| \xrightarrow{L_1} 0$.

7 Functional Central Limit Theorems (FCLT)

7.1 A FCLT for RMP's

Our starting point in this section is the same as in 6.1 with the aim to present a Functional Central Limit Theorem (FCLT) for Random Measure Processes (RMP's) $S_n = (S_n(f))_{f \in \mathcal{F}}$, where

$$S_n(f) := \sum_{j \leq j(n)} w_{nj}(f) \cdot \xi_{nj}, \quad f \in \mathcal{F}, \text{ with } j(n) \rightarrow \infty \text{ as } n \rightarrow \infty,$$

assuming again that the processes $(w_{nj}(f) \cdot \xi_{nj})_{f \in \mathcal{F}}$ are given via coordinate projections on the product p-space $(\Omega, \mathcal{A}, \mathbb{P})$ as defined in 6.1.

We tacitly assume regularity conditions such as measurability and finiteness of $w_{nj}(F)$ and now even the same of $w_{nj}(F^2)$ (with $F : X \rightarrow \mathbb{R}$ being an \mathcal{X} -measurable envelope of \mathcal{F})

As already remarked in 3.1, this implies that the sample paths of S_n are contained in the Banachspace

$$l^\infty(\mathcal{F}) := \{x : \mathcal{F} \rightarrow \mathbb{R} : \|x\|_{\mathcal{F}} := \sup_{f \in \mathcal{F}} |x(f)| < \infty\}$$

endowed with the sup-norm $\|\cdot\|_{\mathcal{F}}$, and it also implies in view of the condition (7.1.4) imposed in our FCLT 7.1.3 below that also $\sup_{f \in \mathcal{F}} \mathbb{E}(|S_n(f)|) < \infty$ for sufficiently large n .

Thus, for sufficiently large n , the processes $S_n - \mathbb{E}(S_n)$ can be viewed as r.q.'s in $S := (l^\infty(\mathcal{F}), \|\cdot\|_{\mathcal{F}})$, and to obtain a FCLT for $S_n - \mathbb{E}(S_n)$ amounts to present further sufficient conditions on \mathcal{F} and on both triangular arrays (w_{nj}) and (ξ_{nj}) under which

$$S_n - \mathbb{E}(S_n) \xrightarrow{\mathcal{L}} \mathbb{G} \quad \text{in } S = l^\infty(\mathcal{F})$$

in the sense of (2.3.2) with a limiting re $\mathbb{G} = (G(f))_{f \in \mathcal{F}}$ in $(S, \mathcal{B}(S))$ being a mean-zero Gaussian process.

If, in addition, \mathbb{G} is separable, we write as in 2.3 $\xrightarrow[\text{sep}]{\mathcal{L}}$ instead of $\xrightarrow{\mathcal{L}}$. We will focus here on

$$(7.1.1) \quad S_n - \mathbb{E}(S_n) \xrightarrow[\text{sep}]{\mathcal{L}} \mathbb{G} \quad \text{in } l^\infty(\mathcal{F})$$

with \mathbb{G} having all its sample paths in the subspace $U^b(\mathcal{F}, d)$ of S , where

$$U^b(\mathcal{F}, d) := \{x \in l^\infty(\mathcal{F}) : x \text{ uniformly } d\text{-continuous}\},$$

in order to apply our Characterization Theorem of \mathcal{L} -Convergence 2.3.9 with d being a pseudo-metric on \mathcal{F} such that (\mathcal{F}, d) is totally bounded.

Remember that $U^b(\mathcal{F}, d)$ is a separable subspace of S if and only if (\mathcal{F}, d) is totally bounded ([Gae90], Corollary 2).

Before focussing on (7.1.1), some general comments are in order in comparing our $\xrightarrow[\text{sep}]{\mathcal{L}}$ -convergence with related concepts found in the literature (see e.g. [Va96]):

For this, let $\eta_n : \Omega \rightarrow l^\infty(\mathcal{F}), n \geq 1$, be arbitrary r.q.'s with $\eta_n \xrightarrow[\text{sep}]{\mathcal{L}} \mathbb{G}$, where \mathbb{G} has all its sample paths in some separable subspace S_0 of $l^\infty(\mathcal{F})$. Then the law $\mathcal{L}\{\mathbb{G}\}$ of \mathbb{G} is a *Radon measure* on $\mathcal{B}(l^\infty(\mathcal{F}))$, i.e. for each $B \in \mathcal{B}(l^\infty(\mathcal{F}))$

$$\mathcal{L}\{\mathbb{G}\}(B) = \sup\{\mathcal{L}\{\mathbb{G}\}(K) : K \subset B, K \text{ compact}\}.$$

To see this, note that according to [Bi68], p.9,

$$\mathcal{L}\{\mathbb{G}\} \text{ Radon measure} \iff \mathcal{L}\{\mathbb{G}\} \text{ tight}$$

(i.e. $\forall \varepsilon > 0 \exists K = K_\varepsilon \subset l^\infty(\mathcal{F}), K$ compact, s.t. $\mathcal{L}\{\mathbb{G}\}(K) \geq 1 - \varepsilon$). So it remains to show that $\mathfrak{S} := \mathcal{L}\{\mathbb{G}\}$ is tight:

For this, let D be a countable and dense subset of S_0 ; let $j \in \mathbb{N}$ and $\varepsilon > 0$ be arbitrary. Then the open balls $B(x, \frac{1}{j}) \subset l^\infty(\mathcal{F}), x \in D$, (with center x and radius $\frac{1}{j}$) form a cover of S_0 and therefore (due to the σ -continuity of \mathfrak{S}) there exist $x_1, \dots, x_{n_j} \in D$ such that

$$\mathfrak{S}\left(\bigcup_{i=1}^{n_j} B(x_i, \frac{1}{j})\right) \geq 1 - \varepsilon/2^j.$$

Put $G_j := \bigcup_{i=1}^{n_j} B(x_i, \frac{1}{j})$; then $\bigcap_{j \in \mathbb{N}} G_j$ is totally bounded and $\mathfrak{S}(\bigcap_{j \in \mathbb{N}} G_j) = 1 - \mathfrak{S}(\bigcup_{j \in \mathbb{N}} \mathcal{C}G_j) \geq 1 - \sum_{j \in \mathbb{N}} \mathfrak{S}(\mathcal{C}G_j) \geq 1 - \varepsilon$. Since also $K := (\bigcap_{j \in \mathbb{N}} G_j)^c$ is totally bounded and complete (as a closed subset of the complete space $l^\infty(\mathcal{F})$), K is compact with $\mathfrak{S}(K) \geq 1 - \varepsilon$, which proves tightness since $\varepsilon > 0$ was chosen arbitrary.

On the other hand, if $\mathcal{L}\{\mathbb{G}\}$ is a Radon measure, whence tight, and if $\eta_n \xrightarrow[\text{sep}]{\mathcal{L}} \mathbb{G}$ in the sense of (2.3.2) (with $S = l^\infty(\mathcal{F})$), it follows that there exists a stochastic process $\bar{\mathbb{G}} = (\bar{G}(f))_{f \in \mathcal{F}}$ defined on an appropriate p-space $(\bar{\Omega}, \bar{\mathcal{A}}, \bar{\mathbb{P}})$ with sample paths in a separable subspace S_0 of $l^\infty(\mathcal{F})$ such that $\eta_n \xrightarrow[\text{sep}]{\mathcal{L}} \bar{\mathbb{G}}$, where $\bar{\mathbb{G}} \stackrel{\mathcal{L}}{\underset{\text{fidi}}{=}} \mathbb{G}$:

In fact, $\mathcal{L}\{\mathbb{G}\} \text{ tight} \implies S_0 := \text{supp}\mathcal{L}\{\mathbb{G}\}$ σ -compact and therefore separable; then, taking $(\bar{\Omega}, \bar{\mathcal{A}}, \bar{\mathbb{P}}) := (S_0, \mathcal{B}(S_0), \mathcal{L}\{\mathbb{G}\})$ and $\bar{G}(f)(x) := \pi_f(x) := x(f)$ for $x \in S_0$ the assertion follows (see [Gae77], Lemma 7.2.31).

Finally, let us mention also (without proof) the following result (see [Va96], Section 1.12, and [Gi97], Corollary 1.5):

Let $\eta_n : \Omega \rightarrow l^\infty(\mathcal{F}), n \geq 1$, be arbitrary r.q.'s, $\eta_0 : \Omega \rightarrow l^\infty(\mathcal{F})$ be $\mathcal{A}, \mathcal{B}(l^\infty(\mathcal{F}))$ -measurable with $\mathcal{L}(\eta_0)$ being tight; then

$$(7.1.2) \quad \eta_n \xrightarrow{\mathcal{L}} \eta_0 \text{ in the sense of (2.3.2) (with } S = l^\infty(\mathcal{F})) \iff d_{BL}(\eta_n, \eta_0) \rightarrow 0,$$

where $d_{BL}(\eta_n, \eta_0) := \sup\{|\mathbb{E}^*(H(\eta_n)) - \mathbb{E}(H(\eta_0))| : H \in BL_1(l^\infty(\mathcal{F}))\}$ with

$$BL_1(l^\infty(\mathcal{F})) := \left\{ H : l^\infty(\mathcal{F}) \rightarrow \mathbb{R} : \sup_{x \in l^\infty(\mathcal{F})} |H(x)| \leq 1, \sup_{x, y \in l^\infty(\mathcal{F}), x \neq y} \frac{|H(x) - H(y)|}{\|x - y\|_{\mathcal{F}}} \leq 1 \right\}.$$

Now, the Functional Central Limit Theorem (FCLT) for Random Measure Processes (RMP's) reads as follows (cf. [Zi97], Theorem 6.1 together with Remark 6.2):

7.1.3 THEOREM (FCLT for RMP's).

Let $X = (X, \mathcal{X})$ be an arbitrary measurable space and \mathcal{F} be a class of \mathcal{X} -measurable functions $f : X \rightarrow \mathbb{R}$ with \mathcal{X} -measurable envelope $F : X \rightarrow \mathbb{R}$ (supposed to be countable to avoid measurability considerations). Assume that \mathcal{F} has uniformly integrable L_2 -entropy (cf. 4.3.20) and that there is some pseudometric d on \mathcal{F} such that (\mathcal{F}, d) is totally bounded. Assume further that the following conditions (7.1.4) – (7.1.6) are fulfilled:

For each $\rho > 0$ there exists $\delta_n = \delta_n(\rho) > 0, n \in \mathbb{N}$, with $\delta_n \rightarrow 0$ such that

$$(7.1.4) \quad \limsup_{n \rightarrow \infty} \sum_{j \leq j(n)} \mathbb{E} \left(w_{nj}(F) |\xi_{nj}| \cdot I(w_{nj}(F) |\xi_{nj}| > \delta_n) \right) \leq \rho$$

$$(7.1.5) \quad \lim_{\alpha \rightarrow 0} \limsup_{n \rightarrow \infty} \sup_{d(f, g) \leq \alpha} \sum_{j \leq j(n)} \mathbb{E} \left((w_{nj}(f) - w_{nj}(g))^2 \xi_{nj}^2 \cdot I(w_{nj}(F) |\xi_{nj}| \leq \delta_n) \right) = 0$$

$$(7.1.6) \quad \sup_{n \in \mathbb{N}} \sum_{j \leq j(n)} \mathbb{E} \left(w_{nj}(F^2) \xi_{nj}^2 \cdot I(w_{nj}(F) |\xi_{nj}| \leq \delta_n) \right) < \infty.$$

Assume in addition, that there exists a mean-zero Gaussian process $\bar{\mathbb{G}} = (\bar{G}(f))_{f \in \mathcal{F}}$ such that $S_n - \mathbb{E}(S_n) \xrightarrow[\text{fidi}]{\mathcal{L}} \bar{\mathbb{G}}$.

Then there exists a mean zero Gaussian process $\mathbb{G} = (G(f))_{f \in \mathcal{F}}$ with sample paths in $U^b(\mathcal{F}, d)$ (being a separable subspace of $(l^\infty(\mathcal{F}), \|\cdot\|_{\mathcal{F}})$ such that

$$(7.1.7) \quad S_n - \mathbb{E}(S_n) \xrightarrow[\text{sep}]{\mathcal{L}} \mathbb{G} \quad \text{in } l^\infty(\mathcal{F}) \quad \text{and} \quad \bar{\mathbb{G}} \xrightarrow[\text{fidi}]{\mathcal{L}} \mathbb{G}.$$

PROOF. Concerning (7.1.7) we remark (as already mentioned above) that by (7.1.4) for sufficiently large n

$$\begin{aligned} \sup_{f \in \mathcal{F}} \mathbb{E}(|S_n(f)|) &\leq \sum_{j \leq j(n)} \mathbb{E}(w_{nj}(F) |\xi_{nj}|) \leq \\ &\sum_{j \leq j(n)} \mathbb{E} \left(w_{nj}(F) |\xi_{nj}| \cdot I(w_{nj}(F) |\xi_{nj}| > \delta_n) \right) + j(n) \delta_n < \infty. \end{aligned}$$

Now, since (\mathcal{F}, d) is assumed to be totally bounded and since $S_n - \mathbb{E}(S_n) \xrightarrow[\text{fidi}]{\mathcal{L}} \bar{\mathbb{G}}$ by assumption, it follows in view of our CT \mathcal{L} -C 2.3.9 together with Remark 2.3.19 that it remains to show

$$(a) \quad \lim_{\alpha \rightarrow 0} \limsup_{n \rightarrow \infty} \mathbb{E} \left(\sup_{d(f, g) \leq \alpha} |S_n(f) - S_n(g) - (\mathbb{E}(S_n(f)) - \mathbb{E}(S_n(g)))| \right) = 0.$$

For this, according to the Symmetrization Inequality 5.1.2 it suffices to show

$$(b) \quad \lim_{\alpha \rightarrow 0} \limsup_{n \rightarrow \infty} \mathbb{E} \left(\sup_{d(f, g) \leq \alpha} \left| \sum_{j \leq j(n)} \varepsilon_j \xi_{nj} \cdot (w_{nj}(f) - w_{nj}(g)) \right| \right) = 0,$$

where $(\varepsilon_j)_{j \in \mathbb{N}}$ is a canonically formed Rademacher sequence being independent of both arrays (w_{nj}) and (ξ_{nj}) .

Let $\rho > 0$ be arbitrary and $\delta_n = \delta_n(\rho) > 0, n \in \mathbb{N}$, with $\delta_n \rightarrow 0$, fulfilling (7.1.4) – (7.1.6). Then

$$\begin{aligned} & \mathbb{E}\left(\sup_{d(f,g) \leq \alpha} \left| \sum_{j \leq j(n)} \varepsilon_j \xi_{nj} \cdot (w_{nj}(f) - w_{nj}(g)) \right|\right) \\ & \leq \mathbb{E}\left(\sup_{d(f,g) \leq \alpha} \left| \sum_{j \leq j(n)} \varepsilon_j \xi_{nj} \cdot (w_{nj}(f) - w_{nj}(g)) \cdot I(w_{nj}(F)|\xi_{nj}| \leq \delta_n) \right|\right) \\ & \quad + 2 \sum_{j \leq j(n)} \mathbb{E}\left(w_{nj}(F)|\xi_{nj}| \cdot I(w_{nj}(F)|\xi_{nj}| > \delta_n)\right), \end{aligned}$$

and so, because of (7.1.4), it remains to show

$$(c) \quad \lim_{\alpha \rightarrow 0} \limsup_{n \rightarrow \infty} \mathbb{E}\left(\sup_{d(f,g) \leq \alpha} \left| \sum_{j \leq j(n)} \varepsilon_j \xi_{nj} (w_{nj}(f) - w_{nj}(g)) \cdot I(w_{nj}(F)|\xi_{nj}| \leq \delta_n) \right|\right) = 0.$$

For this, let, for $f, g \in \mathcal{F}$,

$$\sigma_{n\delta_n}^2(f, g) := \sum_{j \leq j(n)} \mathbb{E}\left((w_{nj}(f) - w_{nj}(g))^2 \xi_{nj}^2 \cdot I(w_{nj}(F)|\xi_{nj}| \leq \delta_n)\right).$$

With this definition of $\sigma_{n\delta_n}$ condition (7.1.5) reads as follows:

$$(d) \quad \lim_{\beta \rightarrow 0} \limsup_{n \rightarrow \infty} \sup_{d(f,g) \leq \beta} \sigma_{n\delta_n}^2(f, g) = 0.$$

But (d) allows us to switch in (c) from the pseudo-metric d to $\sigma_{n\delta_n}$, i.e. in doing so we have to show

$$(e) \quad \lim_{\alpha \rightarrow 0} \limsup_{n \rightarrow \infty} \mathbb{E}\left(\sup_{\sigma_{n\delta_n}(f,g) \leq \alpha} \left| \sum_{j \leq j(n)} \varepsilon_j \xi_{nj} (w_{nj}(f) - w_{nj}(g)) \cdot I(w_{nj}(F)|\xi_{nj}| \leq \delta_n) \right|\right) = 0.$$

Now

$$\begin{aligned} \rho_{n\delta_n}^2(f, g) & := \sum_{j \leq j(n)} (w_{nj}(f) - w_{nj}(g))^2 \xi_{nj}^2 \cdot I(w_{nj}(F)|\xi_{nj}| \leq \delta_n) \\ & \leq \sum_{j \leq j(n)} w_{nj}((f - g)^2) \xi_{nj}^2 \cdot I(w_{nj}(F)|\xi_{nj}| \leq \delta_n) = \tilde{\mu}_{n\delta_n}((f - g)^2) \end{aligned}$$

for all $f, g \in \mathcal{F}$ with

$$\tilde{\mu}_{n\delta_n}(f) := \sum_{j \leq j(n)} w_{nj}(f) \xi_{nj}^2 \cdot I(w_{nj}(F)|\xi_{nj}| \leq \delta_n),$$

where

$$\sigma_{n\delta_n}^2(f, g) = \mathbb{E}(\rho_{n\delta_n}^2(f, g)) \quad \text{for all } f, g \in \mathcal{F}.$$

By this, we arrived at a situation which allows us to apply Ziegler's Maximal Inequality ([Zi97], Theorem 3.1, applied here with $\Phi_{nj}(f) := w_{nj}(f) \xi_{nj}^2 \cdot I(w_{nj}(F)|\xi_{nj}| \leq \delta_n)$) according to which there exist universal constants $0 < K_i < \infty, i = 1, 2$, such that for all $\alpha > 0$

$$(f) \quad \mathbb{E}\left(\sup_{\sigma_{n\delta_n}(f,g) \leq \alpha} \left| \sum_{j \leq j(n)} \varepsilon_j \xi_{nj} \cdot (w_{nj}(f) - w_{nj}(g)) \cdot I(w_{nj}(F)|\xi_{nj}| \leq \delta_n) \right|\right) \\ \leq K_1 \cdot A(n, \alpha) \cdot B(n) + K_2 \cdot C(n, \alpha)$$

with

$$A(n, \alpha) := \alpha^{-1} \mathbb{E}^* \frac{1}{2} \left(\max_{j \leq j(n)} \sup_{f, g \in \mathcal{F}} |\xi_{nj}(w_{nj}(f) - w_{nj}(g))| \cdot I(w_{nj}(F) | \xi_{nj} | \leq \delta_n) \cdot [\tilde{\mu}_{n\delta_n}(F^2)]^{1/2} \cdot l_n(1) \right)$$

$$B(n) := \mathbb{E}^* \frac{1}{2} \left(\tilde{\mu}_{n\delta_n}(F^2) (l_n(1))^2 \right)$$

$$\text{and } C(n, \alpha) := \mathbb{E}^* \left(\max\{1, [\tilde{\mu}_{n\delta_n}(F^2)]^{1/2}\} \cdot l_n(\alpha) \right),$$

where $l_n(\alpha)$ is the random integral, defined by

$$l_n(\alpha) := \int_0^\alpha \left(\log N(\tau (\tilde{\mu}_{n\delta_n}(F^2))^{1/2}, \mathcal{F}, d_{\tilde{\mu}_{n\delta_n}}^{(2)}) \right)^{1/2} d\tau.$$

Here, we have according to (7.1.6) that

$$(g) \quad \sup_{n \in \mathbb{N}} \mathbb{E}(\tilde{\mu}_{n\delta_n}(F^2)) = \sum_{j \leq j(n)} \mathbb{E} \left(w_{nj}(F^2) \xi_{nj}^2 \cdot I(w_{nj}(F) | \xi_{nj} | \leq \delta_n) \right) < \infty,$$

whence $\tilde{\mu}_{n\delta_n} \in \mathcal{M}(X, F)$ for all $n \in \mathbb{N}$ a.s., and thus a.s.

$$(h) \quad l_n(1) \leq \int_0^\infty \left(\log [\sup_{\nu \in \mathcal{M}(X, F)} N(\tau (\nu(F^2))^{1/2}, \mathcal{F}, d_\nu^{(2)})] \right)^{1/2} d\tau < \infty,$$

since \mathcal{F} has uniformly integrable L_2 -entropy.

The latter also implies that a.s

$$(i) \quad l_n(\alpha) \leq \int_0^\alpha \left(\log [\sup_{\nu \in \mathcal{M}(X, F)} N(\tau (\nu(F^2))^{1/2}, \mathcal{F}, d_\nu^{(2)})] \right)^{1/2} d\tau \longrightarrow 0 \text{ as } \alpha \longrightarrow 0.$$

Now, concerning $A(n, \alpha)$, note that

$$\max_{j \leq j(n)} \sup_{f, g \in \mathcal{F}} |\xi_{nj}(w_{nj}(f) - w_{nj}(g))| \cdot I(w_{nj}(F) | \xi_{nj} | \leq \delta_n) \leq 2 \cdot \delta_n,$$

which implies by (g) and (h) that for all $\alpha > 0$

$$\limsup_{n \rightarrow \infty} A(n, \alpha) \cdot B(n) = 0.$$

Finally, by (g) and (i) we get

$$\lim_{\alpha \rightarrow 0} \limsup_{n \rightarrow \infty} C(n, \alpha) = 0,$$

which completes the proof of (e) according to (f). □

It is easily seen that the conditions (7.1.4) – (7.1.6) become much simpler in case of a uniformly bounded index set \mathcal{F} (with envelope $F \equiv 1$ w.l.o.g.) In this case we obtain immediately from Theorem 7.1.3:

7.1.8 Corollary (cf. [Zi97], Corollary 6.3).

Assume that \mathcal{F} is uniformly bounded and has uniformly integrable L_2 -entropy, and that there is some pseudo-metric d on \mathcal{F} such that (\mathcal{F}, d) is totally bounded. Assume further that the following conditions (7.1.4)' – (7.1.6)' are fulfilled:

$$(7.1.4)' \quad \lim_{n \rightarrow \infty} \sum_{j \leq j(n)} \mathbb{E} \left(|\xi_{nj}| \cdot I(|\xi_{nj}| > \delta) \right) = 0 \quad \text{for all } \delta > 0$$

(Noticing that (7.1.4)' implies the existence of a sequence $(\delta_n)_{n \in \mathbb{N}}$ of positive real numbers δ_n such that $\delta_n \rightarrow 0$ and $\lim_{n \rightarrow \infty} \sum_{j \leq j(n)} \mathbb{E} \left(|\xi_{nj}| \cdot I(|\xi_{nj}| > \delta_n) \right) = 0$.)

$$(7.1.5)' \quad \lim_{\alpha \rightarrow 0} \limsup_{n \rightarrow \infty} \sup_{d(f, g) \leq \alpha} \sum_{j \leq j(n)} \mathbb{E} \left((w_{nj}(f) - w_{nj}(g))^2 \xi_{nj}^2 \cdot I(|\xi_{nj}| \leq \delta_1) \right) = 0 \quad \text{for some } \delta_1 > 0$$

$$(7.1.6)' \quad \sup_{n \in \mathbb{N}} \sum_{j \leq j(n)} \mathbb{E} \left(\xi_{nj}^2 \cdot I(|\xi_{nj}| \leq \delta_2) \right) < \infty \quad \text{for some } \delta_2 > 0$$

(7.1.9) *There exists a mean-zero Gaussian process $\bar{\mathbb{G}} = (\bar{G}(f))_{f \in \mathcal{F}}$ such that*

$$S_n - \mathbb{E}(S_n) \xrightarrow[\text{fidi}]{\mathcal{L}} \bar{\mathbb{G}}.$$

Then there exists a mean-zero Gaussian process $\mathbb{G} = (G(f))_{f \in \mathcal{F}}$ with sample paths in $U^b(\mathcal{F}, d)$ (being a separable subspace of $(l^\infty(\mathcal{F}), \|\cdot\|_{\mathcal{F}})$) such that

$$(7.1.7) \quad S_n - \mathbb{E}(S_n) \xrightarrow[\text{sep}]{\mathcal{L}} \mathbb{G} \quad \text{in } l^\infty(\mathcal{F}) \quad \text{and} \quad \bar{\mathbb{G}} \xrightarrow[\text{fidi}]{\mathcal{L}} \mathbb{G}.$$

where again

$$S_n(f) := \sum_{j \leq j(n)} w_{nj}(f) \cdot \xi_{nj}, \quad f \in \mathcal{F}.$$

Let us consider next the special case where $w_{nj} = \delta_{\eta_{nj}}$, $(\eta_{nj})_{1 \leq j \leq j(n), n \in \mathbb{N}}$ being a triangular array of re's in (X, \mathcal{X}) in order to present tractable conditions under which (7.1.9) holds true.

7.1.10 Corollary (cf. [Zi97], Corollary 6.4).

Let \mathcal{F} be as in Corollary 7.1.8. Let $w_{nj} = \delta_{\eta_{nj}}$ where $(\eta_{nj})_{1 \leq j \leq j(n), n \in \mathbb{N}}$ is a triangular array of re's in (X, \mathcal{X}) with laws $\nu_{nj} := \mathcal{L}\{\eta_{nj}\}$ on \mathcal{X} , and suppose now, in addition to the basic independence assumption for the pairs $(\eta_{n1}, \xi_{n1}), \dots, (\eta_{nj(n)}, \xi_{nj(n)})$, that for each $n \in \mathbb{N}$ and $1 \leq j \leq j(n)$ also η_{nj} and ξ_{nj} are independent. Assume further that there is some p -measure ν on \mathcal{X} and constants

$0 < c_i < \infty$ such that the following four conditions are fulfilled:

$$(7.1.4)' \quad \lim_{n \rightarrow \infty} \sum_{j \leq j(n)} \mathbb{E} \left(|\xi_{nj}| \cdot I(|\xi_{nj}| > \delta) \right) = 0 \quad \text{for all } \delta > 0$$

$$(7.1.11) \quad \lim_{\alpha \rightarrow 0} \limsup_{n \rightarrow \infty} \sup_{d_\nu^{(2)}(f,g) \leq \alpha} \sum_{j \leq j(n)} \nu_{nj}((f-g)^2) \cdot \mathbb{E}(\xi_{nj}^2 \cdot I(|\xi_{nj}| \leq \delta_1)) = 0 \quad \text{for some } \delta_1 > 0$$

$$(7.1.12) \quad \lim_{n \rightarrow \infty} \sum_{j \leq j(n)} \nu_{nj}(f \cdot g) \cdot \mathbb{E}(\xi_{nj}^2 \cdot I(|\xi_{nj}| \leq \delta_2)) = c_1 \nu(f \cdot g) \quad \text{for all } f, g \in \mathcal{F} \text{ and some } \delta_2 > 0$$

$$(7.1.13) \quad \lim_{n \rightarrow \infty} \sum_{j \leq j(n)} \nu_{nj}(f) \cdot \nu_{nj}(g) \left(\mathbb{E}(\xi_{nj} \cdot I(|\xi_{nj}| \leq \delta_3)) \right)^2 = c_2 \nu(f) \cdot \nu(g) \quad \text{for all } f, g \in \mathcal{F} \text{ and some } \delta_3 > 0.$$

Then, with $S_n(f) := \sum_{j \leq j(n)} f(\eta_{nj}) \cdot \xi_{nj}$, $f \in \mathcal{F}$,

$$S_n - \mathbb{E}(S_n) \xrightarrow[\text{sep}]{\mathcal{L}} \mathbb{G}_\nu \quad \text{in } l^\infty(\mathcal{F}),$$

where $\mathbb{G}_\nu = (G_\nu(f))_{f \in \mathcal{F}}$ is a mean zero Gaussian process with sample paths in $U^b(\mathcal{F}, d_\nu^{(2)})$ and $\text{cov}(G_\nu(f), G_\nu(g)) = c_1 \nu(f \cdot g) - c_2 \nu(f) \cdot \nu(g)$ for $f, g \in \mathcal{F}$.

PROOF. Note first that (7.1.5)' coincides with (7.1.11) in the present case since $\mathbb{E} \left((w_{nj}(f) - w_{nj}(g))^2 \xi_{nj}^2 \cdot I(|\xi_{nj}| \leq \delta_1) \right) = \mathbb{E} \left((w_{nj}(f) - w_{nj}(g))^2 \right) \cdot \mathbb{E}(\xi_{nj}^2 \cdot I(|\xi_{nj}| \leq \delta_1)) \stackrel{(w_{nj} = \delta_{\eta_{nj}})}{=} \nu_{nj}((f-g)^2) \cdot \mathbb{E}(\xi_{nj}^2 \cdot I(|\xi_{nj}| \leq \delta_1))$ for each n and $1 \leq j \leq j(n)$. Secondly, assuming w.l.o.g. $F \equiv 1 \in \mathcal{F}$, (7.1.12) (with $f = g = F \equiv 1$) implies (7.1.6)'. Therefore, the assertion follows from Corollary 7.1.8, since under the present conditions one can verify (7.1.9) in the same way as it was done (in the set-indexed case) within the proof of Theorem 2.2 in [Gae94], part (a). \square

7.2 FCLT's for partial-sum processes with either fixed or random locations

Let $X = (X, \mathcal{X})$ be an arbitrary measurable space, $\mathcal{C} \subset \mathcal{X}$ a countable VCC being w.l.o.g. closed under the formation of symmetric differences (cf. 4.2.7). Note that $\mathcal{F} := \{1_C : C \in \mathcal{C}\}$ has uniformly integrable L_2 -entropy according to 4.3.21.

Let $w_{nj} = \delta_{\eta_{nj}}$, $(\eta_{nj})_{1 \leq j \leq j(n), n \in \mathbb{N}}$ being a triangular array of re's in (X, \mathcal{X}) (with $j(n) \rightarrow \infty$ as $n \rightarrow \infty$) and $(\xi_{nj})_{1 \leq j \leq j(n), n \in \mathbb{N}}$ a triangular array of rv's such that for each $n \in \mathbb{N}$ the sequence of pairs $(\eta_{n1}, \xi_{n1}), \dots, (\eta_{nj(n)}, \xi_{nj(n)})$ is independent but not necessarily identically distributed (and where the

components within each pair need not be independent). Let $d := d_\nu$ for some p -measure ν on \mathcal{X} (where $d_\nu(C, D) := \nu(C\Delta D) = d_\nu^{(2)}(1_C, 1_D)$ for $C, D \in \mathcal{C}$); note that (\mathcal{C}, d_ν) is totally bounded (cf. 4.2.3). Then, specializing Corollary 7.1.8 to the present case, we obtain the following result for partial-sum processes $S_n = (S_n(C))_{C \in \mathcal{C}}$ with random locations as introduced in section 3.2.1, i.e. with

$$S_n(C) := \sum_{j \leq j(n)} 1_C(\eta_{nj}) \cdot \xi_{nj} \quad , \quad C \in \mathcal{C} :$$

7.2.1 THEOREM (cf. [Gae94], Theorem 2.11).

Assume that the following conditions are fulfilled:

$$(7.1.4)' \quad \lim_{n \rightarrow \infty} \sum_{j \leq j(n)} \mathbb{E}(|\xi_{nj}| \cdot I(|\xi_{nj}| > \delta)) = 0 \text{ for all } \delta > 0$$

$$(7.2.2) \quad \lim_{\alpha \rightarrow 0} \limsup_{n \rightarrow \infty} \sup_{C \in \mathcal{C}, \nu(C) \leq \alpha} \sum_{j \leq j(n)} \mathbb{E}(1_C(\eta_{nj}) \xi_{nj}^2 \cdot I(|\xi_{nj}| \leq \delta_1)) = 0 \text{ for some } \delta_1 > 0$$

$$(7.1.6)' \quad \sup_{n \in \mathbb{N}} \sum_{j \leq j(n)} \mathbb{E}(\xi_{nj}^2 \cdot I(|\xi_{nj}| \leq \delta_2)) < \infty \text{ for some } \delta_2 > 0$$

$$(7.1.9)' \quad \text{There exists a mean-zero Gaussian process } \bar{\mathbb{G}} = (\bar{G}(C))_{C \in \mathcal{C}} \text{ such that} \\ S_n - \mathbb{E}(S_n) \xrightarrow[\text{fidi}]{} \bar{\mathbb{G}}.$$

Then there exists a mean-zero Gaussian process $\mathbb{G} = (G(C))_{C \in \mathcal{C}}$ with sample paths in $U^b(\mathcal{C}, d_\nu)$ (being a separable subspace of $(l^\infty(\mathcal{C}), \|\cdot\|_{\mathcal{C}})$) such that

$$S_n - \mathbb{E}(S_n) \xrightarrow[\text{sep}]{} \mathbb{G} \quad \text{in } l^\infty(\mathcal{C}) \quad \text{and} \quad \bar{\mathbb{G}} \xrightarrow[\text{fidi}]{} \mathbb{G}.$$

Specializing Corollary 7.1.10 in the same way as just done with Corollary 7.1.8 to the set-indexed case yields the following result for $S_n = (S_n(C))_{C \in \mathcal{C}}$ with

$$S_n(C) := \sum_{j \leq j(n)} 1_C(\eta_{nj}) \cdot \xi_{nj} \quad , \quad C \in \mathcal{C},$$

under the additional assumption that for each $n \in \mathbb{N}$ and $1 \leq j \leq j(n)$ also η_{nj} and ξ_{nj} are independent.

7.2.3 THEOREM (cf. [Gae94], Theorem 2.2).

Suppose that there is some p -measure ν on \mathcal{X} and constants $0 < c_i < \infty$ such that the following four

conditions are fulfilled:

$$(7.1.4)' \quad \lim_{n \rightarrow \infty} \sum_{j \leq j(n)} \mathbb{E} \left(|\xi_{nj}| \cdot I(|\xi_{nj}| > \delta) \right) = 0 \quad \text{for all } \delta > 0$$

$$(7.2.4) \quad \lim_{\alpha \rightarrow 0} \limsup_{n \rightarrow \infty} \sup_{C \in \mathcal{C}: \nu(C) \leq \alpha} \sum_{j \leq j(n)} \nu_{nj}(C) \cdot \mathbb{E}(\xi_{nj}^2 \cdot I(|\xi_{nj}| \leq \delta_1)) = 0 \quad \text{for some } \delta_1 > 0$$

$$(7.2.5) \quad \lim_{n \rightarrow \infty} \sum_{j \leq j(n)} \nu_{nj}(C \cap D) \cdot \mathbb{E}(\xi_{nj}^2 \cdot I(|\xi_{nj}| \leq \delta_2)) = c_1 \nu(C \cap D) \quad \text{for all } C, D \in \mathcal{C} \text{ and some } \delta_2 > 0$$

$$(7.2.6) \quad \lim_{n \rightarrow \infty} \sum_{j \leq j(n)} \nu_{nj}(C) \cdot \nu_{nj}(D) \left(\mathbb{E}(\xi_{nj} \cdot I(|\xi_{nj}| \leq \delta_3)) \right)^2 = c_2 \nu(C) \cdot \nu(D) \quad \text{for all } C, D \in \mathcal{C} \text{ and some } \delta_3 > 0.$$

Then

$$S_n - \mathbb{E}(S_n) \xrightarrow[\text{sep}]{\mathcal{L}} \mathbb{G}_\nu \quad \text{in } l^\infty(\mathcal{F}),$$

where $\mathbb{G} = (G(C))_{C \in \mathcal{C}}$ is a mean-zero Gaussian process with sample paths in $U^b(\mathcal{C}, d_\nu)$ and $\text{cov}(G_\nu(C), G_\nu(D)) = c_1 \nu(C \cap D) - c_2 \nu(C) \cdot \nu(D)$ for $C, D \in \mathcal{C}$.

From Theorem 7.2.3 we get the following result which was already mentioned in section 2 (see Theorem 2.2.3) and used at the end of section 2.3.6.

7.2.7 Corollary (cf. [Gae94], Theorem 2.15).

Let $\xi_{nj} = j(n)^{-1} \xi_j$ for each $1 \leq j \leq j(n)$ and $n \in \mathbb{N}$ (with $j(n) \rightarrow \infty$ as $n \rightarrow \infty$), the ξ_j 's being i.i.d. rv's with $\mathbb{E}(\xi_1) = 0$ and $\mathbb{E}(\xi_1^2) = 1$. Let $(\eta_{nj})_{1 \leq j \leq j(n), n \in \mathbb{N}}$ being a triangular array of rowwise independent but not necessarily identically distributed re's in (X, \mathcal{X}) which is independent of the sequence $(\xi_j)_{j \in \mathbb{N}}$. Suppose that there is some p -measure ν on \mathcal{X} such that the following two conditions are fulfilled (with $\nu_{nj} := \mathcal{L}\{\eta_{nj}\}$):

$$(i) \quad \lim_{n \rightarrow \infty} j(n)^{-1} \sum_{j \leq j(n)} \nu_{nj}(C \cap D) = \nu(C \cap D) \quad \text{for all } C, D \in \mathcal{C}$$

$$(ii) \quad \lim_{\alpha \rightarrow 0} \limsup_{n \rightarrow \infty} \sup_{C \in \mathcal{C}: \nu(C) \leq \alpha} j(n)^{-1} \sum_{j \leq j(n)} \nu_{nj}(C) = 0.$$

Then

$$\left(j(n)^{-1/2} \sum_{j \leq j(n)} 1_C(\eta_{nj}) \cdot \xi_j \right)_{C \in \mathcal{C}} \xrightarrow[\text{sep}]{\mathcal{L}} \mathbb{G}_\nu,$$

where $\mathbb{G}_\nu = (G_\nu(C))_{C \in \mathcal{C}}$ is a mean-zero Gaussian process with sample paths in $U^b(\mathcal{C}, d_\nu)$ and $\text{cov}(G_\nu(C), G_\nu(D)) = \nu(C \cap D)$ for $C, D \in \mathcal{C}$.

PROOF. According to Theorem 7.2.3 we have to verify the conditions (7.1.4)', (7.2.4), (7.2.5) with $c_1 = 1$ and (7.2.6) with $c_2 = 0$ to get the assertion of 7.2.7.

As to (7.1.4)': For each $\delta > 0$ we have $\sum_{j \leq j(n)} \mathbb{E}(|\xi_{nj}| \cdot I(|\xi_{nj}| > \delta)) \leq \delta^{-1} \sum_{j \leq j(n)} \mathbb{E}(\xi_{nj}^2 \cdot I(|\xi_{nj}| > \delta)) = \delta^{-1} \mathbb{E}(\xi_1^2 \cdot I(|\xi_1| > \delta j(n)^{1/2})) \rightarrow 0$, since $\mathbb{E}(\xi_1^2) < \infty$.

As to (7.2.5): $\sum_{j \leq j(n)} \nu_{nj}(C \cap D) \cdot \mathbb{E}(\xi_{nj}^2 \cdot I(|\xi_{nj}| \leq \delta_2)) = [j(n)^{-1} \sum_{j \leq j(n)} \nu_{nj}(C \cap D)] \cdot \mathbb{E}(\xi_1^2 \cdot I(|\xi_1| \leq \delta_2 j(n)^{1/2}))$, where by (i) $\lim_{n \rightarrow \infty} j(n)^{-1} \sum_{j \leq j(n)} \nu_{nj}(C \cap D) = \nu(C \cap D)$ and $\lim_{n \rightarrow \infty} \mathbb{E}(\xi_1^2 \cdot I(|\xi_1| \leq \delta_2 j(n)^{1/2})) = \mathbb{E}(\xi_1^2) = 1$. This proves (7.2.5) with $c_1 = 1$.

As to (7.2.6): Since $\limsup_{n \rightarrow \infty} \sum_{j \leq j(n)} \nu_{nj}(C) \cdot \nu_{nj}(D) \cdot \left(\mathbb{E}(\xi_{nj} \cdot I(|\xi_{nj}| \leq \delta_3)) \right)^2 \leq \limsup_{n \rightarrow \infty} \sum_{j \leq j(n)} \left(\mathbb{E}(\xi_{nj} \cdot I(|\xi_{nj}| \leq \delta_3)) \right)^2 = \lim_{n \rightarrow \infty} \left(\mathbb{E}(\xi_1 \cdot I(|\xi_1| \leq \delta_3 j(n)^{1/2})) \right)^2 = \left(\mathbb{E}(\xi_1) \right)^2 = 0$, we get (7.2.6) with $c_2 = 0$.

As to (7.2.4): Since $\sum_{j \leq j(n)} \nu_{nj}(C) \cdot \mathbb{E}(\xi_{nj}^2 \cdot I(|\xi_{nj}| \leq \delta_1)) = [j(n)^{-1} \sum_{j \leq j(n)} \nu_{nj}(C)] \cdot \mathbb{E}(\xi_1^2 \cdot I(|\xi_1| \leq \delta_1 j(n)^{1/2}))$, it follows that

$$\sup_{C \in \mathcal{C}, \nu(C) \leq \alpha} \sum_{j \leq j(n)} \nu_{nj}(C) \cdot \mathbb{E}(\xi_{nj}^2 \cdot I(|\xi_{nj}| \leq \delta_1)) = \left[\sup_{C \in \mathcal{C}, \nu(C) \leq \alpha} j(n)^{-1} \sum_{j \leq j(n)} \nu_{nj}(C) \right] \cdot \mathbb{E}(\xi_1^2 \cdot I(|\xi_1| \leq \delta_1 j(n)^{1/2})),$$

whence by (ii) and the fact that $\lim_{n \rightarrow \infty} \mathbb{E}(\xi_1^2 \cdot I(|\xi_1| \leq \delta_1 j(n)^{1/2})) = \mathbb{E}(\xi_1^2) = 1$ condition (7.2.4) is also fulfilled. \square

NOTE: Corollary 7.2.7 can also be proved more directly by application of Corollary 7.1.8.

Considering as in 6.2.8 function-indexed partial-sum processes $S_n = (S_n(f))_{f \in \mathcal{F}}$, defined by

$$S_n(f) := j(n)^{-1} \sum_{j \leq j(n)} f(\eta_{nj}) \cdot \xi_j, \quad f \in \mathcal{F},$$

\mathcal{F} being countable, uniformly bounded, having uniformly integrable L_2 -entropy (whence (\mathcal{F}, d) is totally bounded w.r.t. $d = d_\nu^{(2)}$ for each p-measure ν on \mathcal{X} according to 4.3.21), Corollary 7.1.10 yields the following result (cf. [Zi97], 7.2):

7.2.8 THEOREM.

Let $(\eta_{nj})_{1 \leq j \leq j(n), n \in \mathbb{N}}$ being a triangular array of rowwise independent (but not necessarily identically distributed) re's in (X, \mathcal{X}) , $(\xi_j)_{j \in \mathbb{N}}$ be a sequence of iid rv's ξ_j with $\mathbb{E}(\xi_1) = 0$ and $\mathbb{E}(\xi_1^2) = 1$, such that the whole array (η_{nj}) is independent of the sequence (ξ_j) . Suppose that there is some p-measure ν on \mathcal{X} such that the following conditions are fulfilled (again with $\nu_{nj} := \mathcal{L}\{\eta_{nj}\}$):

$$(7.2.9) \quad \lim_{n \rightarrow \infty} j(n)^{-1} \sum_{j \leq j(n)} \nu_{nj}(f \cdot g) = \nu(f \cdot g) \quad \text{for all } f, g \in \mathcal{F}$$

$$(7.2.10) \quad \lim_{\alpha \rightarrow 0} \limsup_{n \rightarrow \infty} \sup_{d_\nu^{(2)}(f, g) \leq \alpha} j(n)^{-1} \sum_{j \leq j(n)} \nu_{nj}((f - g)^2) = 0.$$

Then

$$\left(j(n)^{-1/2} \sum_{j \leq j(n)} f(\eta_{nj}) \cdot \xi_j \right)_{f \in \mathcal{F}} \xrightarrow[\text{sep}]{\mathcal{L}} \mathbb{G}_\nu \quad \text{in } l^\infty(\mathcal{F}),$$

where $\mathbb{G}_\nu = (G_\nu(f))_{f \in \mathcal{F}}$ is a mean-zero Gaussian process with sample paths in $U^b(\mathcal{F}, d_\nu^{(2)})$ and $\text{cov}(G_\nu(f), G_\nu(g)) = \nu(f \cdot g)$ for $f, g \in \mathcal{F}$.

PROOF. The assertion follows from Corollary 7.1.10 in an analogous way as in the proof of 7.2.7. \square

Concerning on the other hand partial-sum processes $S_n = (S_n(f))_{f \in \mathcal{F}}$ with

$$S_n(f) := \sum_{j \leq j(n)} f(\eta_j) \cdot \xi_{nj}, \quad f \in \mathcal{F},$$

where $\eta_j, j \in \mathbb{N}$, are iid re's in (X, \mathcal{X}) with $\mathcal{L}\{\eta_j\} = \nu$, and where $(\xi_{nj})_{1 \leq j \leq j(n), n \in \mathbb{N}}$ (with $j(n) \rightarrow \infty$ as $n \rightarrow \infty$) is a triangular array of rowwise independent (but not necessarily identically distributed) rv's such that the whole array (ξ_{nj}) is independent of the sequence (η_j) , the following result is mentioned in [Zi97], 4.4:

7.2.11 THEOREM.

Let $\mathbb{E}(\xi_{nj}) = 0$ for all $1 \leq j \leq j(n)$ and $n \in \mathbb{N}$. Assume that \mathcal{F} has uniformly integrable L_2 -entropy and that $\nu(F^2) < \infty$, where F denotes the envelope of \mathcal{F} . Suppose that the following conditions are fulfilled:

$$(i) \quad \lim_{n \rightarrow \infty} \sum_{j \leq j(n)} \mathbb{E} \left(F^2(\eta_j) \xi_{nj}^2 \cdot I(F(\eta_j) |\xi_{nj}| > \delta) \right) = 0 \quad \text{for all } \delta > 0$$

(Lindeberg-type condition)

$$(ii) \quad \lim_{n \rightarrow \infty} \sum_{j \leq j(n)} \mathbb{E}(\xi_{nj}^2) = 1.$$

Then

$$S_n \xrightarrow[\text{sep}]{\mathcal{L}} \mathbb{G}_\nu \quad \text{in } l^\infty(\mathcal{F}),$$

where $\mathbb{G}_\nu = (G_\nu(f))_{f \in \mathcal{F}}$ is a mean-zero Gaussian process with sample paths in $U^b(\mathcal{F}, d_\nu^{(2)})$ and $\text{cov}(G_\nu(f), G_\nu(g)) = \nu(f \cdot g)$ for $f, g \in \mathcal{F}$.

PROOF. We are going to apply Theorem 7.1.3 with $w_{nj} = \delta_{\eta_j}$ and $d = d_\nu^{(2)}$. For thist, one has to verify that $S_n \xrightarrow[\text{fidi}]{\mathcal{L}} \mathbb{G}_\nu$, but this follows from the classical multivariate CLT for triangular arrays. So it remains to verify (7.1.4) – (7.1.6):

As to (7.1.4): $\sum_{j \leq j(n)} \mathbb{E} \left(w_{nj}(F) |\xi_{nj}| \cdot I(w_{nj}(F) |\xi_{nj}| > \delta_n) \right) = \sum_{j \leq j(n)} \mathbb{E} \left(F(\eta_j) |\xi_{nj}| \cdot I(F(\eta_j) |\xi_{nj}| > \delta_n) \right) \leq \delta_n^{-1} \sum_{j \leq j(n)} \mathbb{E} \left(F^2(\eta_j) \xi_{nj}^2 \cdot I(F(\eta_j) |\xi_{nj}| > \delta_n) \right) \rightarrow 0$ with an appropriate chosen sequence $(\delta_n)_{n \in \mathbb{N}} \subset \mathbb{R}_+$ with $\delta_n \rightarrow 0$, since by (i)

$$\lim_{n \rightarrow \infty} \delta_n^{-1} \sum_{j \leq j(n)} \mathbb{E} \left(F^2(\eta_j) \xi_{nj}^2 \cdot I(F(\eta_j) |\xi_{nj}| > \delta) \right) = 0 \quad \text{for all } \delta > 0.$$

As to (7.1.6): $\sup_{n \in \mathbb{N}} \sum_{j \leq j(n)} \mathbb{E} \left(w_{nj}(F^2) \xi_{nj}^2 \cdot I(w_{nj}(F) | \xi_{nj}| \leq \delta_n) \right) \leq \sup_{n \in \mathbb{N}} \sum_{j \leq j(n)} \mathbb{E}(F^2(\eta_j)) \cdot \mathbb{E}(\xi_{nj}^2)$
 $= \nu(F^2) \cdot \sup_{n \in \mathbb{N}} \sum_{j \leq j(n)} \mathbb{E}(\xi_{nj}^2) < \infty$ by (ii), since $\nu(F^2) < \infty$.

As to (7.1.5) (with $d = d_\nu^{(2)}$): $\sup_{d_\nu^{(2)}(f,g) \leq \alpha} \sum_{j \leq j(n)} \mathbb{E} \left((w_{nj}(f) - w_{nj}(g))^2 \xi_{nj}^2 \cdot I(w_{nj}(F) | \xi_{nj}| \leq \delta_n) \right) \leq$
 $\sup_{d_\nu^{(2)}(f,g) \leq \alpha} \sum_{j \leq j(n)} \mathbb{E} \left((f(\eta_j) - g(\eta_j))^2 \right) \cdot \mathbb{E}(\xi_{nj}^2) = \sup_{d_\nu^{(2)}(f,g) \leq \alpha} \nu((f - g)^2) \cdot \sum_{j \leq j(n)} \mathbb{E}(\xi_{nj}^2)$
 $\leq \alpha^2 \sum_{j \leq j(n)} \mathbb{E}(\xi_{nj}^2)$ which implies (7.1.5). \square

Finally, concerning function-indexed partial-sum processes with fixed locations and index set \mathcal{F} being countable, uniformly bounded and having uniformly integrable L_2 -entropy, we obtain from Theorem 7.2.8:

7.2.12 THEOREM (cf. [Zi97], 7.3).

Let $(X, \mathcal{X}) = (I^d, I^d \cap \mathcal{B}^d)$, $d \geq 1$, ($I^d \equiv [0, 1]^d$) and consider (cf. (1.4.2))

$$S_n(f) := n^{-d/2} \sum_{\underline{j} \in J_n} f(\underline{j}/n) \xi_{\underline{j}} \quad , f \in \mathcal{F},$$

($J_n := \{1, \dots, n\}^d$), where the $\xi_{\underline{j}}$, $\underline{j} \in \mathbb{N}^d$, are iid with $\mathbb{E}(\xi_{\underline{j}}) = 0$ and $\mathbb{E}(\xi_{\underline{j}}^2) = 1$. Let ν be the restriction of the d -dimensional Lebesgue measure λ^d on $I^d \cap \mathcal{B}^d$ and suppose that the following two conditions are fulfilled:

$$(7.2.13) \quad \lim_{n \rightarrow \infty} n^{-d} \sum_{\underline{j} \in J_n} \delta_{\underline{j}/n}(f \cdot g) = \lambda^d(f \cdot g) \quad \text{for all } f, g \in \mathcal{F}$$

$$(7.2.14) \quad \lim_{\alpha \rightarrow 0} \limsup_{n \rightarrow \infty} \sup_{\lambda^d((f-g)^2) \leq \alpha} n^{-d} \sum_{\underline{j} \in J_n} \delta_{\underline{j}/n}((f - g)^2) = 0.$$

Then

$$S_n \xrightarrow[\text{sep}]{\mathcal{L}} \mathbb{G}_\nu \quad \text{in } l^\infty(\mathcal{F}),$$

where $\mathbb{G}_\nu = (G_\nu(f))_{f \in \mathcal{F}}$ is a mean-zero Gaussian process with sample paths in $U^b(\mathcal{F}, d_{\lambda^d}^{(2)})$ and $\text{cov}(G_\nu(f), G_\nu(g)) = \lambda^d(f \cdot g)$ for $f, g \in \mathcal{F}$.

In the set-indexed case, i.e. for (cf. (1.4.2))

$$S_n(C) = n^{-d/2} \sum_{\underline{j} \in J_n} 1_C(\underline{j}/n) \xi_{\underline{j}} \quad , C \in \mathcal{C},$$

with $\mathcal{C} \subset I^d \cap \mathcal{B}^d$, attempts to find natural conditions under which (7.2.13) and (7.2.14) hold have been made in [Al87]; cf. also [Gae94], Remark 2.16 and the results contained in [Va96], Section 2.12.2: Partial-Sum Processes on Lattices.

7.3 FCLT's for empirical processes

Let $X = (X, \mathcal{X})$ be again an arbitrary measurable space (sample space) and $(\eta_{nj})_{1 \leq j \leq j(n), n \in \mathbb{N}}$ (with $j(n) \rightarrow \infty$ as $n \rightarrow \infty$) be a triangular array of re's in (X, \mathcal{X}) assumed to be rowwise independent (but not necessarily identically distributed) with law $\mathcal{L}\{\eta_{nj}\} = \nu_{nj}$. Let \mathcal{F} be a class of \mathcal{X} -measurable functions $f : X \rightarrow \mathbb{R}$ with \mathcal{X} -measurable envelope $F : X \rightarrow \mathbb{R}$; \mathcal{F} being countable for simplicity. Assume that \mathcal{F} has uniformly integrable L_2 -entropy and that there is some pseudo-metric d on \mathcal{F} such that (\mathcal{F}, d) is totally bounded (e.g. $d = d_\nu^{(2)}$ for some p-measure ν on \mathcal{X} with $\nu(F^2) < \infty$; cf. 4.3.21). We are going to apply our FCLT for RMP's 7.1.3 with $w_{nj} = \delta_{\eta_{nj}}$ and $\xi_{nj} = j(n)^{-1/2}$ to obtain the following

FCLT for empirical processes in the non-iid -case,

i.e. for $S_n = (S_n(f))_{f \in \mathcal{F}}$ with

$$S_n(f) := j(n)^{-1/2} \sum_{j \leq j(n)} (f(\eta_{nj}) - \nu_{nj}(f)), \quad f \in \mathcal{F}.$$

7.3.1 THEOREM (cf. [Zi97], 4.2).

Assume $S_n \xrightarrow[\text{fidi}]{\mathcal{L}} \bar{\mathbb{G}}$, where $\bar{\mathbb{G}} = (\bar{G}(f))_{f \in \mathcal{F}}$ is a mean-zero Gaussian process. Let

$$\bar{\nu}_n := j(n)^{-1} \sum_{j \leq j(n)} \nu_{nj}, \quad a_n(\alpha) := \sup_{d(f,g) \leq \alpha} \left(\bar{\nu}_n((f-g)^2) \right)^{1/2}, \quad \alpha > 0,$$

and suppose that the following conditions are fulfilled:

$$(7.3.2) \quad \sup_{n \in \mathbb{N}} \bar{\nu}_n(F^2) < \infty \quad (\text{whence } S_n \text{ has its sample paths in } l^\infty(\mathcal{F}))$$

$$(7.3.3) \quad \lim_{\alpha \rightarrow 0} \limsup_{n \rightarrow \infty} a_n(\alpha) = 0$$

$$(7.3.4) \quad \lim_{n \rightarrow \infty} j(n)^{-1} \sum_{j \leq j(n)} \mathbb{E} \left(F^2(\eta_{nj}) \cdot I(F(\eta_{nj}) > \delta j(n)^{1/2}) \right) = 0 \quad \text{for all } \delta > 0.$$

Then

$$S_n \xrightarrow[\text{sep}]{\mathcal{L}} \mathbb{G} \quad \text{in } l^\infty(\mathcal{F}),$$

where $\mathbb{G} = (G(f))_{f \in \mathcal{F}}$ is a mean-zero Gaussian process with sample paths in $U^b(\mathcal{F}, d)$ and $\mathbb{G} \stackrel{\mathcal{L}}{\text{fidi}} \bar{\mathbb{G}}$.

PROOF. The proof runs along the same pattern as the proof of Theorem 7.2.11. According to Theorem 7.1.3 we have to verify (7.1.4) – (7.1.6) (with $w_{nj} = \delta_{\eta_{nj}}$ and $\xi_{nj} = j(n)^{-1/2}$):

As to (7.1.4): $\sum_{j \leq j(n)} \mathbb{E} \left(w_{nj}(F) |\xi_{nj}| \cdot I(w_{nj}(F) |\xi_{nj}| > \delta_n) \right) = \sum_{j \leq j(n)} \mathbb{E} \left(F(\eta_{nj}) j(n)^{-1/2} \cdot I(F(\eta_{nj}) > \delta_n j(n)^{1/2}) \right) \leq \delta_n^{-1} j(n)^{-1} \sum_{j \leq j(n)} \mathbb{E} \left(F^2(\eta_{nj}) \cdot I(F(\eta_{nj}) > \delta_n j(n)^{1/2}) \right) \rightarrow 0$ with an appropriate chosen

sequence $(\delta_n)_{n \in \mathbb{N}} \subset \mathbb{R}_+$ with $\delta_n \rightarrow 0$, since by (7.3.4)

$$\delta^{-1} j(n)^{-1} \sum_{j \leq j(n)} \mathbb{E} \left(F^2(\eta_{nj}) \cdot I(F(\eta_{nj}) > \delta j(n)^{1/2}) \right) \rightarrow 0$$

as $n \rightarrow \infty$ for all $\delta > 0$.

As to (7.1.6): $\sup_{n \in \mathbb{N}} \sum_{j \leq j(n)} \mathbb{E} \left(w_{nj}(F^2) \xi_{nj}^2 \cdot I(w_{nj}(F) |\xi_{nj}| \leq \delta_n) \right) = \sup_{n \in \mathbb{N}} \sum_{j \leq j(n)} \mathbb{E}(F^2(\eta_{nj}) j(n)^{-1} \cdot I(F(\eta_{nj}) \leq \delta_n j(n)^{1/2})) \leq \sup_{n \in \mathbb{N}} j(n)^{-1} \sum_{j \leq j(n)} \mathbb{E}(F^2(\eta_{nj})) = \sup_{n \in \mathbb{N}} j(n)^{-1} \sum_{j \leq j(n)} \nu_{nj}(F^2) = \sup_{n \in \mathbb{N}} \bar{\nu}_n(F^2) < \infty$ by (7.3.2).

As to (7.1.5): $\sup_{d(f,g) \leq \alpha} \sum_{j \leq j(n)} \mathbb{E} \left((w_{nj}(f) - w_{nj}(g))^2 \xi_{nj}^2 \cdot I(w_{nj}(F) |\xi_{nj}| \leq \delta_n) \right) = \sup_{d(f,g) \leq \alpha} \sum_{j \leq j(n)} \mathbb{E} \left((f(\eta_{nj}) - g(\eta_{nj}))^2 j(n)^{-1} \cdot I(F(\eta_{nj}) \leq \delta_n j(n)^{1/2}) \right) \leq \sup_{d(f,g) \leq \alpha} j(n)^{-1} \sum_{j \leq j(n)} \mathbb{E} \left((f(\eta_{nj}) - g(\eta_{nj}))^2 \right) = \sup_{d(f,g) \leq \alpha} j(n)^{-1} \sum_{j \leq j(n)} \nu_{nj}((f-g)^2) = \sup_{d(f,g) \leq \alpha} \bar{\nu}_n((f-g)^2) = a_n^2(\alpha)$, from which (7.1.5) follows according to (7.3.3). \square

Replacing the triangular array (η_{nj}) by a sequence $(\eta_j)_{j \in \mathbb{N}}$ of iid re's in (X, \mathcal{X}) with law $\mathcal{L}\{\eta_j\} = \nu$, we obtain from Theorem 7.3.1 the following FCLT for *empirical \mathcal{F} -processes* in the iid -case, i.e. for $\beta_n = (\beta_n(f))_{f \in \mathcal{F}}$ with $\beta_n(f) := n^{-1/2} \sum_{j \leq n} (f(\eta_j) - \nu(f)) = n^{1/2}(\nu_n(f) - \nu(f))$, where $\nu_n(f) := n^{-1} \sum_{j \leq n} f(\eta_j)$ (cf. 2.2.1 in the set-indexed case):

7.3.5 THEOREM.

Suppose that \mathcal{F} has uniformly integrable L_2 -entropy and that $\nu(F^2) < \infty$ (\mathcal{F} being countable for simplicity). Then

$$\beta_n \xrightarrow[\text{sep}]{\mathcal{L}} \mathbb{G}_\nu \quad \text{in } l^\infty(\mathcal{F}),$$

where $\mathbb{G}_\nu = (G_\nu(f))_{f \in \mathcal{F}}$ is a mean-zero Gaussian process with sample paths in $U^b(\mathcal{F}, d_\nu^{(2)})$ and $\text{cov}(G_\nu(f), G_\nu(g)) = \nu(f \cdot g) - \nu(f) \cdot \nu(g)$ for $f, g \in \mathcal{F}$.

PROOF. $\beta_n \xrightarrow[\text{fidi}]{\mathcal{L}} \mathbb{G}_\nu$ follows by the classical multivariate CLT. The conditions (7.3.2) and (7.3.3) are obviously fulfilled. As to (7.3.4) we have in the present case

$$\lim_{n \rightarrow \infty} n^{-1} \sum_{j \leq n} \mathbb{E} \left(F^2(\eta_j) \cdot I(F(\eta_j) > \delta n^{1/2}) \right) = \lim_{n \rightarrow \infty} \mathbb{E} \left(F^2(\eta_1) \cdot I(F(\eta_1) > \delta n^{1/2}) \right) = 0,$$

since $\mathbb{E}(F^2(\eta_1)) = \nu(F^2) < \infty$. Thus Theorem 7.3.1 yields the assertion. \square

7.3.6 REMARK.

Concerning VCGC's \mathcal{F} (having uniformly integrable L_2 -entropy according to 4.3.21) with $\nu(F^2) < \infty$, the assertion of Theorem 7.3.5 holds true, especially for $\mathcal{F} = \{1_C : C \in \mathcal{C}\}, \mathcal{C} \subset \mathcal{X}$ being a countable VCC; see Theorem 2.2.1.

7.4 FCLT's for smoothed empirical processes

Throughout this section X is supposed to be an arbitrary *linear metric space* endowed with its Borel σ -field \mathcal{X} . The basic situation is the same as in section 6.4, i.e. given iid re's $\eta_j, j \in \mathbb{N}$, in (X, \mathcal{X}) with law $\mathcal{L}\{\eta_j\} = \nu$ on \mathcal{X} we consider the smoothed empirical measures

$$\tilde{\nu}_n := \nu_n \star \mu_n, \quad n \in \mathbb{N},$$

indexed by classes \mathcal{F} of \mathcal{X} -measurable functions $f : X \rightarrow \mathbb{R}$ with \mathcal{X} -measurable envelope $F : X \rightarrow \mathbb{R}$ assuming that $\nu(F^2) := \int_X F^2 d\nu < \infty$. Remember from 6.4 that

$$(7.4.1) \quad \begin{aligned} \tilde{\nu}_n(f) &= \int_X \int_X f(x+y) \nu_n(dx) \mu_n(dy) = n^{-1} \sum_{j \leq n} \int_X f(\eta_j + y) \mu_n(dy) \\ \text{and} \quad \mathbb{E}(\tilde{\nu}_n(f)) &= \nu \star \mu_n(f) \quad \forall f \in \mathcal{F} \text{ (cf. (6.4.3) and (6.4.4)).} \end{aligned}$$

Also our decomposition from 6.4 will be again important, i.e.

$$(7.4.2) \quad \tilde{\nu}_n - \nu = \tilde{\nu}_n - \nu \star \mu_n + \nu \star \mu_n - \nu,$$

noticing that $\tilde{\nu}_n - \nu \star \mu_n = \tilde{\nu}_n - \mathbb{E}(\tilde{\nu}_n)$ is a mean-zero RMP and where $\nu \star \mu_n - \nu$ is the *non-stochastic* bias term.

As in 6.4 let $\tilde{\mathcal{F}}$ be the class of all translates f_x of elements f of \mathcal{F} (with $f_x(y) := f(x+y), y \in X$). Without imposing the condition $\mathcal{F} = \tilde{\mathcal{F}}$ we are going to apply our FCLT for RMP's 7.1.3 with (cf. (7.4.1))

$$w_{nj}(f) := \int_X f(\eta_j + y) \mu_n(dy), \quad \text{and} \quad \xi_{nj} := n^{-1/2}, 1 \leq j \leq j(n) := n, n \in \mathbb{N},$$

to obtain sufficient conditions under which

$$(7.4.3) \quad \left(\sqrt{n}(\tilde{\nu}_n(f) - \nu(f)) \right)_{f \in \mathcal{F}} \xrightarrow[\text{sep}]{\mathcal{L}} \mathbb{G} \quad \text{in } l^\infty(\mathcal{F}),$$

where $\mathbb{G} = (G(f))_{f \in \mathcal{F}}$ is a mean-zero Gaussian process with sample paths in $U^b(\mathcal{F}, d_\nu^{(2)})$.

Remember that $U^b(\mathcal{F}, d_\nu^{(2)})$ is a separable subspace of $(l^\infty(\mathcal{F}), \|\cdot\|_{\mathcal{F}})$ if and only if $(\mathcal{F}, d_\nu^{(2)})$ is totally bounded ([Gae90], Corollary 2) where the latter is true for classes \mathcal{F} having uniformly integrable L_2 -entropy (cf. 4.3.21).

Now, in view of (7.4.2), Theorem 7.1.3 yields immediately the following FCLT. (Note that the η_j 's on which the w_{nj} 's are based are iid.)

7.4.4 THEOREM (cf. [Ro97], Theorem 3.2.2).

Let X be a linear metric space and let \mathcal{F} have uniformly integrable L_2 -entropy. Assume that the following conditions (7.4.5) – (7.4.8) are fulfilled:

For each $\rho > 0$ there exists $\delta_n \equiv \delta_n(\rho)$, $n \in \mathbb{N}$, $\delta_n \rightarrow 0$ such that

$$(7.4.5) \quad \limsup_{n \rightarrow \infty} \sqrt{n} \cdot \mathbb{E} \left(w_{n1}(F) I(w_{n1}(F) > \delta_n \sqrt{n}) \right) \leq \rho$$

$$(7.4.6) \quad \lim_{\alpha \rightarrow 0} \limsup_{n \rightarrow \infty} \sup_{d_\nu^{(2)}(f, g) \leq \alpha} \mathbb{E} \left((w_{n1}(f) - w_{n1}(g))^2 \cdot I(w_{n1}(F) \leq \delta_n \sqrt{n}) \right) = 0$$

$$(7.4.7) \quad \sup_{n \in \mathbb{N}} \mathbb{E} \left(w_{n1}(F^2) \cdot I(w_{nj}(F) \leq \delta_n \sqrt{n}) \right) < \infty$$

$$(7.4.8) \quad \sup_{f \in \mathcal{F}} \sqrt{n} |\nu \star \mu_n(f) - \nu(f)| \rightarrow 0.$$

Assume, in addition, that there exists a mean-zero Gaussian process $\bar{\mathbb{G}} = (\bar{\mathbb{G}}(f))_{f \in \mathcal{F}}$ such that $\sqrt{n}(\tilde{\nu}_n - \nu \star \mu_n) \xrightarrow[\text{fidi}]{\mathcal{L}} \bar{\mathbb{G}}$.

Then there exists a mean-zero Gaussian process $\mathbb{G} = (\mathbb{G}(f))_{f \in \mathcal{F}}$ with sample paths in $U^b(\mathcal{F}, d_\nu^{(2)})$ such that

$$\sqrt{n}(\tilde{\nu}_n - \nu) \xrightarrow[\text{sep}]{\mathcal{L}} \mathbb{G} \quad \text{in } l^\infty(\mathcal{F}) \text{ and } \mathbb{G} \xrightarrow[\text{fidi}]{\mathcal{L}} \bar{\mathbb{G}}.$$

Before going further, let us have a view on a FCLT for smoothed empirical processes under the condition $\mathcal{F} = \tilde{\mathcal{F}}$:

From van der Vaart [Va94] one gets the following result. For this, \mathcal{F} is called a ν -Donsker class if (cf. Theorem 7.3.5) $\left(\sqrt{n}(\nu_n(f) - \nu(f)) \right)_{f \in \mathcal{F}} \xrightarrow[\text{sep}]{\mathcal{L}} \mathbb{G}_\nu$ in $l^\infty(\mathcal{F})$.

7.4.9 THEOREM.

Let $X = \mathbb{R}^d$, $d \geq 1$, and assume $\mathcal{F} = \tilde{\mathcal{F}}$. Let \mathcal{F} be ν -Donsker and μ_n p -measures on \mathcal{B}^d with $\mu_n \rightarrow \delta_0$ weakly. Suppose that the following two conditions are fulfilled:

$$(7.4.10) \quad \sup_{f \in \mathcal{F}} \int_X \left[\int_X (f(x+y) - f(x)) \mu_n(dy) \right]^2 \nu(dx) \rightarrow 0$$

$$(7.4.11) \quad \sup_{f \in \mathcal{F}} \sqrt{n} |\nu \star \mu_n(f) - \nu(f)| \rightarrow 0$$

Then

$$\sqrt{n}(\tilde{\nu}_n - \nu) \xrightarrow[\text{sep}]{\mathcal{L}} \mathbb{G} \quad \text{in } l^\infty(\mathcal{F}),$$

where $\mathbb{G} = (\mathbb{G}(f))_{f \in \mathcal{F}}$ is a mean-zero Gaussian process with sample paths in $U^b(\mathcal{F}, d_\nu^{(2)})$.

NOTE: In [Va94] the μ_n 's are even allowed to be *random* p -measures on \mathcal{B}^d . On the other hand it should be noted that \mathcal{F} being a ν -Donsker class does in general not imply that $\tilde{\mathcal{F}}$ is also a ν -Donsker class (cf. Example 2.2.8 in [Ro97]) as it is imposed in 7.4.9 via the $\mathcal{F} = \tilde{\mathcal{F}}$ - assumption. See also [Ro99] for a comparison with a result of Yukich [Yu92] obtained in the case $X = \mathbb{R}^d$, $d \geq 1$, $\mathcal{F} = \tilde{\mathcal{F}}$, \mathcal{F} a ν -Donsker class. The method of proof in [Va94] and [Yu92], respectively, is completely different

from our approach via RMP's (see [Ro99] for a discussion). Their key method consists of showing asymptotic (stochastic) equivalence of the empirical process $\sqrt{n}(\nu_n - \nu)$ and the unbiased smoothed empirical processes $\sqrt{n}(\tilde{\nu}_n - \nu \star \mu_n)$ in order to apply the Cramér-Slutsky-type result (cf. Theorem 2.3.15).

Now, in view of Theorem 7.4.9 we will present in the following more tractable conditions compared with those in Theorem 7.4.4, but again without imposing the condition $\mathcal{F} = \tilde{\mathcal{F}}$:

7.4.12 THEOREM (cf. [Ro97], Theorem 3.2.3).

Let X be a linear metric space and \mathcal{F} have uniformly integrable L_2 -entropy. Assume that the following conditions (7.4.13) and (7.4.14) are fulfilled:

$$(7.4.13) \quad \sup_{f \in \mathcal{F}} \int_X \left[\int_X (f(x+y) - f(x)) \mu_n(dy) \right]^2 \nu(dx) \longrightarrow 0$$

$$(7.4.14) \quad \sup_{f \in \mathcal{F} \cup \{F^3\}} \sqrt{n} |\nu \star \mu_n(f) - \nu(f)| \longrightarrow 0.$$

Then

$$\sqrt{n}(\tilde{\nu}_n - \nu) \xrightarrow[\text{sep}]{\mathcal{L}} \mathbb{G}_\nu \quad \text{in } l^\infty(\mathcal{F}),$$

where $\mathbb{G}_\nu = (\mathbb{G}_\nu(f))_{f \in \mathcal{F}}$ is a mean-zero Gaussian process with sample paths in $U^b(\mathcal{F}, d_\nu^{(2)})$ and $\text{cov}(G_\nu(f), G_\nu(g)) = \nu(f \cdot g) - \nu(f) \cdot \nu(g)$ for $f, g \in \mathcal{F}$.

PROOF. To prove this result, one shows (7.4.5) – (7.4.7), fidi-convergence and then one applies Theorem 7.4.4. This is carried out in [Ro99].

NOTE: Condition (7.4.13) is just (7.4.10), whereas (7.4.14) is apparently a bit stronger than (7.4.11) implying convergence also for F^3 . In (7.4.14) it is tacitly understood that $\nu \star \mu_n(F^3)$ and $\nu(F^3)$ exist. (7.4.14) can be replaced by (7.4.11) if, in addition, $\nu \star \mu_n(F^{2+\varepsilon}) \longrightarrow \nu(F^{2+\varepsilon})$ for some $\varepsilon > 0$. On the other hand, as already mentioned in section 6.4, the condition $\mathcal{F} = \tilde{\mathcal{F}}$ implies that \mathcal{F} is uniformly bounded. But for uniformly bounded \mathcal{F} (7.4.14) reduces to (7.4.11), and so we get finally the following result:

7.4.15 THEOREM (cf. [Ro97], Theorem 3.2.4).

Let X be a linear metric space and let \mathcal{F} be uniformly bounded having uniformly integrable L_2 -entropy. Assume that the conditions (7.4.8) and (7.4.13) are satisfied. Then

$$\sqrt{n}(\tilde{\nu}_n - \nu) \xrightarrow[\text{sep}]{\mathcal{L}} \mathbb{G}_\nu \quad \text{in } l^\infty(\mathcal{F}),$$

where $\mathbb{G}_\nu = (\mathbb{G}_\nu(f))_{f \in \mathcal{F}}$ is a mean-zero Gaussian process with sample paths in $U^b(\mathcal{F}, d_\nu^{(2)})$ and $\text{cov}(G_\nu(f), G_\nu(g)) = \nu(f \cdot g) - \nu(f) \cdot \nu(g)$ for $f, g \in \mathcal{F}$.

7.5 A uniform FCLT for the unbiased smoothed empirical process

As in section 7.4 X is supposed to be an arbitrary *linear metric space* endowed with its Borel σ -field \mathcal{X} and $\eta_j, j \in \mathbb{N}$, are i.i.d. re's in (X, \mathcal{X}) with law $\mathcal{L}\{\eta_j\} = \nu$ on \mathcal{X} .

Let us consider first the non-smoothed empirical process $\mathbb{G}_n^\nu := \sqrt{n}(\nu_n - \nu)$ indexed by a (countable, for simplicity) class \mathcal{F} of \mathcal{X} -measurable functions $f : X \rightarrow \mathbb{R}$ with \mathcal{X} -measurable envelope $F : X \rightarrow \mathbb{R}$ such that $\nu(F^2) < \infty$.

As we know from (7.1.2) and the general comments preceding (7.1.2) we have

$$\mathbb{G}_n^\nu \xrightarrow[\text{sep}]{\mathcal{L}} \mathbb{G}_\nu \quad \text{in } l^\infty(\mathcal{F}) \iff d_{BL}(\mathbb{G}_n^\nu, \mathbb{G}_\nu) \rightarrow 0,$$

where $\mathbb{G}_\nu = (G_\nu(g))_{g \in \mathcal{F}}$ is a mean-zero Gaussian process with sample paths in $U^b(\mathcal{F}, d_\nu^{(2)})$ and

$$\text{cov}(G_\nu(f), G_\nu(g)) = \nu(f \cdot g) - \nu(f) \cdot \nu(g) \quad \text{for } f, g \in \mathcal{F},$$

calling (as in section 7.4) \mathcal{F} to be a ν -Donsker class in this case.

Now, concerning the question whether \mathcal{F} is also a *uniform Donsker class*, i.e. whether $\sup_{\nu \in \mathcal{M}^1(X)} d_{BL}(\mathbb{G}_n^\nu, \mathbb{G}_\nu) \rightarrow 0$ (and $(\mathcal{F}, d_\nu^{(2)})$ is totally bounded uniformly in ν), where $\mathcal{M}^1(X)$ denotes the class of all ν -measures on \mathcal{X} , the following result is known (see [Gi97], Theorem 5.3 and [Gi91]):

7.5.1 THEOREM.

Let X be an arbitrary measurable space and \mathcal{F} be uniformly bounded having uniformly integrable L_2 -entropy. Then (with $\mathcal{L}\{\mathbb{G}_\nu\}$ being tight)

$$(7.5.2) \quad \sup_{\nu \in \mathcal{M}^1(X)} d_{BL}(\mathbb{G}_n^\nu, \mathbb{G}_\nu) \rightarrow 0.$$

Uniform Donsker classes were e.g. studied by Sheehy and Wellner [She92] (who also studied in detail (7.5.2) with the supremum taken over subclasses of $\mathcal{M}^1(X)$) and by Giné and Zinn [Gi91]. They showed that (putting measurability questions aside) a so-called *uniformly pregaussian class* \mathcal{F} (saying \mathcal{F} is UPG) is a uniform Donsker class.

\mathcal{F} is UPG means that the following two conditions are fulfilled:

$$(7.5.3) \quad \sup_{\nu \in \mathcal{M}^1(X)} \mathbb{E}(\|\mathbb{Z}_\nu\|_{\mathcal{F}}) < \infty$$

$$(7.5.4) \quad \lim_{\delta \rightarrow 0} \sup_{\nu \in \mathcal{M}^1(X)} \mathbb{E}\left(\sup\{|Z_\nu(f) - Z_\nu(g)| : f, g \in \mathcal{F}, d_\nu^{(2)}(f, g) \leq \delta\}\right) = 0.$$

In both conditions \mathbb{Z}_ν can be replaced by \mathbb{G}_ν (see [Gi97], Theorem 5.3).

Here $\mathbb{Z}_\nu = (Z_\nu(f))_{f \in \mathcal{F}}$ stands for a mean-zero Gaussian process with tight law $\mathcal{L}\{\mathbb{Z}_\nu\}$ on $\mathcal{B}(l^\infty(\mathcal{F}))$ whose covariance structure is given by

$$\text{cov}(Z_\nu(f), Z_\nu(g)) = \nu(f \cdot g) \quad \text{for } f, g \in \mathcal{F}.$$

From [Va96], Example 1.5.10 it follows that also \mathbb{Z}_ν (as \mathbb{G}_ν) can be chosen to have its sample paths in $U^b(\mathcal{F}, d_\nu^{(2)})$; note that $d_\nu^{(2)}$ coincides with the so-called *intrinsic pseudo-metric* $\rho_{\mathbb{Z}_\nu}$ (on \mathcal{F}) for \mathbb{Z}_ν , i.e.

$$\rho_{\mathbb{Z}_\nu}(f, g) := \mathbb{E}^{1/2}(|Z_\nu(f) - Z_\nu(g)|^2) = d_\nu^{(2)}(f, g) \quad \text{for } f, g \in \mathcal{F}.$$

Now we are going to establish an analogous result as (7.5.2) for smoothed empirical processes under conditions similar to (7.5.3) and (7.5.4) replacing \mathbb{G}_n^ν by the unbiased smoothed empirical process

$$\tilde{\mathbb{G}}_n^\nu := (\tilde{G}_n^\nu(f))_{f \in \mathcal{F}},$$

where $\tilde{G}_n^\nu(f) := \sqrt{n}(\tilde{\nu}_n(f) - \nu \star \mu_n(f))$, $f \in \mathcal{F}$.

7.5.5 THEOREM (cf. [Ro97], Theorem 4.4).

Let X be a linear metric space and \mathcal{F} be uniformly bounded. Suppose that for every $\nu \in \mathcal{M}^1(X)$ there is a mean-zero Gaussian process $\mathbb{G}_\nu = (G_\nu(h))_{h \in \mathcal{F} \cup \mathcal{G}}$ with tight law $\mathcal{L}\{\mathbb{G}_\nu\}$ on $\mathcal{B}(l^\infty(\mathcal{F} \cup \mathcal{G}))$ where

$$\mathcal{G} := \{g_{f, \mu_n} : f \in \mathcal{F}, n \in \mathbb{N}\} \quad \text{with} \quad g_{f, \mu_n}(x) := \int_X f(x+y) \mu_n(dy), x \in X.$$

Assume that the following conditions (7.5.6) – (7.5.8) are fulfilled:

$$(7.5.6) \quad \sup_{\nu \in \mathcal{M}^1(X)} \mathbb{E}(\|\mathbb{G}_\nu\|_{\mathcal{F}}) < \infty$$

$$(7.5.7) \quad \lim_{\delta \rightarrow 0} \sup_{\nu \in \mathcal{M}^1(X)} \mathbb{E}\left(\sup\{|G_\nu(h_1) - G_\nu(h_2)| : h_1, h_2 \in \mathcal{F} \cup \mathcal{G}, d_\nu^{(2)}(h_1, h_2) \leq \delta\}\right) = 0$$

$$(7.5.8) \quad \sup_{\nu \in \mathcal{M}^1(X)} \sup_{f \in \mathcal{F}} \int_X \left[\int_X (f(x+y) - f(x)) \mu_n(dy) \right]^2 \nu(dx) \longrightarrow 0.$$

Then

$$(7.5.9) \quad \sup_{\nu \in \mathcal{M}^1(X)} d_{BL}(\tilde{\mathbb{G}}_n^\nu, \mathbb{G}_\nu) \longrightarrow 0.$$

In (7.5.9) not only $\tilde{\mathbb{G}}_n^\nu$ but also \mathbb{G}_ν (restricted to the index set \mathcal{F}) is considered as a process with sample paths in $l^\infty(\mathcal{F})$ whose law $\mathcal{L}\{\mathbb{G}_\nu\}$ is tight on $\mathcal{B}(l^\infty(\mathcal{F}))$; so d_{BL} in (7.5.9) stands for the bounded Lipschitz distance based on $l^\infty(\mathcal{F})$ (and not on $l^\infty(\mathcal{F} \cup \mathcal{G})$).

PROOF. We follow the lines of proof of (7.5.2) as given in [Gi97], respectively the lines of proof of Theorem 2.3 in [Gi91] under the conditions (7.5.3) and (7.5.4) using Gaussian comparison methods.

First, we show that for each $\tau > 0$

$$(7.5.10) \quad \sup_{\nu \in \mathcal{M}^1(X)} N(\tau, \mathcal{F}, d_\nu^{(2)}) < \infty.$$

As to (7.5.10), according to Sudakov's Inequality (cf. [Va96], A.2.5) there exists a constant $0 < K < \infty$ such that for every $\nu \in \mathcal{M}^1(X)$

$$\left(\log N(\tau, \mathcal{F}, \rho_{\mathbb{Z}\nu}) \right)^{1/2} \leq K \cdot \mathbb{E}(\|\mathbb{Z}_\nu\|_{\mathcal{F}})$$

(with $\rho_{\mathbb{Z}_\nu}(f, g) := \mathbb{E}^{1/2}(|Z_\nu(f) - Z_\nu(g)|^2) = d_\nu^{(2)}(f, g) \quad \forall f, g \in \mathcal{F}$)

whence

$$\left(\log N(\tau, \mathcal{F}, d_\nu^{(2)})\right)^{1/2} \leq K \cdot \mathbb{E}(\|\mathbb{Z}_\nu\|_{\mathcal{F}}).$$

Now, let g be a standard normal distributed rv which is independent of \mathbb{G}_ν ; then

$$\mathcal{L}\{\mathbb{G}_\nu + g \cdot \nu\} = \mathcal{L}\{\mathbb{Z}_\nu\}$$

(as can be seen by computing covariances), so

$$\mathbb{E}(\|\mathbb{Z}_\nu\|_{\mathcal{F}}) \leq \mathbb{E}(\|\mathbb{G}_\nu\|_{\mathcal{F}}) + \mathbb{E}(|g|) \cdot \sup_{f \in \mathcal{F}} |\nu(f)|,$$

whence (7.5.6) together with \mathcal{F} being uniformly bounded yields (7.5.10).

Next, let $k := \sup_{\nu \in \mathcal{M}^1(X)} N(\tau, \mathcal{F}, d_\nu^{(2)})$, and for each $\nu \in \mathcal{M}^1(X)$ let $f_1, \dots, f_k \in \mathcal{F}$ denote the centers of the $d_\nu^{(2)}$ -balls with radius τ that cover \mathcal{F} . (Note that, of course, f_1, \dots, f_k depend on ν .) Then for each $f \in \mathcal{F}$ let $\pi_\tau(f) \in \{f_1, \dots, f_k\}$ be such that

$$d_\nu^{(2)}(\pi_\tau(f), f) \leq \tau \quad (\text{where w.l.o.g. } \pi_\tau(f_i) = f_i \quad \forall i = 1, \dots, k).$$

This allows us to define the following processes $\tilde{\mathbb{G}}_n^\nu(\pi_\tau) = (\tilde{G}_n^\nu(\pi_\tau)(f))_{f \in \mathcal{F}}$ and $\mathbb{G}_\nu(\pi_\tau) = (G_\nu(\pi_\tau)(f))_{f \in \mathcal{F}}$ with sample paths in $l^\infty(\mathcal{F})$ by

$$\begin{aligned} \tilde{G}_n^\nu(\pi_\tau)(f) &:= \tilde{G}_n^\nu(\pi_\tau(f)) \\ \text{and } G_\nu(\pi_\tau)(f) &:= G_\nu(\pi_\tau(f)) \quad , f \in \mathcal{F}. \end{aligned}$$

Then, for each $H \in BL_1(l^\infty(\mathcal{F}))$ we have the decomposition

$$\begin{aligned} |\mathbb{E}^*(H(\tilde{\mathbb{G}}_n^\nu)) - \mathbb{E}(H(\mathbb{G}_\nu))| &\leq |\mathbb{E}^*(H(\tilde{\mathbb{G}}_n^\nu)) - \mathbb{E}(H(\tilde{\mathbb{G}}_n^\nu(\pi_\tau)))| \\ &\quad + |\mathbb{E}(H(\tilde{\mathbb{G}}_n^\nu(\pi_\tau))) - \mathbb{E}(H(\mathbb{G}_\nu(\pi_\tau)))| \\ &\quad + |\mathbb{E}(H(\mathbb{G}_\nu(\pi_\tau))) - \mathbb{E}(H(\mathbb{G}_\nu))| \\ &=: I_{1n} + I_{2n} + I_{3n}. \end{aligned}$$

We will show

$$(7.5.11) \quad \limsup_{\tau \rightarrow 0} \limsup_{n \rightarrow \infty} \sup_{\nu \in \mathcal{M}^1(X)} \sup_{H \in BL_1(l^\infty(\mathcal{F}))} I_{in} = 0 \quad \text{for } i = 1, 2, 3.$$

As to I_{3n} : Since $H \in BL_1(l^\infty(\mathcal{F}))$ we have

$$\begin{aligned} &|\mathbb{E}(H(\mathbb{G}_\nu(\pi_\tau))) - \mathbb{E}(H(\mathbb{G}_\nu))| \\ &\leq \mathbb{E}(\|\mathbb{G}_\nu(\pi_\tau) - \mathbb{G}_\nu\|_{\mathcal{F}}) \leq \mathbb{E}(\sup\{|\mathbb{G}_\nu(f) - \mathbb{G}_\nu(g)| : f, g \in \mathcal{F}, d_\nu^{(2)}(f, g) \leq \tau\}), \end{aligned}$$

so (7.5.7) yields (7.5.11) for $i = 3$.

As to I_{2n} : Let $\nu \in \mathcal{M}^1(X)$ and $H \in BL_1(l^\infty(\mathcal{F}))$ be arbitrary. Then there exists a bounded Lipschitz function $L : \mathbb{R}^k \rightarrow \mathbb{R}$ s.t.

$$H(x(\pi_\tau)) = L((x(f_1), \dots, x(f_k))) \quad \forall x \in l^\infty(\mathcal{F})$$

with $x(\pi_\tau)(f) := x(\pi_\tau(f))$, $f \in \mathcal{F}$. So we obtain

$$\begin{aligned} & |\mathbb{E}(H(\tilde{\mathbb{G}}_n^\nu(\pi_\tau))) - \mathbb{E}(H(\mathbb{G}_\nu(\pi_\tau)))| \\ & \leq d_{BL}((\tilde{\mathbb{G}}_n^\nu(f_1), \dots, \tilde{\mathbb{G}}_n^\nu(f_k))^t, (\mathbb{G}_\nu(f_1), \dots, \mathbb{G}_\nu(f_k))^t), \end{aligned}$$

where the superscript t denotes the transposed vector and here d_{BL} is the bounded Lipschitz metric on the space of all p-measures (laws) on \mathcal{B}^k in \mathbb{R}^k .

Now $(\tilde{\mathbb{G}}_n^\nu(f_1), \dots, \tilde{\mathbb{G}}_n^\nu(f_k))^t = \sqrt{n} n^{-1} \sum_{j \leq n} \zeta_{nj}$ with

$$\zeta_{nj} = \begin{pmatrix} \int_X f_1(\eta_j + y) \mu_n(dy) - \nu \star \mu_n(f_1) \\ \vdots \\ \int_X f_k(\eta_j + y) \mu_n(dy) - \nu \star \mu_n(f_k) \end{pmatrix}, \quad j = 1, \dots, n, n \in \mathbb{N}.$$

Let $\mathbb{V}_{n1} = (\mathbb{V}_{n1}(i, l))_{1 \leq i, j \leq k}$ and $\Sigma_k = (\Sigma_k(i, l))_{1 \leq i, j \leq k}$ denote the covariance matrix of ζ_{nj} and $(\mathbb{G}_\nu(f_1), \dots, \mathbb{G}_\nu(f_k))^t$, respectively, where

$$\Sigma_k(i, l) = \nu(f_i \cdot f_l) - \nu(f_i) \cdot \nu(f_l) \quad , 1 \leq i, l \leq k.$$

According to the triangle inequality

$$\begin{aligned} & d_{BL}((\tilde{\mathbb{G}}_n^\nu(f_1), \dots, \tilde{\mathbb{G}}_n^\nu(f_k))^t, (\mathbb{G}_\nu(f_1), \dots, \mathbb{G}_\nu(f_k))^t) \\ & \leq d_{BL}((\tilde{\mathbb{G}}_n^\nu(f_1), \dots, \tilde{\mathbb{G}}_n^\nu(f_k))^t, \mathcal{N}_k(0, \mathbb{V}_{n1})) + d_{BL}(\mathcal{N}_k(0, \mathbb{V}_{n1}), \mathcal{N}_k(0, \Sigma_k)). \end{aligned}$$

Note that $\mathcal{L}\{(\mathbb{G}_\nu(f_1), \dots, \mathbb{G}_\nu(f_k))^t\} = \mathcal{N}_k(0, \Sigma_k)$.

Now the components $\int_X f_i(\eta_j + y) \mu_n(dy)$, $i = 1, \dots, k$, of ζ_{nj} are rv's which are bounded by 1 (since \mathcal{F} is assumed to be uniformly bounded with envelope $F \equiv 1$ w.l.o.g.) for any $f_i \in \mathcal{F}$, so this bound does not depend on ν . An application of Lemma 2.1 in [Gi91] now gives

$$\lim_{n \rightarrow \infty} \sup_{\nu \in \mathcal{M}^1(X)} d_{BL}((\tilde{\mathbb{G}}_n^\nu(f_1), \dots, \tilde{\mathbb{G}}_n^\nu(f_k))^t, \mathcal{N}_k(0, \mathbb{V}_{n1})) = 0.$$

From Lemma 2.2 in [Gi91] we have

$$d_{BL}(\mathcal{N}_k(0, \mathbb{V}_{n1}), \mathcal{N}_k(0, \Sigma_k)) \leq C \cdot \sup_{1 \leq i, l \leq k} |\mathbb{V}_{n1}(i, l) - \Sigma_k(i, l)|$$

with a constant C depending only on k .

Keeping in mind that the f_1, \dots, f_k (and therefore also \mathbb{V}_{n1} and Σ_k) depend on ν we are going to show that

$$(7.5.12) \quad \sup_{\nu \in \mathcal{M}^1(X)} \sup_{1 \leq i, l \leq k} |\mathbb{V}_{n1}(i, l) - \Sigma_k(i, l)| \rightarrow 0,$$

whence $\limsup_{n \rightarrow \infty} \sup_{\nu \in \mathcal{M}^1(X)} d_{BL}(\mathcal{N}_k(0, \mathbb{V}_{n1}), \mathcal{N}_k(0, \Sigma_k)) = 0$, which completes the proof of (7.5.11) for $i = 2$.

As to (7.5.12):

$$\mathbb{V}_{n1}(i, l) = \int_X \left[\int_X f_i(x+y) \mu_n(dy) - \nu \star \mu_n(f_i) \right] \cdot \left[\int_X f_l(x+y) \mu_n(dy) - \nu \star \mu_n(f_l) \right] \nu(dx)$$

which is equal to (inserting $f_i(x)$ and $f_l(x)$, respectively)

$$\begin{aligned} & \int_X \left[\int_X f_i(x+y) \mu_n(dy) - f_i(x) \right] \cdot \left[\int_X f_l(x+y) \mu_n(dy) - f_l(x) \right] \nu(dx) \\ & + \int_X [f_i(x) - \nu \star \mu_n(f_i)] \cdot \left[\int_X f_l(x+y) \mu_n(dy) - f_l(x) \right] \nu(dx) \\ & + \int_X [f_l(x) - \nu \star \mu_n(f_l)] \cdot \left[\int_X f_i(x+y) \mu_n(dy) - f_i(x) \right] \nu(dx) \\ & + \int_X [f_i(x) - \nu \star \mu_n(f_i)] \cdot [f_l(x) - \nu \star \mu_n(f_l)] \nu(dx) \\ & =: I_{n1}(f_i, f_l) + I_{n2}(f_i, f_l) + I_{n3}(f_i, f_l) + I_{n4}(f_i, f_l). \end{aligned}$$

The Cauchy-Schwarz inequality together with (7.5.8) yields

$$\sup_{\nu \in \mathcal{M}^1(X)} \sup_{1 \leq i, l \leq k} I_{n1}(f_i, f_l) \longrightarrow 0.$$

Next,

$$\begin{aligned} & |I_{n4}(f_i, f_l) - \Sigma_k(i, l)| = |I_{n4}(f_i, f_l) - (\nu(f_i \cdot f_l) - \nu(f_i) \cdot \nu(f_l))| \\ & = |\nu \star \mu_n(f_i) - \nu(f_i)| \cdot |\nu \star \mu_n(f_l) - \nu(f_l)| \\ & \leq \sup_{f \in \mathcal{F}} \left| \int_X \int_X (f(x+y) - f(x)) \mu_n(dy) \nu(dx) \right|^2 \leq \sup_{f \in \mathcal{F}} \int_X \left[\int_X (f(x+y) - f(x)) \mu_n(dy) \right]^2 \nu(dx), \end{aligned}$$

whence by (7.5.8)

$$\sup_{\nu \in \mathcal{M}^1(X)} \sup_{1 \leq i, l \leq k} |I_{n4}(f_i, f_l) - \Sigma_k(i, l)| \longrightarrow 0.$$

From this, the Cauchy-Schwarz Inequality and (7.5.8) again, we also have

$$\sup_{\nu \in \mathcal{M}^1(X)} \sup_{1 \leq i, l \leq k} I_{nj}(f_i, f_l) \longrightarrow 0 \quad \text{for } j = 2, 3.$$

This proves (7.5.12).

As to I_{1n} ($:= |\mathbb{E}^*(H(\tilde{\mathbb{G}}_n^\nu)) - \mathbb{E}(H(\tilde{\mathbb{G}}_n^\nu(\pi_\tau)))|$):

Since $H \in BL_1(l^\infty(\mathcal{F}))$ it suffices to show that

$$\lim_{\tau \rightarrow 0} \limsup_{n \rightarrow \infty} \sup_{\nu \in \mathcal{M}^1(X)} \mathbb{P}(\sup\{|\tilde{\mathbb{G}}_n^\nu(f_1) - \tilde{\mathbb{G}}_n^\nu(f_2)| : f_1, f_2 \in \mathcal{F}, d_\nu^{(2)}(f_1, f_2) \leq \tau\} > \delta) = 0$$

for all $\delta > 0$.

Since for each $f \in \mathcal{F}$

$$\tilde{\mathbb{G}}_n^\nu(f) = \mathbb{G}_n^\nu(g_{f, \mu_n}) \quad (\text{with } g_{f, \mu_n}(x) := \int_X f(x+y) \mu_n(dy) \quad , x \in X)$$

we have

$$\begin{aligned} & \sup\{|\tilde{\mathbb{G}}_n^\nu(f_1) - \tilde{\mathbb{G}}_n^\nu(f_2)| : f_1, f_2 \in \mathcal{F}, d_\nu^{(2)}(f_1, f_2) \leq \tau\} \\ &= \sup\{|\mathbb{G}_n^\nu(g_{f_1, \mu_n}) - \mathbb{G}_n^\nu(g_{f_2, \mu_n})| : f_1, f_2 \in \mathcal{F}, d_\nu^{(2)}(f_1, f_2) \leq \tau\} \\ (7.5.13) \leq & \sup\{|\mathbb{G}_n^\nu(f_1) - \mathbb{G}_n^\nu(f_2)| : f_1, f_2 \in \mathcal{F}, d_\nu^{(2)}(f_1, f_2) \leq \tau\} + 2 \cdot \sup_{f \in \mathcal{F}} |\mathbb{G}_n^\nu(f) - \mathbb{G}_n^\nu(g_{f, \mu_n})|. \end{aligned}$$

We show first

$$(a) \quad \limsup_{n \rightarrow \infty} \sup_{\nu \in \mathcal{M}^1(X)} \mathbb{P}(\sup_{f \in \mathcal{F}} |\mathbb{G}_n^\nu(f) - \mathbb{G}_n^\nu(g_{f, \mu_n})| > \delta) = 0 \quad \forall \delta > 0.$$

Let $\delta > 0$ be arbitrary but fixed. Then by Markov's inequality and the Symmetrization Inequality 5.1.2 we obtain

$$\begin{aligned} & \mathbb{P}(\sup_{f \in \mathcal{F}} |\mathbb{G}_n^\nu(f) - \mathbb{G}_n^\nu(g_{f, \mu_n})| > \delta) \\ & \leq \delta^{-1} \sqrt{n} \mathbb{E}(\sup_{f \in \mathcal{F}} |\nu_n(f - g_{f, \mu_n}) - \nu(f - g_{f, \mu_n})|) \\ & \leq 2 \delta^{-1} \sqrt{n} \mathbb{E}(\sup_{f \in \mathcal{F}} |n^{-1} \sum_{j \leq n} \varepsilon_j (f - g_{f, \mu_n})(\eta_j)|), \end{aligned}$$

where $\varepsilon_1, \varepsilon_2, \dots$ is a canonically formed Rademacher sequence which is independent of $(\eta_j)_{j \in \mathbb{N}}$.

Now, by Lemma 2.9.1 in [Va96] we can replace the ε_j 's by a sequence of iid rv's g_j with $\mathcal{L}\{g_j\} = \mathcal{N}(0, 1)$, to obtain the following upper bound (by taking expectations w.r.t. the g_j 's (denoted by \mathbb{E}_g) and the η_j 's (denoted by \mathbb{E}_ν) seperately:

$$\begin{aligned} & \mathbb{P}(\sup_{f \in \mathcal{F}} |\mathbb{G}_n^\nu(f) - \mathbb{G}_n^\nu(g_{f, \mu_n})| > \delta) \\ & \leq C \cdot \mathbb{E}_\nu \mathbb{E}_g (\sup_{f \in \mathcal{F}} |n^{-1/2} \sum_{j \leq n} g_j \cdot (f - g_{f, \mu_n})(\eta_j)|) \end{aligned}$$

where the constant C depends on δ but not on n .

Now, for fixed realizations $\eta_1(\omega), \dots, \eta_n(\omega)$ consider the process $\mathbb{Z}_{\nu_n}^\omega = (Z_{\nu_n}^\omega(f))_{f \in \mathcal{F}_n}$ with

$$Z_{\nu_n}^\omega(f) := n^{-1/2} \sum_{j \leq n} g_j \cdot f(\eta_j(\omega)) \quad , f \in \mathcal{F}_n,$$

$$\text{and } \mathcal{F}_n := \{f, g_{f, \mu_n} : f \in \mathcal{F}\}.$$

Then $\mathbb{Z}_{\nu_n}^\omega$ is a mean-zero Gaussian process with

$$\text{cov}(Z_{\nu_n}^\omega(f_1), Z_{\nu_n}^\omega(f_2)) = \nu_n(f_1 \cdot f_2, \omega) \quad \text{for } f_1, f_2 \in \mathcal{F}_n,$$

where $\nu_n(f_1 \cdot f_2, \omega) := n^{-1} \sum_{j \leq n} \delta_{\eta_j(\omega)}(f_1 \cdot f_2)$.

Considering instead the process (indexed also by \mathcal{F}_n)

$$\mathbb{G}_{\nu_n}^\omega + g \cdot \nu_n(\cdot, \omega) = (G_{\nu_n}^\omega(f) + g \cdot \nu_n(f, \omega))_{f \in \mathcal{F}_n},$$

where $\mathbb{G}_{\nu_n}^\omega = (G_{\nu_n}^\omega(f))_{f \in \mathcal{F}_n}$ is a mean-zero Gaussian process with

$$\text{cov}(G_{\nu_n}^\omega(f_1), G_{\nu_n}^\omega(f_2)) = \nu_n(f_1 \cdot f_2, \omega) - \nu_n(f_1, \omega) \cdot \nu_n(f_2, \omega)$$

for $f_1, f_2 \in \mathcal{F}_n$, and where g with $\mathcal{L}\{g\} = \mathcal{N}(0, 1)$ is independent of $\mathbb{G}_{\nu_n}^\omega$, we have (as can be seen by computing covariances) that $\forall \omega$

$$(\star) \quad \mathbb{Z}_{\nu_n}^\omega \stackrel{\mathcal{L}}{\underset{\text{fidi}}{=}} \mathbb{G}_{\nu_n}^\omega + g \cdot \nu_n(\cdot, \omega).$$

Thus $\forall \omega$

$$\begin{aligned} & \mathbb{E}_g \left(\sup_{f \in \mathcal{F}} |n^{-1/2} \sum_{j \leq n} g_j \cdot (f - g_{f, \mu_n})(\eta_j(\omega))| \right) \\ & \stackrel{(\star)}{\leq} \mathbb{E} \left(\sup_{f \in \mathcal{F}} |G_{\nu_n}^\omega(f) - G_{\nu_n}^\omega(g_{f, \mu_n})| \right) + \mathbb{E}(|g|) \cdot \sup_{f \in \mathcal{F}} |\nu_n(f - g_{f, \mu_n}, \omega)| \\ & \leq \sup_{\nu \in \mathcal{M}^1(X)} \mathbb{E} \left(\sup_{f \in \mathcal{F}} |G_\nu(f) - G_\nu(g_{f, \mu_n})| \right) + \mathbb{E}(|g|) \cdot \sup_{\nu \in \mathcal{M}^1(X)} \sup_{f \in \mathcal{F}} |\nu(f - g_{f, \mu_n})|. \end{aligned}$$

Now let $\varepsilon > 0$ be arbitrary and (using (7.5.7)) choose $\delta > 0$ s.t.

$$\sup_{\nu \in \mathcal{M}^1(X)} \mathbb{E} \left(\sup \{ |G_\nu(h_1) - G_\nu(h_2)| : h_1, h_2 \in \mathcal{F} \cup \mathcal{G}, d_\nu^{(2)}(h_1, h_2) \leq \delta \} \right) \leq \varepsilon.$$

Then by (7.5.8) for large enough n we have for all $f \in \mathcal{F}$

$$\begin{aligned} & \sup_{\nu \in \mathcal{M}^1(X)} (d_\nu^{(2)}(f, g_{f, \mu_n}))^2 \\ & = \sup_{\nu \in \mathcal{M}^1(X)} \nu((f - g_{f, \mu_n})^2) = \sup_{\nu \in \mathcal{M}^1(X)} \int_X \left[\int_X (f(x+y) - f(x)) \mu_n(dy) \right]^2 \nu(dx) \leq \delta^2, \end{aligned}$$

and so

$$\begin{aligned} & \limsup_{n \rightarrow \infty} \sup_{\nu \in \mathcal{M}^1(X)} \mathbb{E}_\nu \mathbb{E}_g \left(\sup_{f \in \mathcal{F}} |n^{-1/2} \sum_{j \leq n} g_j \cdot (f - g_{f, \mu_n})(\eta_j)| \right) \\ & \leq \limsup_{n \rightarrow \infty} \sup_{\nu \in \mathcal{M}^1(X)} \mathbb{E} \left(\sup_{f \in \mathcal{F}} |G_\nu(f) - G_\nu(g_{f, \mu_n})| \right) + \mathbb{E}(|g|) \limsup_{n \rightarrow \infty} \sup_{\nu \in \mathcal{M}^1(X)} \sup_{f \in \mathcal{F}} |\nu(f - g_{f, \mu_n})| \\ & = \limsup_{n \rightarrow \infty} \sup_{\nu \in \mathcal{M}^1(X)} \mathbb{E} \left(\sup \{ |G_\nu(f) - G_\nu(g_{f, \mu_n})| : f \in \mathcal{F}, d_\nu^{(2)}(f, g_{f, \mu_n}) \leq \delta \} \right) + 0 \\ & \leq \sup_{\nu \in \mathcal{M}^1(X)} \mathbb{E} \left(\sup \{ |G_\nu(h_1) - G_\nu(h_2)| : h_1, h_2 \in \mathcal{F} \cup \mathcal{G}, d_\nu^{(2)}(h_1, h_2) \leq \delta \} \right) \leq \varepsilon, \end{aligned}$$

where we have used that

$$\begin{aligned} & \limsup_{n \rightarrow \infty} \sup_{\nu \in \mathcal{M}^1(X)} \sup_{f \in \mathcal{F}} |\nu(f - g_{f, \mu_n})| \\ & \leq \limsup_{n \rightarrow \infty} \sup_{\nu \in \mathcal{M}^1(X)} \sup_{f \in \mathcal{F}} \left[\int_X \left[\int_X (f(x+y) - f(x)) \mu_n(dy) \right]^2 \nu(dx) \right]^{1/2} = 0 \end{aligned}$$

according to (7.5.8). Thus (a) is proved.

To conclude the proof of (7.5.11) for $i = 1$, we still have to show (see (7.5.13)) that

$$\lim_{\tau \rightarrow 0} \limsup_{n \rightarrow \infty} \sup_{\nu \in \mathcal{M}^1(X)} \mathbb{P}(\sup\{|G_n^\nu(f_1) - G_n^\nu(f_2)| : f_1, f_2 \in \mathcal{F}, d_\nu^{(2)}(f_1, f_2) \leq \tau\} > \delta) = 0$$

for all $\delta > 0$.

This is proved by similar techniques. Since this expression, however, does not involve any smoothing operations we refer to [Gi97] for a proof.

So we have shown (7.5.11) for $i = 1$, too, and the theorem is proved. \square

Finally, from [Va96], Theorem 2.8.3 we have that (7.5.6) and (7.5.7) are fulfilled if $\mathcal{F} \cup \mathcal{G}$ has uniformly integrable L_2 -entropy, which in turn is implied if $\mathcal{F} \cup \mathcal{G}$ is a VCGC. So, Theorem 7.5.5 yields

7.5.14 THEOREM.

Let X be a linear metric space and let \mathcal{F} be uniformly bounded. Suppose that $\mathcal{F} \cup \mathcal{G}$ has uniformly integrable L_2 -entropy and that (7.5.8) is fulfilled. Then

$$\sup_{\nu \in \mathcal{M}^1(X)} d_{BL}(\tilde{\mathbb{G}}_n^\nu, \mathbb{G}_\nu) \rightarrow 0.$$

7.5.15 REMARK.

The results of section 7.5 are important in the area of bootstrapping empirical processes (see e.g. [Gi91], [Gi97], [Ro97], [She92] and [Va96], Section 3.6); concerning smoothed bootstrapped empirical processes we refer to a forthcoming paper by [Ro99a].

List of Symbols

iid	independent identically distributed	1
rv	random variable	1
$\mathcal{L}\{\eta_j\}$	law of η_j	1
$U[0, 1]$	uniform distribution on $[0, 1]$	1
$I = [0, 1]$	unit intervall	1
p-space	probability space	1
edf	empirical distribution function	1
1_A	indicator function	1
CLT	central limit theorem	1
LLN	law of large numbers	1
a.s.	almost sure	1
$\xrightarrow{\mathcal{L}}$	convergence in law	1
\mathbb{Q}	rational numbers	2
α_n	uniform empirical process	2
$D = D(I)$	function space	2
$C = C(I)$	function space	2
ρ	sup-metric	2
s	Skorokhod's metric	2
$\mathcal{B}(\rho)$	Borel σ -field (in (D, ρ))	2
$\mathcal{B}(s)$	Borel σ -field (in (D, s))	2
$\mathcal{B}_b(\rho)$	σ -field (in (D, ρ)) generated by the open ρ -balls	2
π_t	projection	2
$\mathcal{B}(C, \rho)$	Borel σ -field (in (C, ρ))	2
$\mathcal{B}_b(C, \rho)$	σ -field (in (C, ρ)) generated by the open ρ -balls	2
$\sigma(\{\pi_t : t \in I\})$	σ -field generated by the projections	2
$B = (B(t))_{t \in [0,1]}$	Brownian Motion	3
$B^\circ = (B^\circ(t))_{t \in [0,1]}$	Brownian Bridge	3
$t_1 \wedge t_2$	minimum of t_1 and t_2	3
re	random element	3
$C^b(D)$	class of all bounded, s -continuous, real functions on D	3
$C_b^b(D)$	class of all bounded, ρ -continuous, $\mathcal{B}_b(\rho)$ -measurable, real functions on D	3
$\xrightarrow{\mathcal{L}_b}$	convergence in law	3
ζ_n	partial-sum process	4
$\langle a \rangle$	greatest natural number less or equal to a	4
CTL-C	characterization theorem of \mathcal{L} -convergence	5
\mathbb{P}^*	outer probability	5
w_{α_n}	modulus of continuity w.r.t. α_n	5
w.l.o.g.	without loss of generality	5
\mathbb{Z}_+	natural numbers including 0	5
$ T $	cardinality of T	5
p.d.	pairwise disjoint	7

Φ	standard normal distribution function	8
\square	end of proof	8
J_n	$\{1, \dots, n\}^d$	10
ν_n	empirical measure	10
$\delta_{\underline{y}}$	Dirac measure	10
δ_{η_j}	(random) Dirac measure	10
\mathcal{B}^d	Borel σ -field in \mathbb{R}^d	11
$l^\infty(\mathcal{C})$	class of all bounded, real functions on \mathcal{C}	11
$\ \cdot\ _{\mathcal{C}}$	sup-norm on $l^\infty(\mathcal{C})$	11
$\mathcal{C}A$	complement of A	12
$co(A)$	convex hull of A	12
$\mathcal{P}(D)$	power set of D	13
$\mathcal{X}^{\mathbb{N}} \equiv \bigotimes_{\mathbb{N}} \mathcal{X}$	product σ -field	13
$\nu^{\mathbb{N}} \equiv \times_{\mathbb{N}} \nu$	product measure	13
$\Delta^{\mathcal{C}}(F)$	number of subsets of F which are intersected by \mathcal{C}	13
VCC	Vapnik-Chervonenkis class	13
VCGC	Vapnik-Chervonenkis graph class	15
$\ \nu_n - \nu\ _{\mathcal{C}}$	empirical discrepancy	16
w.r.t.	with respect to	16
$\xrightarrow{\mathbb{P}}$	convergence in probability	17
$D_n(\mathcal{C}_0, \nu)$	scan-statistic	18
$\mathbb{G}_\nu = (G_\nu(C))_{C \in \mathcal{C}}$	mean-zero Gaussian process	19
$\beta_n = (\beta_n(C))_{C \in \mathcal{C}}$	empirical \mathcal{C} -process	18
$U^b(\mathcal{C}, d_\nu)$	class of all bounded, uniformly d_ν -continuous, real functions on \mathcal{C}	19
d_ν	pseudo-metric	19
$C^b(S)$	class of all bounded, continuous, real functions on S	20
\mathbb{E}^*	outer expectation	21
\mathbb{E}_*	inner expectation	21
$\xrightarrow[\text{sep}]{\mathcal{L}}$	separable convergence	21
$\xrightarrow[\text{fidi}]{\mathcal{L}}$	fidi convergence	22
$\underline{\underline{\mathcal{L}}}$	equality of the fidis	22
AEC	asymptotic equicontinuity condition	22
$U^b(T, d)$	class of all bounded, uniformly d -continuous, real functions on T	22
∂B	boundary of B	23
S_0^c	closure of S_0	23
C_x^0	interior of C_x	23
$\overline{\mathbb{R}}$	$\mathbb{R} \cup \{+\infty\}$	29
rq	random quantity	29
ζ^*	minimal measurable majorant	29

(w_{nj})	triangular array of p-measures	30
S_n	Random Measure Process	30
$l^\infty(\mathcal{F})$	class of all bounded, real functions on \mathcal{F}	30
$\ \cdot\ _{\mathcal{F}}$	sup-norm on $l^\infty(\mathcal{F})$	30
$K_n(\cdot, \cdot)$	sequential uniform empirical process	31
$G_n(\cdot, \cdot)$	distribution function pertaining to $K_n(s, t)$	32
$N(u, T, d)$	covering number	39
$H(u, T, d)$	metric entropy	39
$D(u, T, d)$	packing number	39
$V(\mathcal{C})$	Vapnik-Chervonenkis Index	40
\mathcal{R}	graph region class	49
$V(\mathcal{R})$	Vapnik-Chervonenkis Index of \mathcal{R}	49
$d_\nu^{(1)}$	metric on \mathcal{F}	50
$d_\nu^{(2)}$	metric on \mathcal{F}	53
$\bar{d}_{\mu_n\delta}^{(1)}$	(random) pseudo-metric on \mathcal{F}	62
$\xrightarrow{L_p}$	convergence w.r.t. the L_p -metric	63
$\tilde{\nu}_n = \nu_n \star \mu_n$	smoothed empirical measure	69
$\tilde{\mathcal{F}}$	the class of all translates	72
$N^{[]}(\tau, \mathcal{F}, \nu)$	covering number with bracketing	74
$\bar{d}_{\tilde{\nu}_n}^{(1)}$	(random) pseudo-metric on \mathcal{F}	75
$BL_1(l^\infty(\mathcal{F}))$	class of all bounded Lipschitz functions on $l^\infty(\mathcal{F})$	80
$d_{BL}(\eta_n, \eta_0)$	distance of η_n and η_0	80
\mathbb{G}_n^ν	empirical process	96
$\mathcal{M}^1(X)$	space of all p-measures on \mathcal{X}	96
$\tilde{\mathbb{G}}_n^\nu$	smoothed (unbiased) empirical process	97
$\mathcal{N}_k(0, \Sigma_k)$	k -dimensional normal distribution	99

References

- [Al84] Alexander, K.S. (1984). Probability inequalities for empirical processes and a law of the iterated logarithm for empirical processes. *Ann Probab.* **12**, 1041 - 1067.
- [Al86] Alexander, K.S. and Pyke, R. (1986). A uniform central limit theorem for set-indexed partial-sum processes with finite variance. *Ann. Probab.* **14**, 582 - 597.
- [Al87] Alexander, K.S. (1987). Central limit theorems for stochastic processes under random entropy conditions. *Probab. Theory Relat. Fields* **75**, 351 - 378.
- [An87] Andersen, N.T. and Dobrič, V. (1987). The central limit theorem for stochastic processes. *Ann. Probab.* **15**, 164 - 177.
- [Ar92] Arcones, M., Gaenssler, P. and Ziegler, K. (1992). Partial-Sum processes with random locations and indexed by Vapnik-Chervonenkis classes of sets in arbitrary sample spaces. In: *Probability in Banach Spaces* **8**, 379 - 389, R.M. Dudley, Marjorie G. Hahn and J. Kuelbs (Eds.), Birkhäuser.
- [Ba85] Bass, R.F. and Pyke, R. (1985). The space $D(\mathcal{A})$ and weak convergence for set-indexed processes. *Ann. Probab.* **13**, 860 - 884.
- [Bi71] Bickel, P.J. and Wichura, M.J. (1971). Convergence criteria for multiparameter stochastic processes and some applications. *Ann. Math. Statist.* **42**, 1656 - 1670.
- [Bi68] Billingsley P. (1968). *Convergence of Probability Measures*. Wiley.
- [Ca33] Cantelli, F.P. (1933). Sulla determinazione empirica leggi di probabilità. *Giorn. Ist. Ital Attuari* **4**, 421 - 424.
- [Che56] Chentsov, N.N. (1956). Lévy Brownian motion for several parameters and white noise. *Theor. Prob. Appl.* **2**, 265 - 266.
- [De71] Dehardt, J. (1971). Generalizations of the Glivenko-Cantelli theorem. *Ann. Math. Statist.* **42**, 2050 - 2055.
- [Dev85] Devroye, L. and Györfi, L. (1985). *Nonparametric density estimation. The L_1 view*. Wiley.
- [Do49] Doob, J.L. (1949). Heuristic approach to the Kolmogorov-Smirnov theorems. *Ann. Math. Statist.* **20**, 393 - 403.
- [Don51] Donsker, M.D. (1951). An invariance principle for certain probability limit theorems. *Mem. Amer. Math. Soc.* **6**, 1 - 12.
- [Don52] Donsker, M.D. (1952). Justification and extension of Doob's heuristic approach to the Kolmogorov-Smirnov theorems. *Ann. Math. Statist.* **23**, 277 - 281.
- [Du66] Dudley, R.M. (1966). Weak convergence of probabilities on nonseparable metric spaces and empirical measures on Euclidian spaces. III. *J. Math.* **10**, 109 - 126.
- [Du78] Dudley, R.M. (1978). Central limit theorems for empirical measures. *Ann. Probab.* **6**, 899 - 929; Correction: *Ann. Probab.* **7**, 909 - 911.
- [Du83] Dudley, R.M. and Philipp, W. (1983). Invariance principles for sums of Banach space valued random elements and empirical processes. *Z. Wahrsch. verw. Gebiete* **62**, 509 - 552.

- [Du84] Dudley, R.M. (1984). A course on empirical processes. Springer Lecture Notes in Math. **1097**, 1 - 142.
- [Du92] Dudley, R.M. (1992). Uniform Central Limit Theorems. Manuscript, MIT.
- [Du99] Dudley, R.M. (1999). Uniform Central Limit Theorems. Cambridge University Press.
- [Dur80] Durst, M. and Dudley, R.M. (1980). Empirical Processes, Vapnik-Chervonenkis classes and Poisson Processes. Prob. and Math. Statist. (Wroclaw) **1**, Fasc. 2, 109 - 115.
- [Ei97] Einmahl, U. and Mason, D. (1997). Gaussian approximation of local empirical processes indexed by functions. Probab. Thoery Relat. Fields **107**, 283 - 311.
- [Ei98] Einmahl, U. and Mason, D. (1998). An Empirical Process Approach to the Uniform Consistency of Kernel-Type Function Estimators. Preprint.
- [El79] Elker, J., Pollard, D. and Stute, W. (1979). Glivenko-Cantelli theorems for classes of convex sets. Adv. Appl. Probab. **11**, 820 - 833.
- [Fe91] Fernholz, L.T. (1991). Almost sure convergence of smoothed empirical distribution functions. Scand. J. Statist. **18**, 255 - 262.
- [Gae77] Gaenssler, P. and Stute, W. (1977). Wahrscheinlichkeitstheorie. Springer Hochschultext.
- [Gae79] Gaenssler, P. and Stute, W. (1979). Empirical Processes: A survey of results for independent and identically distributed random variables. Ann. Probab. **7**, 193 - 243.
- [Gae83] Gaenssler, P. (1983). Empirical Processes. IMS Lecture Notes - Monograph Series, Vol 3, Hayward.
- [Gae87] Gaenssler, P. (1987). On a modification of the k -means clustering procedure. Proc. Fifth Int. Symp. on Data Analysis and Informatics, E. Diday (Ed.), 365 - 371. North Holland.
- [Gae90] Gaenssler, P. and Schneemeier, W. (1990). On Functional Limit theorems for a Class of Stochastic Processes Indexed by Pseudo-Metric Parameter Spaces. In: Probability in Banach Spaces, **9**. U. Haagerup, J. Hoffmann-Jørgensen N.J. Nielsen (Eds.). Progress in Probability **20**, pp. 82 - 100, Birkhäuser.
- [Gae92] Gaenssler, P. (1992). On weak convergence of certain processes indexed by pseudo-metric parameter spaces with applications to empirical processes. Transactions of the 11 th. Prague conference, pp. 49 - 78, Academia.
- [Gae94] Gaenssler, P. (1994). On recent developments in the theory of set-indexed processes. In: Asymptotic Statistics. P. Mandl and M. Hušková (Eds.), pp. 87 - 109. Physica-Verlag.
- [Gae94b] Gaenssler, P. and Ziegler, K. (1994). A uniform law of large numbers for set-indexed processes with applications to empirical and partial-sum processes. In: Probability in Banach Spaces, **9**, 385 - 400. J. Hoffmann-Jørgensen, J. Kuelbs and M.B. Marcus (Eds.), Birkhäuser.
- [Gae98] Gaenssler, P., Rost, D. and Ziegler, K. (1998). On Random Measure Processes with Application to Smoothed Empirical Processes. In: High Dimensional Probability 1, 93-102. Progress in Probability, Vol. **43**, E. Eberlein, M. Hahn and M. Talagrand, (Eds.), Birkhäuser.
- [Gae99] Gaenssler, P. and Rost, D. (1999). On uniform laws of large numbers for smoothed empirical measures. Preprint, Univ. of Munich.
- [Gi86] Giné, E. and Zinn, J. (1986). Lectures on the Central Limit Theorem for Empirical processes. Springer Lecture Notes in Math. **1221**, 50 - 113.

- [Gi91] Giné, E. and Zinn, J. (1991). Gaussian characterization of uniform Donsker classes of functions. *Ann. Probab.* **19**, 758 - 782.
- [Gi96] Giné, E. (1996). Empirical processes and applications: An overview. *Bernoulli* **2** (1), 1 - 28.
- [Gi97] Giné, E. (1997). Lectures on some aspects of the bootstrap. *École d'Été de Calcul de Probabilités de Saint-Flour XXVI - 1996*. In: Giné, Grimmet and Saloff-Coste: *Lectures on Probability Theory and Statistics*. Springer Lecture Notes in Math. **1665**.
- [Gi91] Giné, E. and Zinn, J. (1991). Gaussian characterization of uniform Donsker classes of functions. *Ann. of Probab.* **19**, 758 - 782.
- [Gl33] Glivenko, V. (1933). Sulla determinazione empirica della legge di probabilità. *Giorn. Ist. Ital Attuari* **4**, 92 - 99.
- [Gro92] Groeneboom, P. and Wellner, J.A. (1992). Information bounds and nonparametric maximum likelihood estimation. *Birkhäuser, DMV Seminar Band 19*.
- [Ho74] Hoffmann-Jørgensen, J. (1974). Sums of independent Banach space valued random variables. *Studia Math.* **52**, 159 - 189.
- [Ho84] Hoffmann-Jørgensen, J. (1984). *Stochastic Processes on Polish Spaces*. Unpublished manuscript.
- [Ho85] Hoffmann-Jørgensen, J. (1985). Necessary and sufficient conditions for the uniform law of large numbers. *Springer Lecture Notes in Math.* **1153**, 258 - 272.
- [Ho91] Hoffmann-Jørgensen, J. (1991). *Stochastic Processes on Polish Spaces*. Various Publication Series Vol. 39, Aarhus Universitet.
- [Ke61] Kelley, J.L. (1961). *General Topology*. van Nostrand.
- [Ki90] Kim, J. and Pollard, D. (1990). Cube root asymptotics. *Ann. Statist.* **18**, 191 - 219.
- [La92] Laskowski, M.C. (1992). Vapnik-Chervonenkis classes of definable sets. *J. London Math. Soc. II, Ser.* **45**, No 2, 377 - 384.
- [Le91] Ledoux, M. and Talagrand, M. (1991). *Probability in Banach spaces*. Springer.
- [Lé40] Lévy, P. (1940). Le mouvement Brownien plan. *Amer. J. Math.* **62**, 487 - 550.
- [Lé45] Lévy, P. (1945). Sur le mouvement brownien dépendant de plusieurs paramètres. *C.R. Acad. Sci. Paris* **220**, 420 - 422.
- [Li90] Liese, F. (1990). Estimation of Intensity Measures of Poisson Point Processes. In: *Transactions 11 th. Prague Conf., Vol. A*, pp. 121 - 139. Kluwer.
- [Ma84] Mack, Y.P.C. (1984). Remarks on some smoothed empirical distribution functions and processes. *Bull. of Informatics and Cybernetics* **21**, 29 - 35.
- [Ne71] Neuhaus, G. (1971). On weak convergence of stochastic processes with multidimensional time parameter. *Ann. Math. Statist.* **42**, 1285 - 1295.
- [No89] Nolan, D. and Marron, J.S. (1989). Uniform consistency of automatic and location-adaptive delta-sequence estimators. *Probab. Theory Relat. Fields* **80**, 619 - 632.
- [Os84] Ossiander, M. (1984). *Weak convergence and the law of the iterated logarithm of partial-sum processes indexed by points in a metric space*. University of Washington Ph.D. Dissertation.

- [Os85] Ossiander, M. and Pyke, R. (1985). Lévy's Brownian motion as a set-indexed process and a related central limit theorem. *Stoch. Proc. and Their Appl.* **21**, 133 - 145.
- [Pf94] Pfanzagl, J. (1994). *Parametric Statistical Theory*. de Gruyter Textbook.
- [Pi83] Pisier, G. (1983). Some applications of the metric entropy condition to harmonic analysis. *Banach spaces, Harmonic Analysis, and Probability Theory*. Springer Lecture Notes in Math. **995**, 123 - 154.
- [Po81] Pollard, D. (1981). Limit theorems for empirical processes. *Z. Wahrsch. verw. Gebiete* **57**, 181 - 195.
- [Po82a] Pollard, D. (1982). Quantization and the method of k -means. *IEEE Trans. Information Theory*, Vol. IT-**28**, No 2, 199 - 205.
- [Po82b] Pollard, D. (1982). A central limit theorem for k -means clustering. *Ann. Probab.* **10**, 919 - 926.
- [Po84] Pollard, D. (1984). *Convergence of Stochastic Processes*. Springer.
- [Po90] Pollard, D. (1990). *Empirical Processes: Theory and Applications* NSF-CBMS Regional Conference Series in Probability and Statistics, Vol 2, Hayward, CA: Institute of Mathematical Statistics.
- [Pra81] Prakasa Rao, B.L.S. (1981). Convergence of smoothed empirical processes for independent random variables. *Aligarh J. of Statist.* **1**, 13 - 18.
- [Pro56] Prohorov, Yu V. (1956). Convergence of random processes and limit theorems in probability theory. *Theor. Probab. Appl.* **1**, 157 - 214.
- [Py72] Pyke, R. (1972). *Empirical Processes*. Jeffrey-Williams Lectures 1968 - 1972, Canadian Mathematical Congress, Montreal (1972), 13 - 43.
- [Py73] Pyke, R. (1973). Partial sums of matrix arrays and Brownian sheets. In: D.G. Kendall and E.F. Harding, Eds., *Stochastic Analysis*, pp. 331 - 448. Wiley.
- [Py84] Pyke, R. (1984). Asymptotic results for empirical and partial-sum processes: A review. *The Canadian Journal of Statistics* **12**, No. 4, 241 - 264.
- [Py88] Pyke, R. and Wilbour, D.C. (1988). New approaches for goodness-of-fit tests for multidimensional data. In: *Statistical Theory and data Analysis II*, pp. 139 - 154. Elsevier Science Publishers (North Holland).
- [Ra62] Ranga Rao, R.R. (1962). Relations between weak and uniform convergence of measures with applications. *Ann. Math. Statist.* **33**, 659 - 680.
- [Re70] Rényi, A. (1970). *Probability Theory*. North Holland.
- [Ro91] Rost, D. (1991). *Das k -mean Clusterverfahren mit Gewichtsfunktion*. Dissertation. Univ. of Munich.
- [Ro95] Rost, D. (1995). A Simulation Study of the Weighted k -means Cluster Procedure. *J. Statist. Computation and Simulation* **53**, 51 - 63.
- [Ro97] Rost, D. (1997). *Approximation results for smoothed empirical processes: A new approach*. Habilitationsschrift, Ludwig-Maximilians-Universität München.
- [Ro99] Rost, D. (1999). *Limit theorems for Smoothed Empirical Processes*. Preprint.
- [Ro99a] Rost, D. (1999). *A consistency theorem for smoothed bootstrapped empirical processes*, Preprint.

- [She92] Sheehy, A. and Wellner, J.A. (1992). Uniform Donsker classes of functions. *Ann. of Probab.* **20**, 1983 - 2030.
- [Sh86] Shorack, G.R. and Wellner, J.A. (1986). *Empirical Processes with Applications to Statistics*. Wiley.
- [St90] Strobl, F. (1990). Zur Verteilungskonvergenz von Zufallsgrößen. Schriftliche Hausarbeit. Universität München.
- [St94] Strobl, F. (1994). Zur Theorie empirischer Prozesse unter besonderer Berücksichtigung des Bootstrap-Verfahrens und Fréchet-differenzierbarer statistischer Funktionale. Dissertation, Univ. of Munich.
- [St95] Strobl, F. (1995). On the reversed sub-martingale property of empirical discrepancies in arbitrary sample spaces. *J. Theoret. Probab.* **8**, 825 - 831.
- [Ste78] Steele, M. (1978). Empirical discrepancies and subadditive processes. *Ann. Probab.* **6**, 118 - 127.
- [Sten89] Stengle, G. and Yukich, J.E. (1989). Some New Vapnik-Chervonenkis classes. *Ann. Statist.* **17**, 1441 - 1446.
- [Str71] Straf, M.L. (1971). Weak convergence of stochastic processes with several parameters. *Proc. Sixth Berkeley Symp. Math. Statist. Prob.* **2**, 187 - 221. Univ. of California Press.
- [Stu86a] Stute, W. (1986). Conditional empirical processes. *Ann. Statist.* **14**, 638 - 647.
- [Stu86b] Stute, W. (1986). On almost sure behavior of conditional empirical distribution functions. *Ann. Probab.* **14**, 891 - 901.
- [Stu97] Stute, W. (1997). Nonparametric model checks for regression. *Ann. Statist.* **25**, 613 - 641.
- [Stu98] Stute, W., Thies, S. and Li-Xiang Zhu (1998). Model checks for regression: An innovation process approach. *Ann. Statist.* **26**, 1916 - 1934.
- [Ta96] Talagrand, M (1996). The Glivenko-Cantelli Problem, Ten years later. *J. of Theoret. Probab.* **9**, 371 - 384.
- [Va94] van der Vaart, A.W. (1994). Weak convergence of smoothed empirical processes. *Scand. J. Statist.* **21**, 501-504.
- [Va96] van der Vaart, A.W. and Wellner, J.A. (1996). *Weak convergence and empirical processes*. Springer Series in Statistics.
- [Val64] Valentine, F. (1964). *Convex Sets*. McGraw Hill.
- [Vap71] Vapnik, V.N. and Chervonenkis, A.Y. (1971). On uniform convergence of the frequencies of events to their probabilities. *Theor. Probab.* **16**, 264 - 280.
- [We92] Wellner, J.A. (1992). *Empirical Processes in Action*. *Internat. Statist. Review* **60**, 247 - 269.
- [Wen81] Wenocur, R.S. and Dudley, R.M. (1981). Some special Vapnik-Chervonenkis classes. *Discrete Math.* **33**, 313 - 318.
- [Wi68] Wichura, M.J. (1968). On the weak convergence of non-Borel probabilities on a metric space. Ph.D. dissertation, Columbia University.
- [Win73] Winter, B.B. (1973). Strong uniform consistency of integrals of density estimators. *Canadian J. of Statist.* **1**, 247-253.

- [Wo60] Wolfowitz, J. (1960). Convergence of the empiric distribution function on half spaces. In: Contributions to Probability and Statistics: Essays in Honor of Harold Hotelling. Stanford Univ. Press.
- [Ya73] Yamato, H. (1973). Uniform convergence of an estimator of a distribution function. Bull. Math. Statist. **15**, 69-78.
- [Yu89] Yukich, J.E. (1989). A note on limit theorems for perturbed empirical processes. Stoch. Proc. and Their Applications. **33**, 163-173.
- [Yu92] Yukich, J.E. (1992). Weak convergence of smoothed empirical processes. Scand. J. Statist. **19**, 271-279.
- [Zi94] Ziegler, K. (1994). On Functional Central Limit Theorems and Uniform Laws of Large Numbers for Sums of Independent Processes. Dissertation, Univ. of Munich.
- [Zi97] Ziegler, K. (1997). Functional Central Limit Theorems for Triangular Arrays of Function-indexed Processes under Uniformly Integrable Entropy Conditions. J. of Multivariate Analysis **62**, 233 - 272.